



SINCE 1909  
JAPAN



KDK Ventilation Fans & Air Moving Equipment



# Ventilation Fans & Air Moving Equipment

Refined Air Quality Solutions



**KDK Company, Division of PES**  
4017, Takaki-cho, Kasugai, Aichi, Japan  
<http://kdk.jp>

• Actual colors may vary slightly from those shown.  
• Specifications are subject to change without prior notice.







CATALOG NO: K-AMCA011  
December 2024

Page	Content
002	About KDK
003	Market Map
004	Product Certification
005	2024 Product Highlight
007	About Indoor Air Quality
009	Installation Simulation
011	Product Summary
021	Ceiling Mount Type Ventilation Fan
035	Wall Mount Type Ventilation Fan
047	Window Mount Type Ventilation Fan
055	Industrial Type Ventilation Fan
063	Cabinet Fan (In-line Fan)
071	Mini Sirocco Fan
079	Energy Recovery Ventilator
089	Thermo Ventilator
093	Range Hood
097	Hand Dryer
101	Air Curtain
109	Ceiling Fan / Electric Fan
121	Ventilation Product Specification Summary
131	Performance Data Summary
155	Project Reference
158	Installation Method

KDK was founded in 1909, with more than a century old history. By making a commitment to our business philosophy, we strive toward contributing to society through our air and wind technologies.

With the aims of offering the premium product and solution through good distributions and services, we will continue to maintain a leading position in the industry by utilizing advantages of our core competencies. With innovative technology and value-added approach, we are committed to make a reliable and quality product with excellent design and high safety standard in meeting the expectations of our customers all over the world.

## Milestone

	— 1909	• KDK (Kawakita Denki Kigyousha) was founded
	— 1913	• Mass production of Typhoon Type Electric Fan
	— 1918	• Registration of KDK Trademark • Starting of export business
	1919	• Kawakita Denki Co. was established in Shanghai
	1933	• Chuou Denki Co., Ltd. was established in Osaka
	1956	• Osaka Denki Seiki Co., Ltd was established
	— 1960	• Registration of new KDK Trademark
	1962	• Renamed the company to Matsushita Seiko Co., Ltd
	1981	• Set up International Fan Manufacturing Co., Ltd [IFCO] in Hong Kong
	1989	• IFCO was renamed as Matsushita Seiko Hong Kong International Manufacturing co., Ltd [HIMCO]
	1993	• Set up Shunde Matsushita Seiko Co., Ltd [SHUMCO] in China. It was renamed as Guangdong Matsushita Seiko Co., Ltd. [GDMESC] in 2003 and further changed to PESGD in 2006
	1995	• Established Beijing Great Wall Matsushita Seiko Air Conditioning Equipment Co., Ltd. [BGMAC] which was renamed as PESGD-BJ in 2005
	1999	• Established Oversea Marketing Headquarter in HIMCO
	2003	• Matsushita Seiko Co. Ltd. was renamed as Matsushita Ecology Systems Co., Ltd. and further changed to KDK Company, Division of PES in 2008
	— 2009	• The 100th Anniversary of KDK
	2016	• Further expanded a brand-new product line of water pump for better living environment
	— 2019	• <b>The 110th Anniversary of KDK</b>
	2021	• PEWVN (Panasonic Electric Works Vietnam Co. Ltd.) was set up in Vietnam
	— 2024	• The 115th Anniversary of KDK

# Market Map

For a century, KDK has established its business in various countries, building its reputation and brand value in the minds of its customers. Moving forward, in addition to continuous development in existing markets, we will explore new business in potential markets throughout other fast-growing regions.

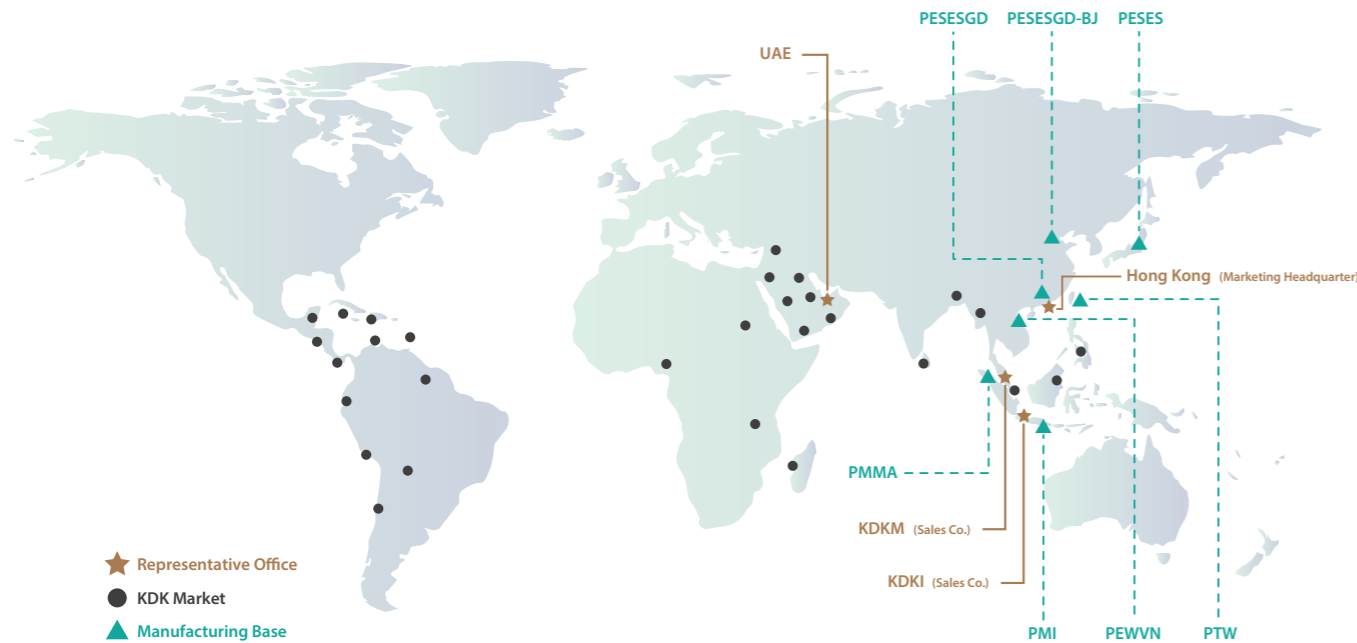

# Distributor List

Country	Distributor
Iraq	Al Khait Alabydh Co
Jordan	Mohammad M Juma & Sons Co.
Kuwait	Salem M. Al-Nisf Electrical Co. W.L.L.
Oman	Mohsin Haider Darwish L.L.C.
Qatar	United Cooperation General Trading L.L.C.
Saudi Arabia	Abdulaziz & Sulaiman Saleh Al-Hakbany Sons Trading Co Haitham Est. for Trading
United Arab Emirates	Electra Abu Dhabi L.L.C. Electra Dubai
Yemen	Al Haj Mohamed Ali Sowaid & Sons
Nigeria	Polysonic Nigeria Ltd.
Sudan	Central Advanced Digitech Co.
Tanzania	Multi Cable Ltd.

# Product Certification

To ensure safety, KDK products are designed and manufactured according to either the standards of JIS (Japan Industrial Standard) or IEC (International Electrotechnical Commission). Test certificates are awarded by recognized test laboratories that further prove the reliability of our products.



## CB Test Certificate

CB Test Certificate is issued to products in compliance with the applicable requirement of IEC standard under CB Scheme (Certification Bodies' Scheme) set by IEC .

Beside the international standard of JIS and IEC, different safety certifications are also acquired to fulfill the requirement in different countries.

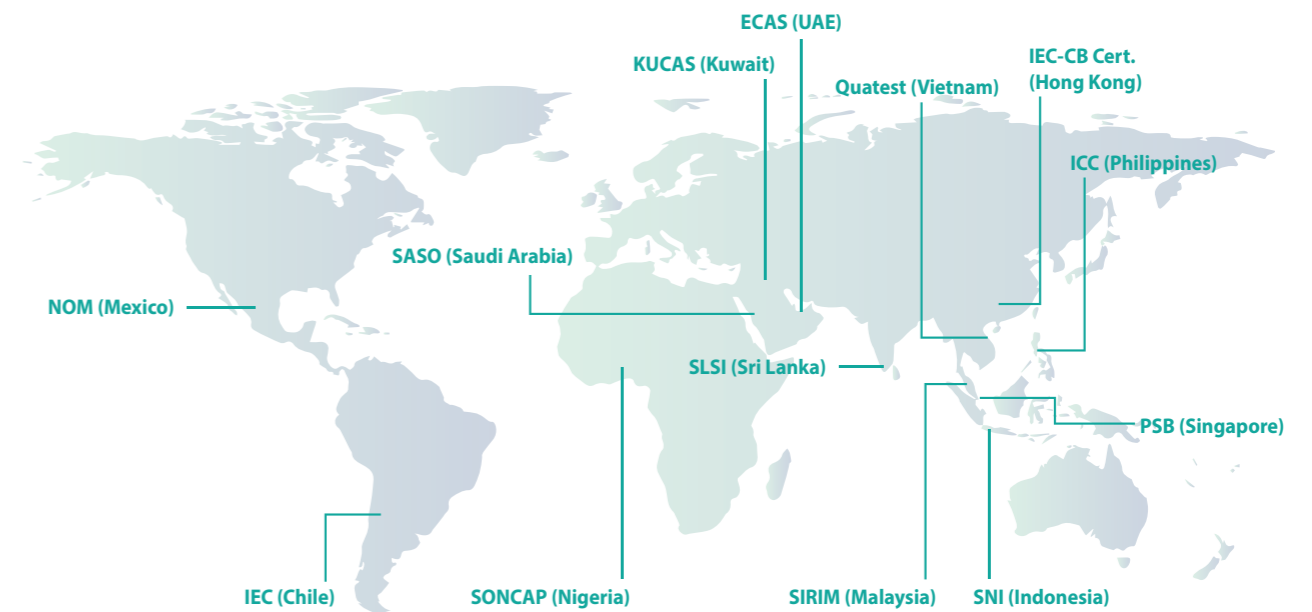

## Certification Acquired

Furthermore, the performance of Panasonic products are qualified by external authority.

### AMCA Mark, USA

AMCA (Air Movement And Control Association International. Inc.) of The United States for ventilation products

# 2024 Product Highlight

## KDK Ventilation Fans

Empowering Every Moment Around the Clock.  
Bringing 24-Hour Comfort, 365 Days of Fresh Air Excellence.



Reduce CO<sub>2</sub> Emission



Alleviate Global Warming



Reduce Electric Bill Expenditure

Constant Performance by Intelligent Technology



Fan is able to perform at constant airflow regardless of elbows in pipe.

Fan speed automatically increased to ensure the desired airflow.

Fan is able to perform as rated.



DC Motor



Energy Saving



Fresh Air

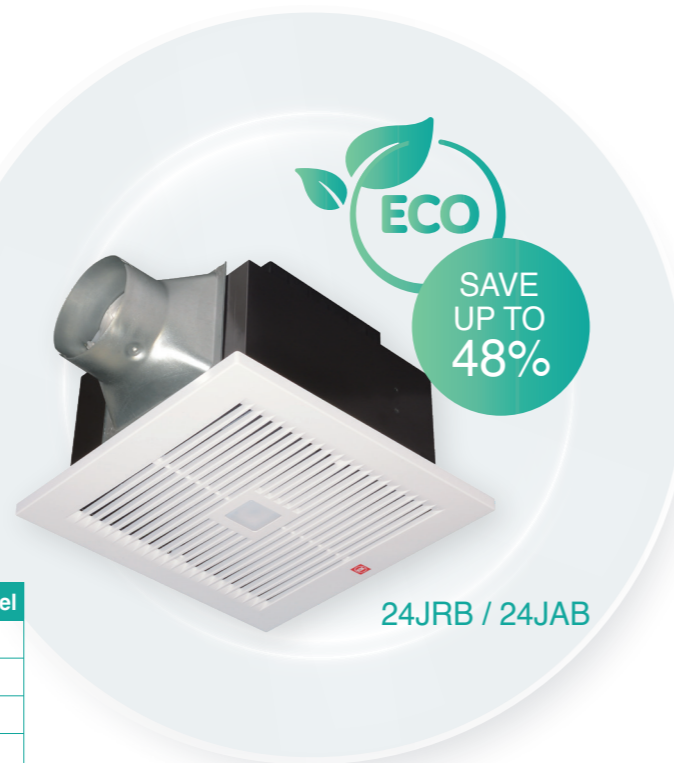

24JRB / 24JAB

Motor Type	DC Motor Model	AC Motor Model
Model	24JRB	24CUH
Static Pressure [Pa]	0	0
Air Volume [m <sup>3</sup> /h]	160	140
Power Consumption at 0 Pa [W]	7	13.5
Energy Efficiency [m <sup>3</sup> /h / Watt]	22.9	10.3

Power consumption comparison between DC motor series and non-DC motor series

Note: Values measured at 220V 60Hz.

## High Air Volume Ceiling Mount Type Ventilation Fan

Our Product was Developed to Overcome...



Highly Bending Ventilation Ducts



Noisy Operation Sound



Insufficient Air Exhaust



24CXH

Powerful Exhaustion

Air volume up to **255 CMH**

\*Values measured at 220V 60Hz

## KDK Thermo Ventilator

Embrace warmth, shielded from cold shocks, for cozy comfort every chilly day.



30BUC



Ventilation



Circulation



Heating



Clothes Drying



Reduce temperature difference between bathroom and corridor.

Reduce the risk of getting heat shock response.



# IAQ

Air Supply  
Air Exhaust  
Air Circulation 3 core KDK solutions to enhance indoor air quality

INDOOR AIR QUALITY

## The Importance of Indoor Air Quality

We care about the food we eat and the water that we drink, but what about AIR?  
It is important to take care of the ONE thing we consume the most...

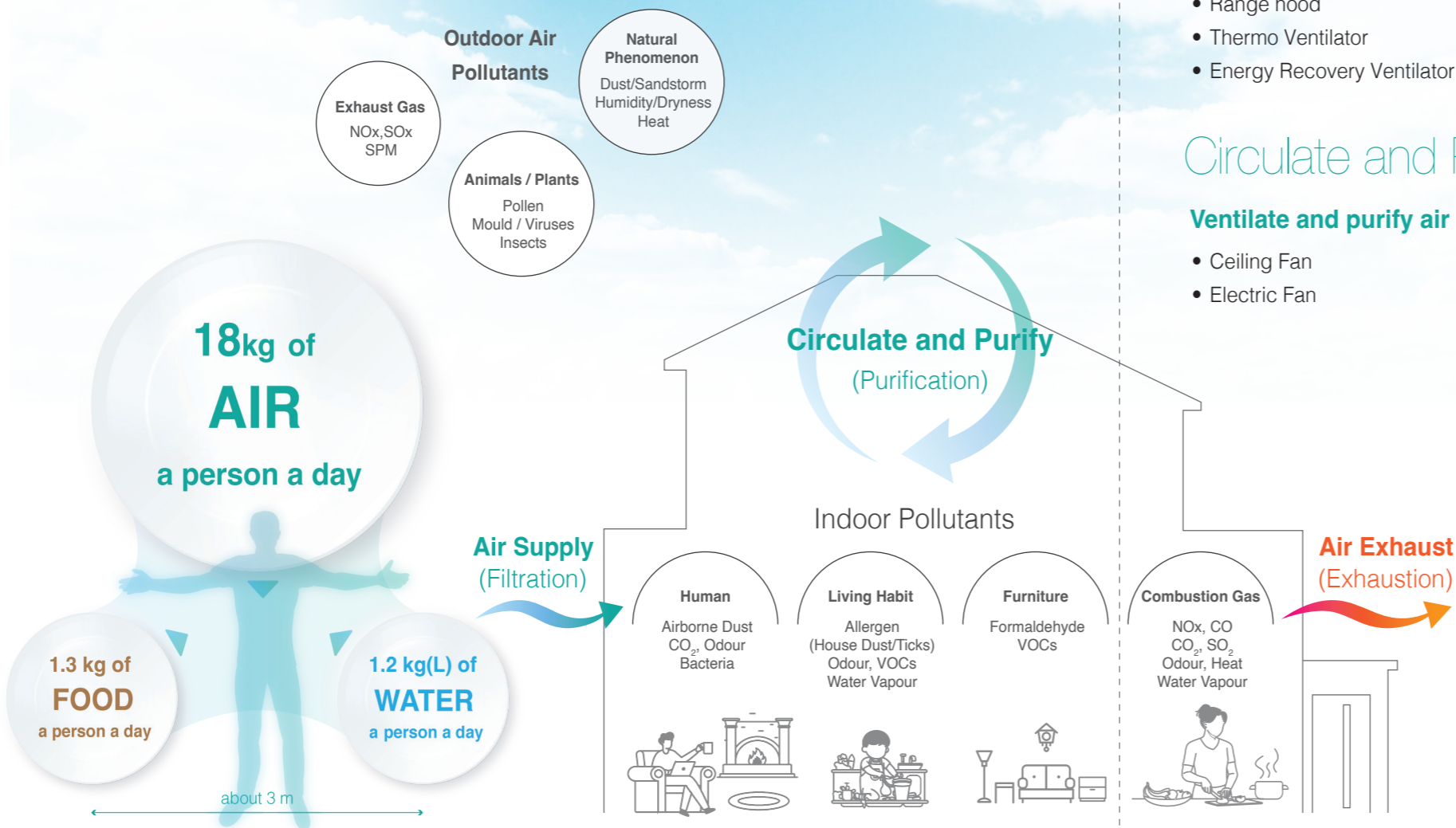

## Ventilation

### Air Supply

Prevent entrance of unwanted substances

- Energy Recovery Ventilator
- Ventilation Fan (reversible type)

### Air Exhaust

Reduce unwanted substances indoor

- Ventilation Fan
- Range hood
- Thermo Ventilator
- Energy Recovery Ventilator

## Circulate and Purify

### Ventilate and purify air

- Ceiling Fan
- Electric Fan

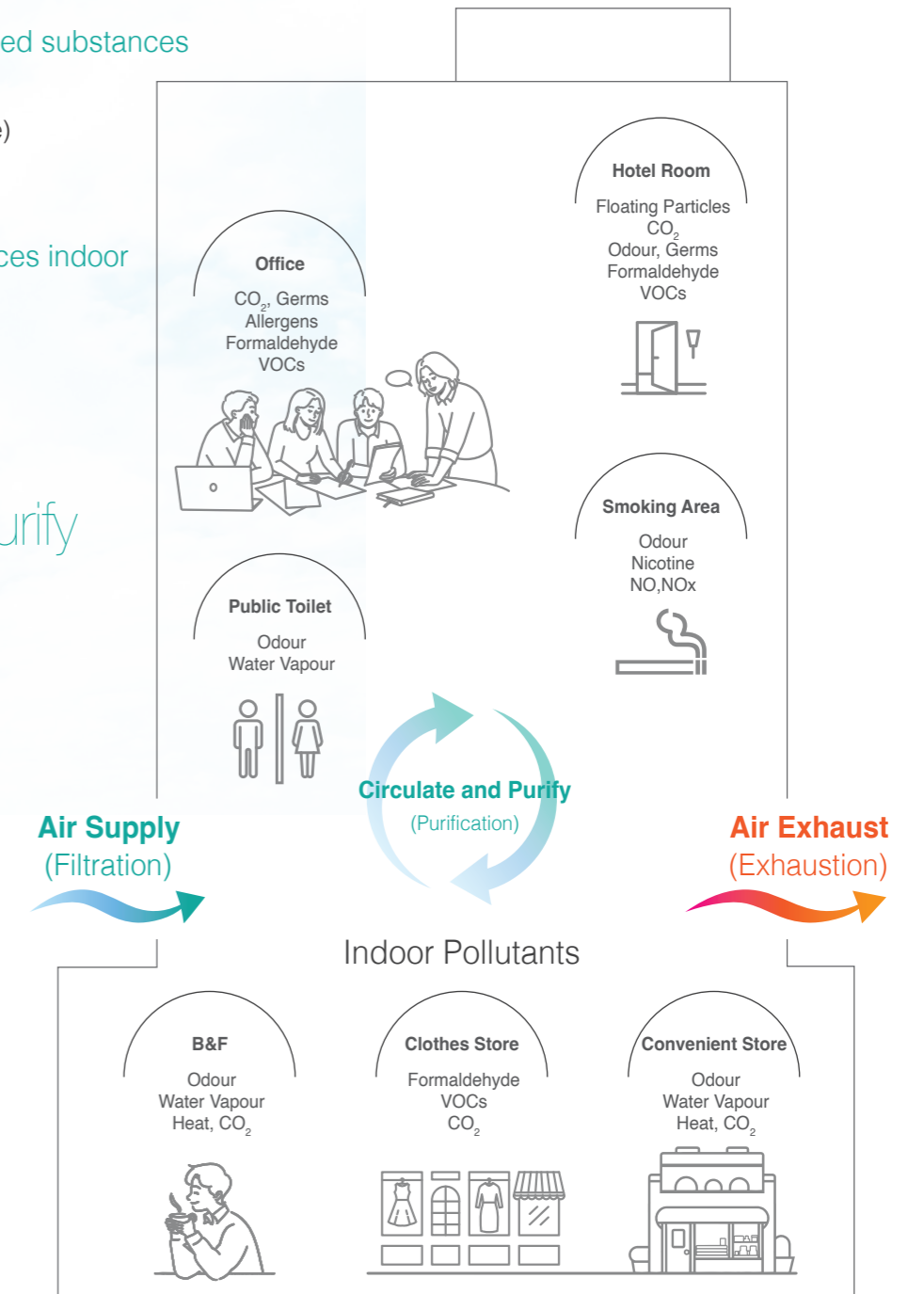

\*1 "Air and Humans – From a Physiological Viewpoint" (1999) by UCHIYAMA Iwao (National Institute of Public Health of Japan)









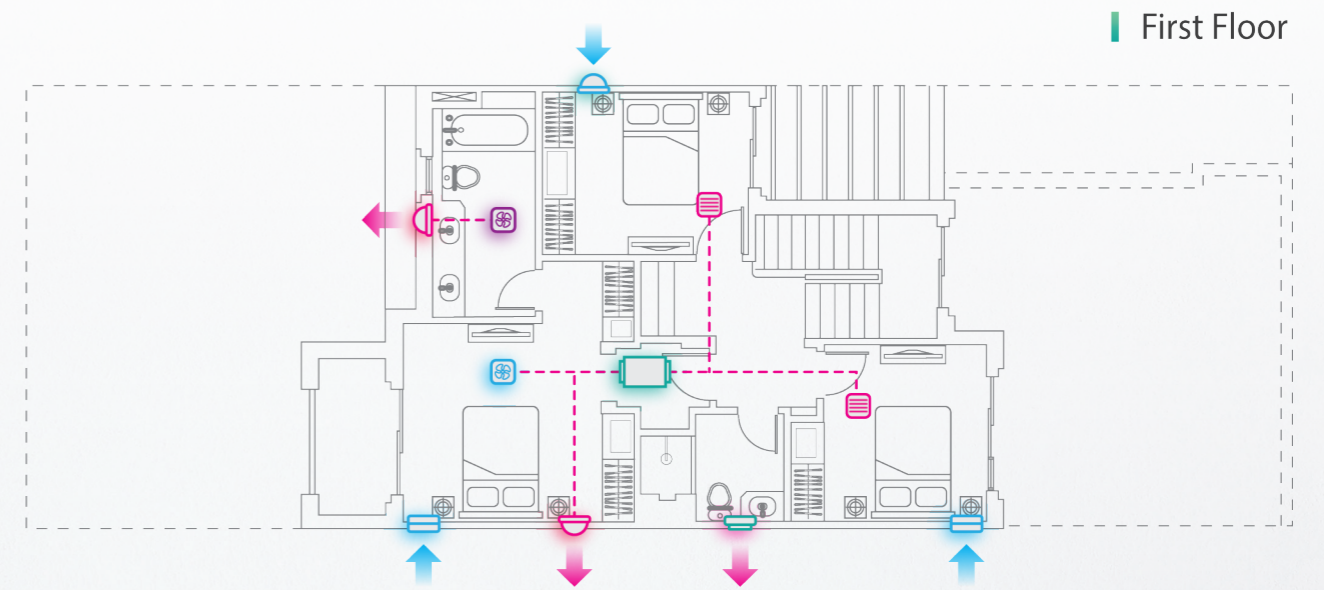
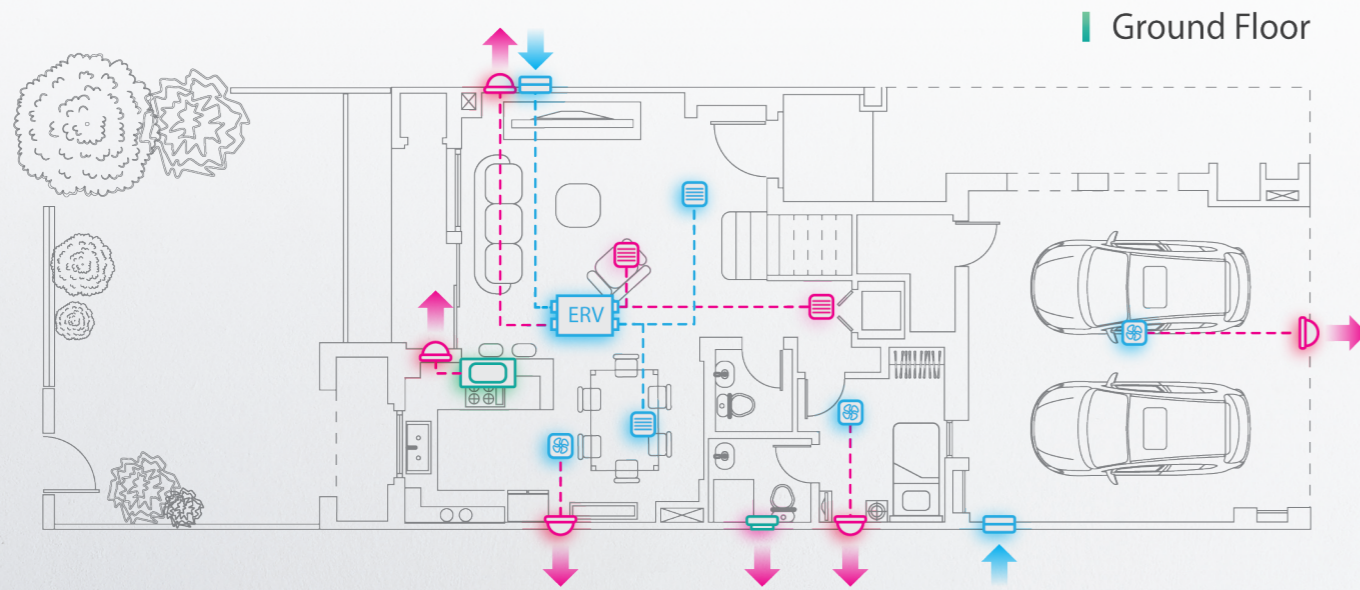

\*2 "Heat Stroke Environmental Health Manual (2009)" from the Ministry of the Environment, Government of Japan

\*3 "Basic Data Sheet of Agriculture, Forestry, and Fisheries, Statistics Regarding The Food Self-Sufficiency Rate" from Ministry of Agriculture, Forestry and Fisheries of Japan

# Refining Your Indoor Environment

## Installation Simulation (2-story villa as example)



-  Ceiling Mount Type Ventilation Fan
-  Wall Mount Type Ventilation Fan
-  Cabinet Fan (In-line Fan)
-  Energy Recovery Ventilator
-  Thermo Ventilator
-  Range Hood
-  Intake Grille
-  Exhaust Grille
-  Vent Cap / Pipe Hood
-  Intake
-  Exhaust

# Product Summary

Product	Series	Model	DC Motor	Super Low Noise Level	Fire Resistant	Voltage/Frequency	Air Volume [CFM]	Consumption [W]	RPM	Page	
Ceiling Mount Type Ventilation Fan	DC Motor Series		24JRB	✓	-	-	220V/60Hz	88	10	853	023
							240V/50Hz	88	10	853	
			24JAB	✓	-	-	220V/60Hz	88	10	839	024
							240V/50Hz	88	10	839	
	Super Quiet Series		17CUH	-	✓	-	220V/60Hz	44	10	664	025
							240V/50Hz	51	10	728	
			24CUH	-	✓	-	220V/60Hz	83	13	585	026
							240V/50Hz	89	13	614	
			24CDH	-	✓	-	240V/50Hz	106	17	782	
			24CHH	-	✓	-	220V/60Hz	109	22	791	
			24CXH	-	✓	-	220V/60Hz	109	22	791	027
							240V/50Hz	117	21	861	
			24CXH	-	✓	-	220V/50Hz	138	24	890	
							220V/60Hz	150	29	950	
							230V/50Hz	141	26.5	910	
			240V/50Hz	-	✓	-	240V/50Hz	147	29	940	
		220V/60Hz					182	33	570		
			27CHH	-	✓	-	220V/60Hz	182	33	570	028
							240V/50Hz	198	37	609	
			32CDH	-	✓	-	220V/60Hz	226	48	580	029
							240V/50Hz	257	56	675	
		Standard Series		38CDG/	-	-	-	220V/60Hz	344	98	626
	240V/50Hz							387	737		
	38CDG 05			-	-	-	240V/50Hz	387	118	737	
			38CHG	-	-	-	220V/50H (Hi)	471	122	790	031
							220V/50H (Lo)	309	89	540	
							220V/60Hz (Hi)	465	138	760	
							220V/60Hz (Lo)	294	90	509	
							230V/50Hz (Hi)	471	122	775	
							230V/50Hz (Lo)	277	84	485	
240V/50Hz (Hi)							491	132	807		
240V/50Hz (Lo)	288	90	50								
Metal Series		24CMUA	-	-	✓	220V/60Hz	55	13	495	032	
						240V/50Hz	55	14	562		
		24CMHA	-	-	✓	220V/60Hz	94	25	681	033	
						240V/50Hz	108	27	753		
		27CMHA	-	-	✓	220V/60Hz	208	46	615		
						240V/50Hz	240	46	669		





Product	Series	Model	Silent Stream Fan	Auto Shutter	Louver	Voltage/Frequency	Air Volume [CFM]	Consumption [W]	RPM	Page					
Wall Mount Type Ventilation Fan	Metallic Series		20ASB	-	✓	-	220V/60Hz	330	25.5	1,358	037				
							240V/50Hz	296	22.4	1,252					
		20ASB 05	-	✓	-	240V/50Hz	296	22.4	1,252						
						220V/60Hz	522	35.5	1,277						
		25ASB	-	✓	-	240V/50Hz	486	35.1	1,194						
						220V/60Hz	522	35.5	1,277						
		25ASB 05	-	✓	-	240V/50Hz	486	35.1	1,194						
						220V/60Hz	637	39.8	1,088						
		30ASB	-	✓	-	240V/50Hz	706	38.1	1,175						
						220V/60Hz	637	39.8	1,088						
	30ASB 05	-	✓	-	240V/50Hz	706	38.1	1,175							
					220V/60Hz	637	39.8	1,088							
	Automatic Shutter Series		15AAQA	-	✓	-	220V/60Hz	157	20.6	1,533	038				
							240V/50Hz	154	20.1	1,453					
			20AUA	✓	✓	-	220V/60Hz	370	23.5	1,430	039				
							240V/50Hz	339	23	1,303					
			25AUA	✓	✓	-	220V/60Hz	542	33.2	1,387					
							240V/50Hz	542	31	1,262					
		30AUA	✓	✓	-	220V/60Hz	655	35.3	938						
						240V/50Hz	696	34.8	964						
			20AUH	-	✓	-	220V/60Hz	355	32.4	1,410	040				
							25AUH	-	✓	-		220V/60Hz	514	37.8	1,200
							30AUH 11	-	✓	-		220V/60Hz	572	37.0	866
			20ALA	✓	✓	✓	220V/60Hz	334	23.5	1,398	041				
240V/50Hz							301	23	1,278						
25ALA			✓	✓	✓	220V/60Hz	471	33.2	1,224						
	240V/50Hz					482	32.1	1,217							
30ALA	✓		✓	✓	220V/60Hz	510	35.3	876							
					240V/50Hz	572	35.3	896							



# Product Summary

Product	Series	Model	Silent Stream Fan	Auto Shutter	Louver	Voltage/Frequency	Air Volume [CFM]	Consumption [W]	Page		
Wall Mount Type Ventilation Fan	Plastic Series	10BAQ1	-	-	✓	220V/50Hz	45	15	043		
						220V/60Hz	43	17			
						230V/50Hz	47	16			
						240V/50Hz	50	17.5			
	Bathroom Series	10EGKB	-	-	✓	220V/50Hz	45	4.3	045		
						230V/50Hz	45	4.6			
						240V/50Hz	45	5.0			
		15EGKB	-	-	✓	220V/50Hz	95	5.7			
						230V/50Hz	97	6.1			
						240V/50Hz	97	6.5			
		10EGSB	-	-	✓	220V/50Hz	45	4.3			
						220V/60Hz	51	4.7			
	230V/50Hz					45	4.6				
	240V/50Hz					45	5.0				
	15EGSB					-	-	✓	220V/50Hz	91	5.7
									220V/60Hz	106	6.1
230V/50Hz		94	6.1								
240V/50Hz		97	6.5								



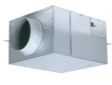
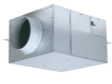
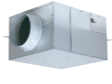

Product	Series	Model	Electrically Operated Shutter	Auto Shutter	Cord-operated Shutter	Voltage/Frequency	Air Volume [CFM]	Consumption [W]	RPM	Page				
Window Mount Type Ventilation Fan	Electric Shutter Series	15WHCT	✓	-	-	220V/60Hz	127	14.6	2,440	050				
						240V/50Hz	127	16	2,537					
						220V/60Hz	250	24.4	1,517					
						240V/50Hz	230	23.4	1,333					
	Automatic Shutter Series	15WAA/ 15WAAMN	-	✓	-	220V/60Hz	124	19.6	2,021	052				
						240V/50Hz	127	18.2	2,062					
						220V/60Hz	250	18.4	1,385					
						20WAA/ 20WAAMN	-	✓	-		240V/50Hz	230	18.6	1,375
											220V/60Hz	105	9.7	1,425
						Cord-operated Shutter Series	15WUD/ 15WUDMN	-	-		-	✓	240V/50Hz	124
	220V/60Hz	188	19.2	980										
	20WUD/ 20WUDMN	-	-	✓	240V/50Hz					221		18.5	1,096	
220V/60Hz					105					9.7		1,425		

# Product Summary

Product	Series	Model	Reversible	Durable Powder Coating	Shutter	Metal Large Blade Assembly	Voltage/Frequency	Air Volume [CFM]	Consumption [W]	RPM	Page	
Industrial Ventilation Fan	Shutter Series		40KAQA	-	✓	✓	✓	220V/50Hz	1,105	47	1,230 - 1,370	056
								230V/50Hz	1,130	52	1,250 - 1,390	
								240V/50Hz	1,155	59	1,270 - 1,410	
								230V/60Hz	1,254	67	1,400 - 1,540	
	High Pressure Series		25GSE	✓	✓	Optional	-	220V/60Hz	788	61	1,570	057
								240V/50Hz	701	48	1,400	
			30GSE	✓	✓	Optional	-	220V/60Hz	1,308	129	1,460	
								240V/50Hz	1,177	106	1,315	
			35GSE	✓	✓	Optional	-	220V/60Hz	1,850	178	1,640	
								240V/50Hz	1,615	130	1,435	
		40GSE	✓	✓	Optional	-	220V/60Hz	2,677	294	1,550	058	
							240V/50Hz	2,135	164	1,440		
			45GSC	✓	✓	Optional	-	220V/60Hz	3,278	346	1,563	059
								240V/50Hz	2,854	277	1,430	
			50GSC	✓	✓	Optional	-	220V/60Hz	3,884	347	1,080	
								240V/50Hz	3,354	293	968	
	60GSC		✓	✓	Optional	-	220V/60Hz	5,038	384	1,088		
							240V/50Hz	4,402	289	980		
		45GTC	✓	✓	Optional	-	220V/50Hz	3,249	220	1,450	060	
							220V/60Hz	3,779	330	1,690		
50GTC		✓	✓	Optional	-	220V/50Hz	4,097	320	1,400			
						220V/60Hz	4,715	475	1,590			
60GTC		✓	✓	Optional	-	220V/50Hz	5,544	310	940			
						220V/60Hz	6,427	450	1,070			

Product	Series	Model	Twin Flow Fan	Noise Absorption Material	Single Phase	Three Phase	Voltage/Frequency	Air Volume [CFM]	Consumption [W]	RPM	Page	
Cabinet Fan	Standard Series		12NSB	✓	✓	✓	-	220V/60Hz	114	26	1,460	065
								240V/50Hz	102	27	1,342	
			15NSB	✓	✓	✓	-	220V/60Hz	200	45	1,520	
								240V/50Hz	193	47	1,373	
			18NSB	✓	✓	✓	-	220V/60Hz	274	80	1,470	066
								240V/50Hz	281	84	1,342	
			18NFB	✓	✓	✓	-	220V/60Hz	417	128	1,420	
								240V/50Hz	429	135	1,327	
			20NSB	✓	✓	✓	-	220V/60Hz	469	170	1,380	067
								240V/50Hz	517	175	1,328	
			23NLB	✓	✓	✓	-	220V/60Hz	655	350	1,400	
								240V/50Hz	688	347	1,342	
	25NSB		✓	✓	✓	-	220V/60Hz	940	460	1,380		
							240V/50Hz	963	481	1,305		
		25NFB	✓	✓	✓	-	220V/60Hz	1,016	680	1,420	068	
							240V/50Hz	1,057	537	1,330		
		25SWC	✓	✓	-	✓	380V/50Hz	2,354	940	1,375		
							380V/60Hz	2,648	1,450	1,530		
		25SMC	✓	✓	-	✓	380V/50Hz	3,060	1,180	1,345	069	
							380V/60Hz	3,237	1,750	1,470		
28NXC		✓	✓	-	✓	380V/50Hz	1,530	600	1,295			
						380V/60Hz	1,560	840	1,380			



# Product Summary

Product		Model	Single Phase	Adjustable Outlet Direction	Page
Mini Sirocco Fan		10CGB	✓	✓	073
		12CGB	✓	✓	
		14CGB	✓	✓	
		16CGB	✓	✓	
		17CGB	✓	✓	
		19CGB	✓	✓	
		21CGB	✓	✓	





Product		Model	Counter-flow Heat-exchange	Bypass Ventilation	Interlock with Air Conditioning	Voltage/Frequnc	Direction	RPM	Page
Energy Recovery Ventilator		E25DZUA	✓	✓	✓	220V/60Hz	OA-SA	1,448	085
							RA-EA	1,378	
		E35DZUA	✓	✓	✓	220V/60Hz	OA-SA	1,425	086
							RA-EA	1,402	
		E50DZUA	✓	✓	✓	220V/60Hz	OA-SA	1,501	087
							RA-EA	1,452	







Product		Model	Ventilation	Circulation	Heating	Clothes Drying	Voltage/Frequency	Air Volume		Page	
								[CMH]	[CFM]		
Thermo Ventilator		30BUC	✓	✓	✓	✓	220V/60Hz	160	94	091	

Product	Twin Motor Series	Model	2-speed Selection	Slim Design	Voltage/Frequency	Air Volume		RPM	Page
						[CMH]	[CFM]		
Range Hood		90HQUA	✓	✓	220V/50Hz (Hi)	785	462	993	095
					220V/50Hz (Lo)	484	285	570	
					220V/60Hz (Hi)	779	459	905	
					220V/60Hz (Lo)	464	273	594	
					240V/50Hz (Hi)	775	456	911	
					240V/50Hz (Lo)	523	308	-	

Product	Standard Series	Model	Quick Response Sensor	Lamp Super alleru-buster Filter	ON/OFF Switch for Heater	Safety Check Indicator	Voltage/Frequency	Air Velocity [m/s]	Page
Hand Dryer		T09AC	✓	✓	✓	✓	220V/50Hz	90 - 110	099
							220V/60Hz	90 - 110	
							230V/50Hz	90 - 110	
							230V/60Hz	90 - 110	
		T09BC	✓	✓	✓	✓	220V/50Hz	90 - 110	
							220V/60Hz	90 - 110	
							230V/50Hz	90 - 110	
							230V/60Hz	90 - 110	

# Product Summary

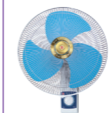
Product	Type	Series	Model	Cross Flow Fan	Sirocco Fan	Meta Blade Bush	Air Deflection Plate	2-speed Selection	Remote Control	Door Contact Sensor	Push Button Switch	Page		
<b>Air Curtaina</b>	<b>Cross Flow Type</b>	<b>Remote Control Series</b>	 3009GA	✓	-	✓	✓	✓	✓	-	-	103		
			4009GA	✓	-	✓	✓	✓	✓	-	-			
			3012GA	✓	-	✓	✓	✓	✓	-	-			
			4012GA	✓	-	✓	✓	✓	✓	-	-			
			3015GA	✓	-	✓	✓	✓	✓	-	-			
			4015GA	✓	-	✓	✓	✓	✓	-	-			
		<b>Sensor Series</b>	 3009DA	✓	-	✓	✓	✓	-	✓	-	-	104	
			4009DA	✓	-	✓	✓	✓	-	✓	-			
			3012DA	✓	-	✓	✓	✓	-	✓	-			
			4012DA	✓	-	✓	✓	✓	-	✓	-			
			3015DA	✓	-	✓	✓	✓	-	✓	-			
			4015DA	✓	-	✓	✓	✓	-	✓	-			
	<b>Standard Series</b>	 3009UA	✓	-	✓	✓	✓	-	-	✓	-	105		
		4009UA	✓	-	✓	✓	✓	-	-	✓				
		3012UA	✓	-	✓	✓	✓	-	-	✓				
		4012UA	✓	-	✓	✓	✓	-	-	✓				
		3015UA	✓	-	✓	✓	✓	-	-	✓				
		4015UA	✓	-	✓	✓	✓	-	-	✓				
	<b>Sirocco Type</b>	<b>900 Series</b>	 08ESK	-	✓	-	✓	✓	-	-	✓	107		
			10ESK	-	✓	-	✓	✓	-	-	✓			
			12ESK	-	✓	-	✓	✓	-	-	✓			
			14ESK	-	✓	-	✓	✓	-	-	✓			
			<b>1200 Series</b>	 08ELK	-	✓	-	✓	✓	-	-		✓	108
				10ELK	-	✓	-	✓	✓	-	-		✓	
12ELK		-		✓	-	✓	✓	-	-	✓				
14ELK		-		✓	-	✓	✓	-	-	✓				

Product	Series	Model	Remote Control	Regulator Control	Pull Switch	3-speed Selection	5-speed Selection	OFF Timer	Metal Blades	360° Oscillation	Page		
<b>Ceiling Fan</b>	<b>Remote Control Series</b>	 U56PR	✓	-	-	✓	-	✓	✓	-	111		
		 T48XC	T48XC	-	✓	-	-	✓	-	✓	-	112	
	T56XC		-	✓	-	-	✓	-	✓	-			
	T48XG		-	✓	-	-	✓	-	✓	-	113		
	T56XG	-	✓	-	-	✓	-	✓	-				
	 X48XC	X48XC	-	✓	-	-	✓	-	✓	-	114		
		X56XC	-	✓	-	-	✓	-	✓	-			
		 X48XG	X48XG	-	✓	-	-	✓	-	✓	-	115	
			X56XG	-	✓	-	-	✓	-	✓	-		
		<b>Electric Fan</b>	<b>Orbital Fan</b>	 M40R	-	✓	-	-	✓	-	✓	✓	116
			<b>Wall Fan</b>	 M30C	M30C	-	-	✓	✓	-	-	-	117
	M40C				-	-	✓	✓	-	✓	-		
	 M40M			✓	-	-	✓	-	✓	-	-	118	
	 YU50X		-	-	✓	✓	-	✓	✓	-	119		

# Ceiling Mount Type Ventilation Fan



24CMUA / 24CMHA / 27CMHA



\*Metallic structure can reduce the fire risk spread to other area from fire affected compartment through the ducting.

# DC Motor Series

Usage: Bathroom Toilet Living Room / Corridor / Office / Retail Store

## 24JRB

24-Hour Ventilation

Installation 230 x 230mm

Duct Type Ø100mm



- DC (Direct Current) motor
- Auto operation by motion sensor
- Constant airflow
- Automated air volume adjustment
- Delay timer (15 minutes)
- Resonance-Noise-Absorption Structure
- Motor insulation Class E
- IP protection: IPX2

Dimension Unit : mm

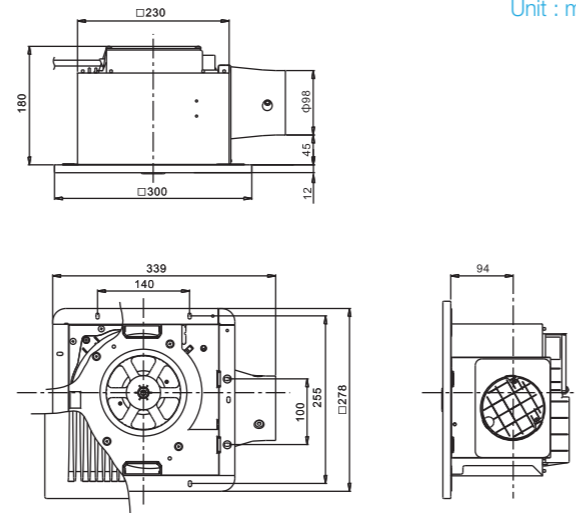

KDK Company, Division of PES and Panasonic Ecology Systems Guangdong Co., Ltd. certifies that the Ceiling Mount Type Ventilation Fan – DC Motor Series shown herein are licensed to bear the AMCA Seal. The ratings shown are based on tests and procedures performed in accordance with AMCA Publication 211 and AMCA Publication 311 and comply with the requirements of the AMCA Certified Ratings Program.

### Specification

Model	Voltage [V]	Frequency [Hz]	Speed	CFM / SONE AT STATIC Pressure (ps-inches of H <sub>2</sub> O)								RPM	Watts*	Watts**
				Inches of H <sub>2</sub> O	0	0.1	0.125	0.25	0.375	0.5	0.625			
24JRB	220	60	Hi	CFM	88	88	88	88	63	34	5	853	10	8
				Sones	0.7	1.0	1.0	1.3	1.7	1.8	3.1			
	240	50	Hi	CFM	88	88	88	88	63	34	5			
				Sones	0.7	1.0	1.0	1.3	1.7	1.8	3.1			

Performance certified is for installation type B: Free inlet, Ducted outlet. Performance ratings include the effects of an inlet grille and backdraft shutter. Speed (RPM) shown is nominal. Performance is based on actual speed of test. The sound ratings shown are loudness values in fan sones at 5 ft. (1.5m) in a hemispherical free field calculated per AMCA International Standard 301. Values shown are for installation type B: Free inlet hemispherical sone levels.

\* the Watts rating is only for AMCA test method and it is at the static pressure of 0 inch of H<sub>2</sub>O.

\*\* the Watts rating is only for IEC test method and the AMCA Certified Ratings Seal does not apply to IEC test method watts.

### Installation Example

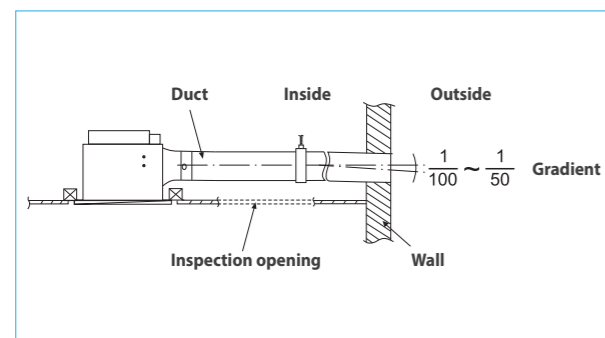

### Wiring Diagram

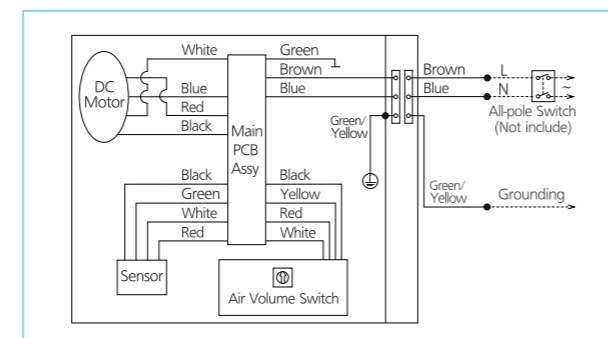

# DC Motor Series

Usage: Bathroom Toilet Living Room / Corridor / Office / Retail Store

## 24JAB

24-Hour Ventilation

Installation 230 x 230mm

Duct Type Ø100mm



- DC (Direct Current) motor
- Constant airflow
- Automated air volume adjustment
- Delay timer (15 minutes)
- Resonance-Noise-Absorption Structure
- Motor insulation Class E
- IP protection: IPX2

Dimension Unit : mm

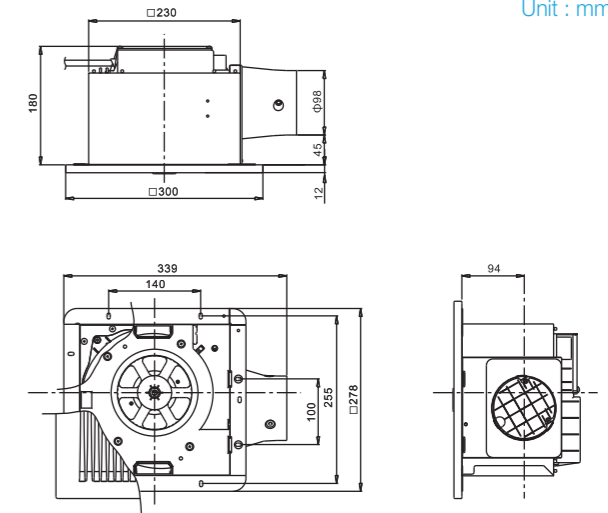

KDK Company, Division of PES and Panasonic Ecology Systems Guangdong Co., Ltd. certifies that the Ceiling Mount Type Ventilation Fan – DC Motor Series shown herein are licensed to bear the AMCA Seal. The ratings shown are based on tests and procedures performed in accordance with AMCA Publication 211 and AMCA Publication 311 and comply with the requirements of the AMCA Certified Ratings Program.

### Specification

Model	Voltage [V]	Frequency [Hz]	Speed	CFM / SONE AT STATIC Pressure (ps-inches of H <sub>2</sub> O)								RPM	Watts*	Watts**
				Inches of H <sub>2</sub> O	0	0.1	0.125	0.25	0.375	0.5	0.625			
24JAB	220	60	Hi	CFM	88	88	88	88	63	34	5	839	10	8
				Sones	0.6	0.9	1.0	1.4	1.6	1.9	3.2			
	240	50	Hi	CFM	88	88	88	88	63	34	5			
				Sones	0.6	0.9	1.0	1.4	1.6	1.9	3.2			

Performance certified is for installation type B: Free inlet, Ducted outlet. Performance ratings include the effects of an inlet grille and backdraft shutter. Speed (RPM) shown is nominal. Performance is based on actual speed of test. The sound ratings shown are loudness values in fan sones at 5 ft. (1.5m) in a hemispherical free field calculated per AMCA International Standard 301. Values shown are for installation type B: Free inlet hemispherical sone levels.

\* the Watts rating is only for AMCA test method and it is at the static pressure of 0 inch of H<sub>2</sub>O.

\*\* the Watts rating is only for IEC test method and the AMCA Certified Ratings Seal does not apply to IEC test method watts.

### Installation Example

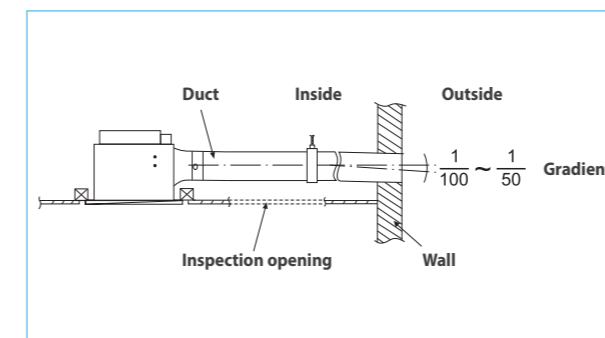

### Wiring Diagram

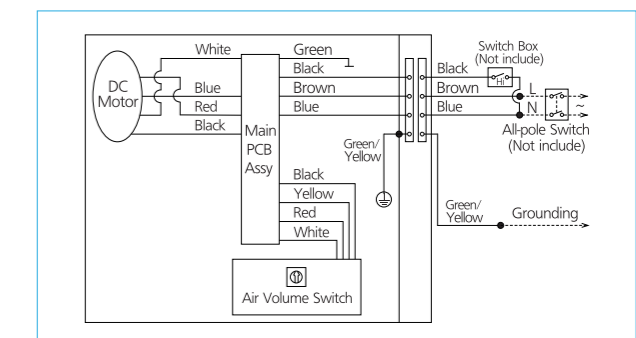

# Super Quiet Series

Usage: Bathroom Toilet Living Room / Corridor / Office / Retail Store

## 17CUH

24-Hour Ventilation

Installation 170 x 170mm

Duct Type Ø100mm



### Dimension

Unit : mm

A	B	C	D	E	F	G	Duct Size
214	194	84	164	170	240	20	Ø100

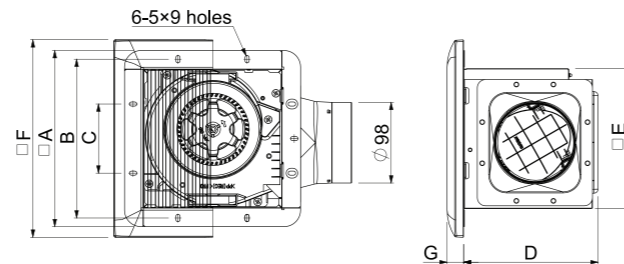

- Half pitch condenser motor with thermal cut-off
- Well-lubricated ball bearing for long life operation
- Effective control of air turbulence with taper blade
- Curve-shaped backdraft shutter
- Super low noise
- Motor insulation Class B
- IP protection: IPX2

Panasonic Electric Works Vietnam Co., Ltd. certifies that the Ceiling Mount Type Ventilation Fan – Super Quiet Series shown herein are licensed to bear the AMCA Seal. The ratings shown are based on tests and procedures performed in accordance with AMCA Publication 211 and AMCA Publication 311 and comply with the requirements of the AMCA Certified Ratings Program.



### Specification

Model	Voltage [V]	Frequency [Hz]	CFM / SONE AT STATIC Pressure (ps-inches of H <sub>2</sub> O)			RPM	Watts* FOR AMCA	Watts** FOR IEC	
			Inches of H <sub>2</sub> O	0	0.1				0.125
17CUH	220	60	CFM	44	32	29	664	10	10
			Sones	0.3	0.5	0.6			
	240	50	CFM	51	43	40	728	10	9.5
			Sones	0.3	0.4	0.5			

Performance certified is for installation type B: Free inlet, Ducted outlet. Performance ratings include the effects of an inlet grille and backdraft shutter. Speed (RPM) shown is nominal. Performance is based on actual speed of test. The sound ratings shown are loudness values in fan sones at 5 ft. (1.5m) in a hemispherical free field calculated per AMCA International Standard 301. Values shown are for installation type B: Free inlet hemispherical sone levels.

\* the Watts rating is for AMCA test method and it is at the static pressure of 0 inch of H<sub>2</sub>O.

\*\* the Watts rating is only for IEC test method and the AMCA Certified Rating Seal does not apply to IEC test method watts.

### Installation Example

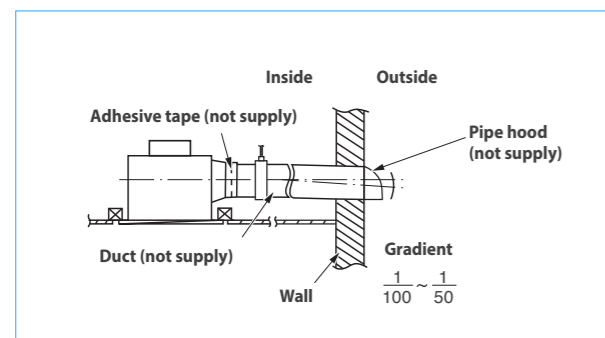

### Wiring Diagram

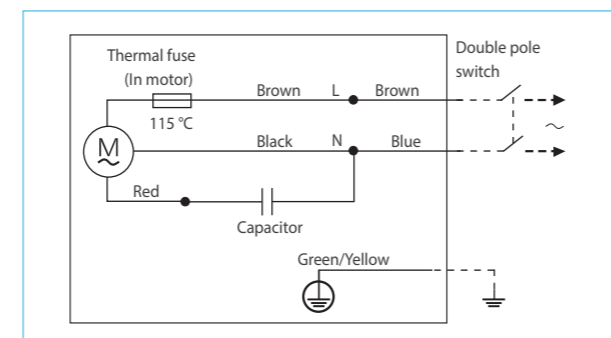

# Super Quiet Series

Usage: Bathroom Toilet Living Room / Corridor / Office / Retail Store

## 24CUH / 24CDH / 24CHH

24-Hour Ventilation

Installation 233 x 233mm

Duct Type Ø100mm



### Dimension

Unit : mm

A	B	C	D	E	F	G	Duct Size
278	255	140	175	233	300	13	Ø100

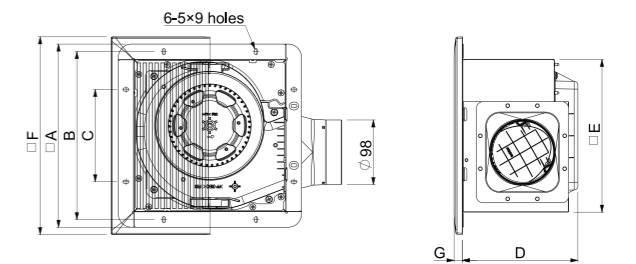

- Half pitch condenser motor with thermal cut-off
- Well-lubricated ball bearing for long life operation
- Effective control of air turbulence with taper blade
- Curve-shaped backdraft shutter
- Super low noise
- Motor insulation Class B
- IP protection: IPX2

Panasonic Electric Works Vietnam Co., Ltd. certifies that the Ceiling Mount Type Ventilation Fan – Super Quiet Series shown herein are licensed to bear the AMCA Seal. The ratings shown are based on tests and procedures performed in accordance with AMCA Publication 211 and AMCA Publication 311 and comply with the requirements of the AMCA Certified Ratings Program.



### Specification

Model	Voltage [V]	Frequency [Hz]	CFM / SONE AT STATIC Pressure (ps-inches of H <sub>2</sub> O)					RPM	Watts* FOR AMCA	Watts** FOR IEC	
			Inches of H <sub>2</sub> O	0	0.1	0.125	0.25				0.375
24CUH	220	60	CFM	83	73	68	46	-	585	13	13.5
			Sones	0.4	0.5	0.6	1.3	-			
	240	50	CFM	89	77	75	51	-	614	13	12
			Sones	0.5	0.7	0.7	1.4	-			
24CDH	240	50	CFM	106	93	89	65	-	782	17	16.5
			Sones	0.9	0.9	0.9	1.6	-			
24CHH	220	60	CFM	109	99	96	75	48	791	22	20.5
			Sones	1.0	0.9	1.0	1.3	2.2			
	240	50	CFM	117	109	96	73	33	861	21	19.5
			Sones	1.2	1.2	1.2	1.3	1.8			

Performance certified is for installation type B: Free inlet, Ducted outlet. Performance ratings include the effects of an inlet grille and backdraft shutter. Speed (RPM) shown is nominal. Performance is based on actual speed of test. The sound ratings shown are loudness values in fan sones at 5 ft. (1.5m) in a hemispherical free field calculated per AMCA International Standard 301. Values shown are for installation type B: Free inlet hemispherical sone levels.

\* the Watts rating is for AMCA test method and it is at the static pressure of 0 inch of H<sub>2</sub>O.

\*\* the Watts rating is only for IEC test method and the AMCA Certified Rating Seal does not apply to IEC test method watts.

### Installation Example

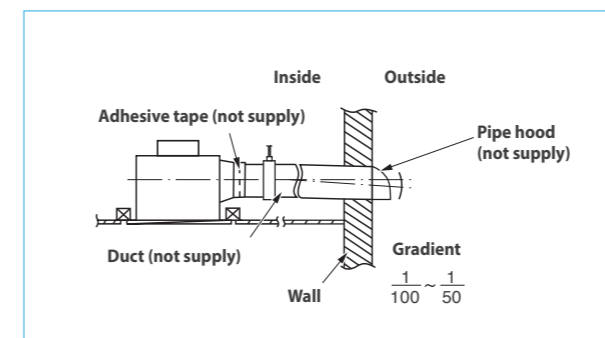

### Wiring Diagram

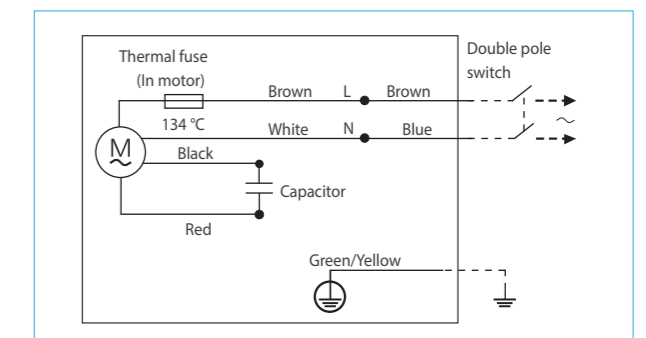

# Super Quiet Series

Usage: Bathroom Toilet Living Room / Corridor / Office / Retail Store

## 24CXH

24-Hour Ventilation

Installation 233 x 233mm

Duct Type Ø100mm



- Half pitch condenser motor with thermal cut-off
- Well-lubricated ball bearing for long life operation
- Effective control of air turbulence with taper blade
- Curve-shaped backdraft shutter
- Super low noise
- Motor insulation Class B
- IP protection: IPX2

### Dimension

Unit : mm

A	B	C	D	E	F	G	Duct Size
278	255	140	175	233	300	13	Ø100

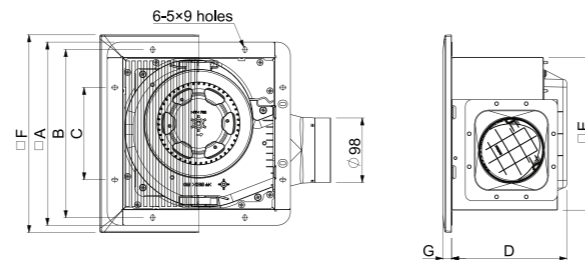

Panasonic Electric Works Vietnam Co., Ltd. certifies that the Ceiling Mount Type Ventilation Fan – Super Quiet Series shown herein are licensed to bear the AMCA Seal. The ratings shown are based on tests and procedures performed in accordance with AMCA Publication 211 and AMCA Publication 311 and comply with the requirements of the AMCA Certified Ratings Program.



### Specification

Model	Voltage [V]	Frequency [Hz]	CFM / SONE AT STATIC Pressure (ps-inches of H <sub>2</sub> O)					RPM	Watts* FOR AMCA	Watts** FOR IEC
			Inches of H <sub>2</sub> O	0	0.1	0.125	0.25			
24CXH	220	50	CFM	tbc	tbc	tbc	tbc	tbc	tbc	tbc
			Sones							
	230	50	CFM							
			Sones							
240	50	CFM								
		Sones								

Performance certified is for installation type B: Free inlet, Ducted outlet. Performance ratings include the effects of an inlet grille and backdraft shutter. Speed (RPM) shown is nominal. Performance is based on actual speed of test. The sound ratings shown are loudness values in fan sones at 5 ft. (1.5m) in a hemispherical free field calculated per AMCA International Standard 301. Values shown are for installation type B: Free inlet hemispherical sone levels.

\* the Watts rating is for AMCA test method and it is at the static pressure of 0 inch of H<sub>2</sub>O.

\*\* the Watts rating is only for IEC test method and the AMCA Certified Rating Seal does not apply to IEC test method watts.

### Installation Example

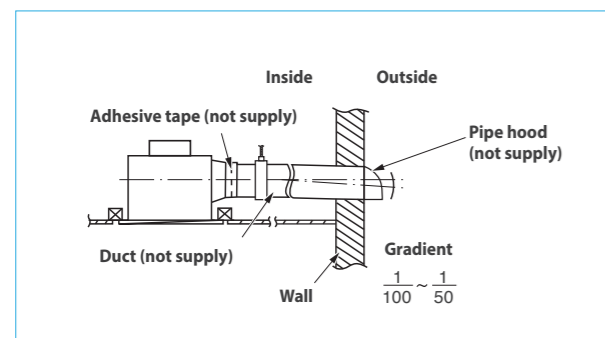

### Wiring Diagram

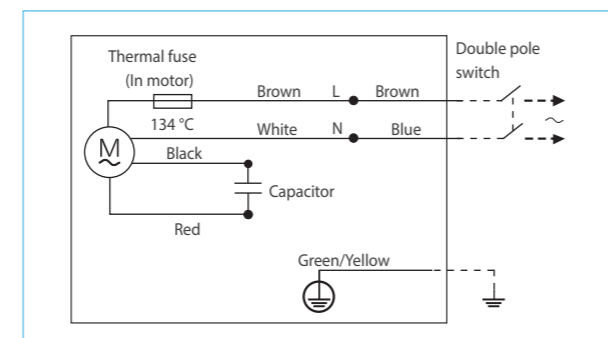

# Super Quiet Series

Usage: Bathroom Toilet Living Room / Corridor / Office / Retail Store

## 27CHH

24-Hour Ventilation

Installation 260 x 260mm

Duct Type Ø150mm



- Super low noise
- Long life ball bearing motor
- Effective control of air turbulence with taper blade
- Resonance-Noise-Absorption Structure
- Pre-installed power cord
- 2 speed selectable
- Motor insulation Class E
- IP protection: IPX2

### Dimension

Unit : mm

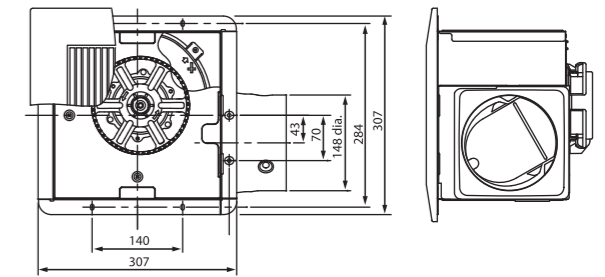
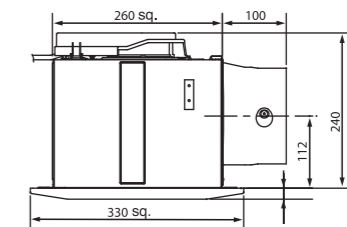

KDK Company, Division of PES and Panasonic Ecology Systems Guangdong Co., Ltd. certifies that the Ceiling Mount Type Ventilation Fan – Super Quiet Series shown herein are licensed to bear the AMCA Seal. The ratings shown are based on tests and procedures performed in accordance with AMCA Publication 211 and AMCA Publication 311 and comply with the requirements of the AMCA Certified Ratings Program.



### Specification

Model	Voltage [V]	Frequency [Hz]	Speed	CFM / SONE AT STATIC Pressure (ps-inches of H <sub>2</sub> O)						RPM	Watts* FOR AMCA	Watts** FOR IEC	
				Inches of H <sub>2</sub> O	0	0.1	0.125	0.25	0.375				0.5
27CHH	220	60	Hi	CFM	182	162	156	118	78	37	570	33	33
				Sones	1.1	1.2	1.3	1.7	2.2	2.5			
	240	50	Hi	CFM	198	179	172	126	78	18	609	37	34
				Sones	1.4	1.5	1.6	1.8	2.3	2.5			

Performance certified is for installation type B: Free inlet, Ducted outlet. Performance ratings include the effects of an inlet grille and backdraft shutter. Speed (RPM) shown is nominal. Performance is based on actual speed of test. The sound ratings shown are loudness values in fan sones at 5 ft. (1.5m) in a hemispherical free field calculated per AMCA International Standard 301. Values shown are for installation type B: Free inlet hemispherical sone levels.

\* the Watts rating is for AMCA test method and it is at the static pressure of 0 inch of H<sub>2</sub>O.

\*\* the Watts rating is only for IEC test method and the AMCA Certified Rating Seal does not apply to IEC test method watts.

### Installation Example

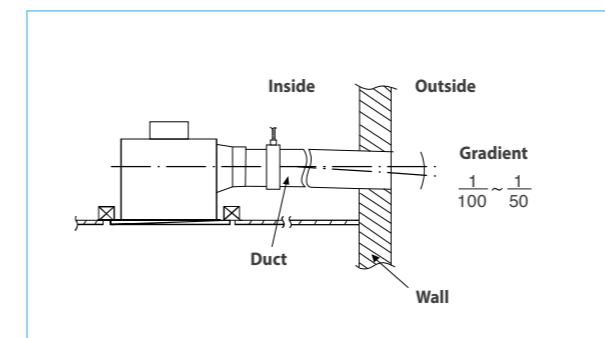

### Wiring Diagram

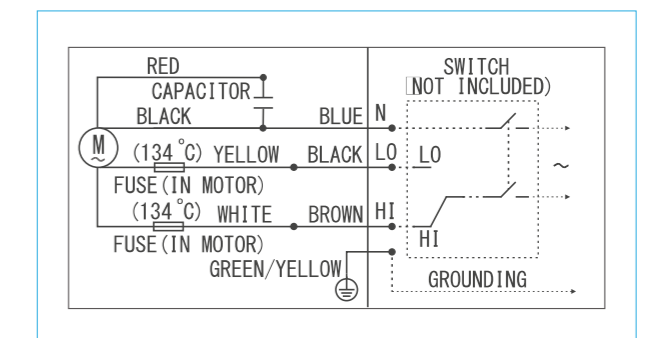

# Super Quiet Series

Usage: Bathroom Toilet Living Room / Corridor / Office / Retail Store

## 32CDH

- 24-Hour Ventilation
- Installation 310 x 310mm
- Duct Type Ø150mm

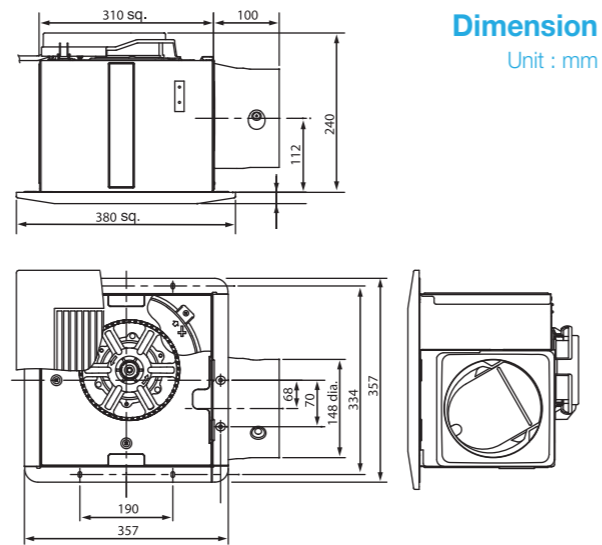

Dimension  
Unit : mm

- Half pitch condenser motor with thermal cut-off
- Well-lubricated ball bearing for long life operation
- Effective control of air turbulence with taper blade
- Curve-shaped backdraft shutter
- Super low noise
- Motor insulation Class E
- IP protection: IPX2

KDK Company, Division of PES and Panasonic Ecology Systems Guangdong Co., Ltd. certifies that the Ceiling Mount Type Ventilation Fan – Super Quiet Series shown herein are licensed to bear the AMCA Seal. The ratings shown are based on tests and procedures performed in accordance with AMCA Publication 211 and AMCA Publication 311 and comply with the requirements of the AMCA Certified Ratings Program.

### Specification

Model	Voltage [V]	Frequency [Hz]	Speed	CFM / SONE AT STATIC Pressure (ps-inches of H <sub>2</sub> O)								RPM	Watts*	
				Inches of H <sub>2</sub> O	0	0.1	0.125	0.25	0.375	0.5	0.625		FOR AMCA	FOR IEC
32CDH	220	60	Hi	CFM	226	202	196	163	127	91	53	580	48	48
				Sones	1.2	1.3	1.4	1.7	2.2	2.7	3.3			
	240	50	Hi	CFM	257	236	230	192	147	99	53	675	56	50
				Sones	1.6	1.7	1.8	1.9	2.5	3.0	3.6			

Performance certified is for installation type B: Free inlet, Ducted outlet. Performance ratings include the effects of an inlet grille and backdraft shutter. Speed (RPM) shown is nominal. Performance is based on actual speed of test. The sound ratings shown are loudness values in fan sones at 5 ft. (1.5m) in a hemispherical free field calculated per AMCA International Standard 301. Values shown are for installation type B: Free inlet hemispherical sone levels.

\* the Watts rating is for AMCA test method and it is at the static pressure of 0 inch of H<sub>2</sub>O.

\*\* the Watts rating is only for IEC test method and the AMCA Certified Rating Seal does not apply to IEC test method watts.

### Installation Example

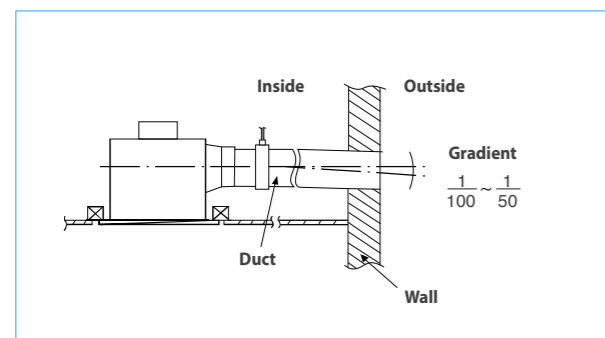

### Wiring Diagram

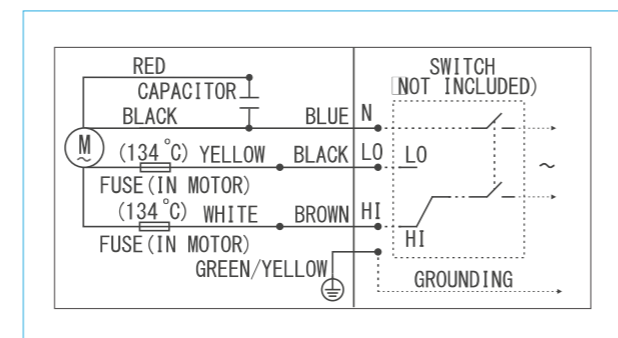

# Standard Series

Usage: Bathroom Toilet Living Room / Corridor / Office / Retail Store

## 38CDG / 38CDG 05

- 24-Hour Ventilation
- Installation 375 x 375mm
- Duct Type Ø150mm

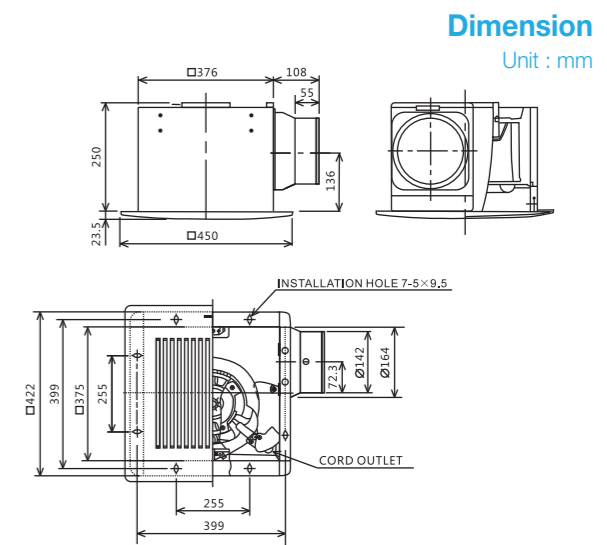

Dimension  
Unit : mm

- High-Low speed selectable
- Condenser motor with thermal cut-off
- Well-lubricated ball bearing for long life operation
- High performance sirocco fan
- Motor insulation Class E

KDK Company, Division of PES and Panasonic Ecology Systems Guangdong Co., Ltd. certifies that the Ceiling Mount Type Ventilation Fan – Standard Series shown herein are licensed to bear the AMCA Seal. The ratings shown are based on tests and procedures performed in accordance with AMCA Publication 211 and AMCA Publication 311 and comply with the requirements of the AMCA Certified Ratings Program.

### Specification

Model	Voltage [V]	Frequency [Hz]	Speed	CFM / SONE AT STATIC Pressure (ps-inches of H <sub>2</sub> O)										RPM	Watts*	
				Inches of H <sub>2</sub> O	0	0.1	0.125	0.25	0.375	0.5	0.625	0.75	0.875		FOR AMCA	FOR IEC
38CDG	220	60	Hi	CFM	344	323	317	290	261	230	197	163	126	626	98	98
				Sones	3.1	3.2	3.2	3.3	3.6	4.1	4.5	5.7	5.7			
				Inches of H <sub>2</sub> O	0	0.1	0.125	0.25	0.375	0.5	0.625	0.75	0.875			
38CDG 05 38CDG	240	50	Hi	CFM	387	367	362	336	305	259	212	165	108	737	118	104
				Sones	4.0	4.1	4.2	4.3	4.4	4.7	5.3	5.7	6.2			
				Inches of H <sub>2</sub> O	0	0.1	0.125	0.25	0.375	0.5	0.625	0.75	0.875			

Performance certified is for installation type B: Free inlet, Ducted outlet. Performance ratings include the effects of an inlet grille and backdraft shutter. Speed (RPM) shown is nominal. Performance is based on actual speed of test. The sound ratings shown are loudness values in fan sones at 5 ft. (1.5m) in a hemispherical free field calculated per AMCA International Standard 301. Values shown are for installation type B: Free inlet hemispherical sone levels.

\* the Watts rating is only for AMCA test method and it is at the static pressure of 0 inch of H<sub>2</sub>O.

\*\* the Watts rating is only for IEC test method and the AMCA Certified Ratings Seal does not apply to IEC test method watts.

### Installation Example

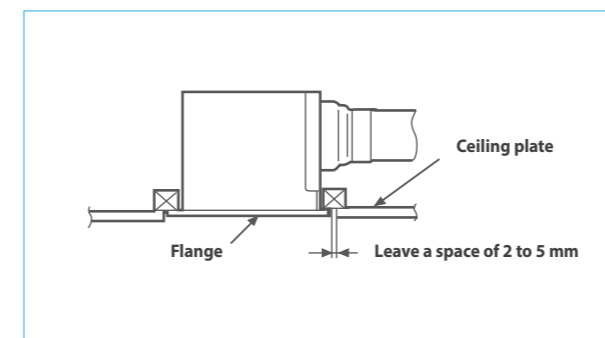

### Wiring Diagram

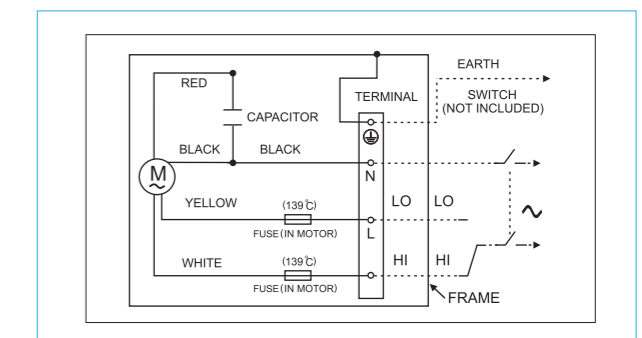

# Standard Series

Usage: Bathroom Toilet Living Room / Corridor / Office / Retail Store

## 38CHG

24-Hour Ventilation

Installation 375 x 375mm

Duct Type Ø150mm



- Condenser motor with thermal cut-off
- Well-lubricated ball bearing for long life operation
- Effective control of air turbulence with taper blade
- Reverse flow prevention shutter
- 2 speed selectable
- Motor insulation Class E
- IP protection: IPX2

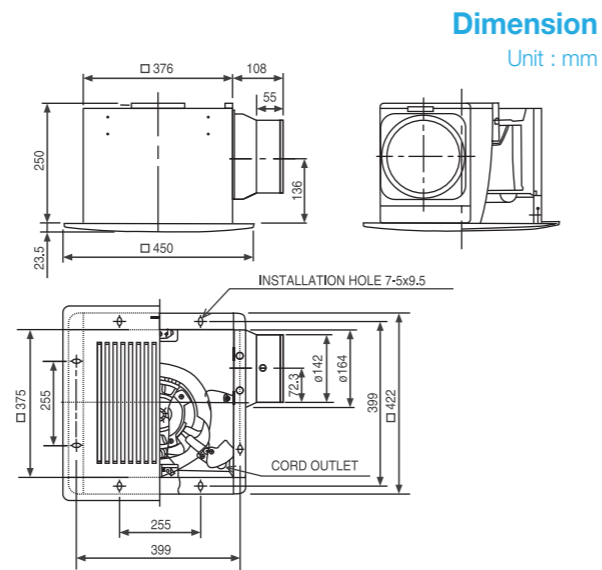

### Performance Data

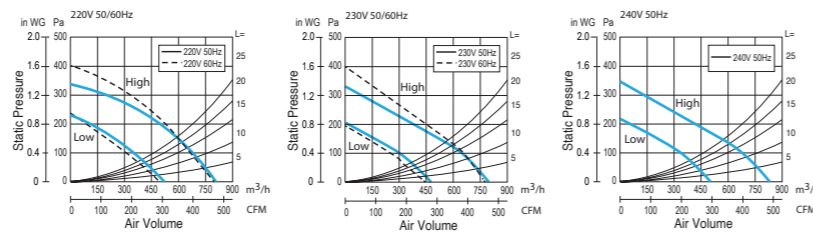

### Specification

Model	Voltage [V]	Frequency [Hz]	Air Volume		Consumption [W]	RPM	Noise [dB(A)]	Weight [kg]	Installation Space [mm]	Duct Size [mm]	
			[CMH]	[CFM]							
38CHG	220	50	Hi	800	471	122	790	49.5	10.4	385 x 385	Ø150
			Lo	525	309	89	540	39.5			
	60	Hi	790	465	138	760	49				
		Lo	500	294	90	509	39				
	230	50	Hi	800	471	122	775	49			
			Lo	470	277	84	485	37			
240	50	Hi	835	491	132	807	50				
		Lo	490	288	90	504	38				

Note: RPM data is for reference only, values may vary subject to different conditions

Test Condition

- Air volume, electric characteristic and noise are specified at the static pressure of 0 Pa
- The values of noise level is A weighted average sound pressure level, the mean values are measured by our company, within +3 to -7 dB tolerance
- The values of noise level are measured at 1 m apart from the side of fan body when ducts are connected on outlet side
- The values of air volume are the mid-points of results measured by our company, within ±10% tolerance

### Installation Example

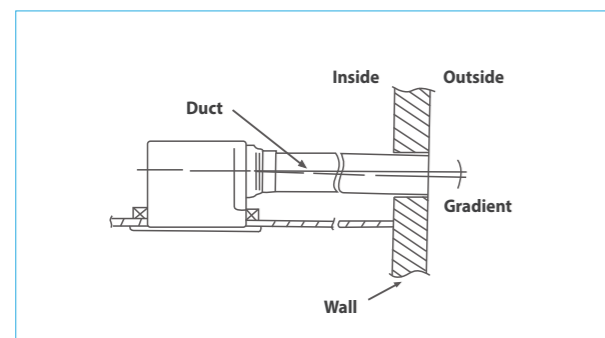

### Wiring Diagram

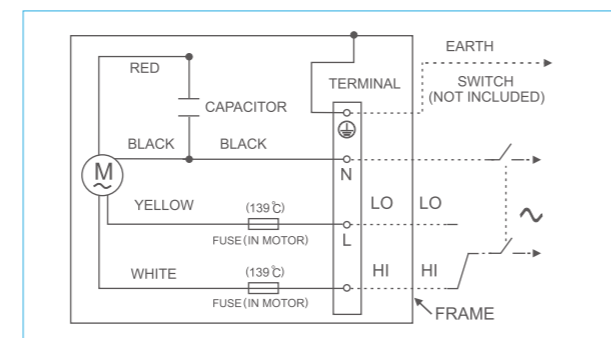

# Metal Series

Usage: Bathroom Toilet Living Room / Corridor / Office / Retail Store

## 24CMUA / 24CMHA

Fire Resistant

24-Hour Ventilation

Installation 240 x 240mm

Duct Type Ø100mm



- All-metal structure design
- Well-lubricated ball bearing for long life operation
- Metallic components to improve fire resistance
- Reverse flow prevention shutter
- Motor insulation Class E
- IP protection: IPX2

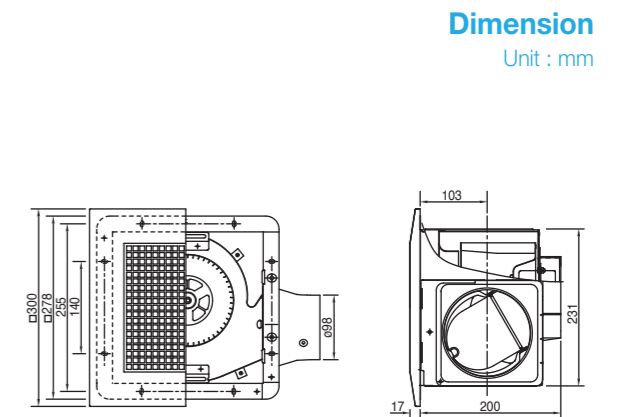

### Specification

Model	Voltage [V]	Frequency [Hz]	CFM / SONE AT STATIC Pressure (ps-inches of H <sub>2</sub> O)					RPM	Watts*	Watts**	
			Inches of H <sub>2</sub> O	0	0.1	0.125	0.25		0.375	FOR AMCA	FOR IEC
24CMUA	220	60	CFM	55	40	37	20	-	495	13	12
			Sones	0.3	0.7	0.8	1.6	-			
24CMUA	240	50	CFM	55	44	41	24	-	562	14	13
			Sones	0.3	0.8	1.0	1.4	-			
24CMHA	220	60	CFM	94	85	83	72	54	681	25	23
			Sones	1.0	1.4	1.5	1.9	2.3			
24CMHA	240	50	CFM	108	98	95	77	44	753	27	25
			Sones	1.4	1.8	1.9	2.1	2.2			

Performance certified is for installation type B: Free inlet, Ducted outlet. Performance ratings include the effects of an inlet grille and backdraft shutter. Speed (RPM) shown is nominal. Performance is based on actual speed of test. The sound ratings shown are loudness values in fan sones at 5 ft. (1.5m) in a hemispherical free field calculated per AMCA International Standard 301. Values shown are for installation type B: Free inlet hemispherical sone levels.

\* the Watts rating is only for AMCA test method and it is at the static pressure of 0 inch of H<sub>2</sub>O.

\*\* the Watts rating is only for IEC test method and the AMCA Certified Ratings Seal does not apply to IEC test method watts.

### Installation Example

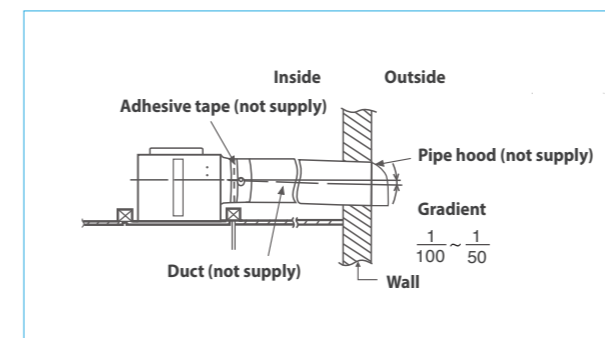

### Wiring Diagram

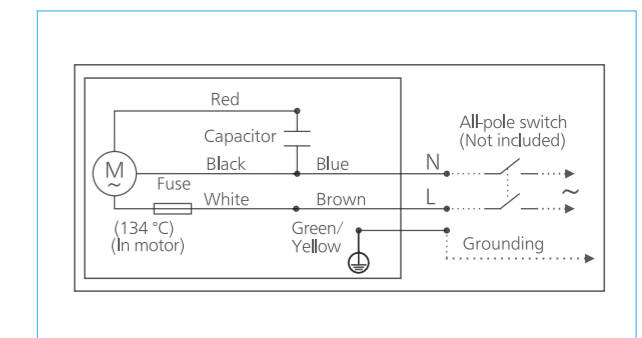

# Metal Series

Usage: Bathroom Toilet Living Room / Corridor / Office / Retail Store

## 27CMHA

- Fire Resistant
- 24-Hour Ventilation
- Installation 270 x 270mm
- Duct Type Ø148mm



- All-metal structure design
- Well-lubricated ball bearing for long life operation
- Metallic components within air stream provides extra safety against fire
- Reverse flow prevention shutter
- Motor insulation Class E
- IP protection: IPX2

### Dimension Unit : mm

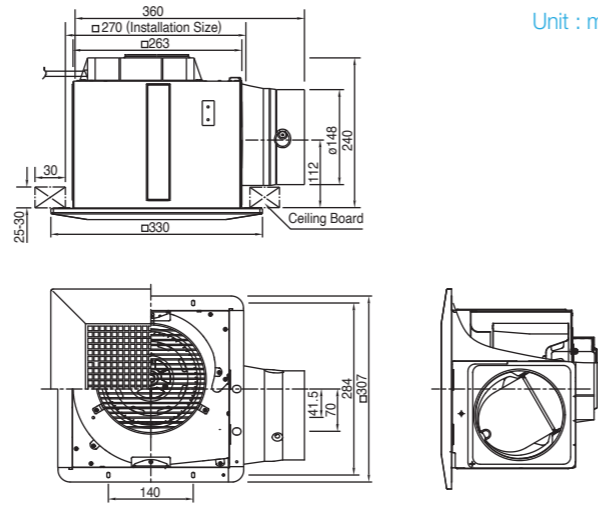

KDK Company, Division of PES and Panasonic Ecology Systems Guangdong Co., Ltd. certifies that the Ceiling Mount Type Ventilation Fan – Metal Series shown herein are licensed to bear the AMCA Seal. The ratings shown are based on tests and procedures performed in accordance with AMCA Publication 211 and AMCA Publication 311 and comply with the requirements of the AMCA Certified Ratings Program.

### Specification

Model	Voltage [V]	Frequency [Hz]	CFM / SONE AT STATIC Pressure (ps-inches of H <sub>2</sub> O)							RPM	Watts*	Watts**
			Inches of H <sub>2</sub> O	0	0.1	0.125	0.25	0.375	0.5			
27CMHA	220	60	CFM	208	184	178	144	108	79	615	46	43
			Sones	1.6	1.7	1.7	2.3	3.2	3.5			
	240	50	CFM	219	194	188	150	110	70	669	46	43
			Sones	1.9	1.9	2.0	2.4	3.4	3.1			

Performance certified is for installation type B: Free inlet, Ducted outlet. Performance ratings include the effects of an inlet grille and backdraft shutter. Speed (RPM) shown is nominal. Performance is based on actual speed of test. The sound ratings shown are loudness values in fan sones at 5 ft. (1.5m) in a hemispherical free field calculated per AMCA International Standard 301. Values shown are for installation type B: Free inlet hemispherical sone levels.

\* the Watts rating is only for AMCA test method and it is at the static pressure of 0 inch of H<sub>2</sub>O.

\*\* the Watts rating is only for IEC test method and the AMCA Certified Ratings Seal does not apply to IEC test method watts.

### Installation Example

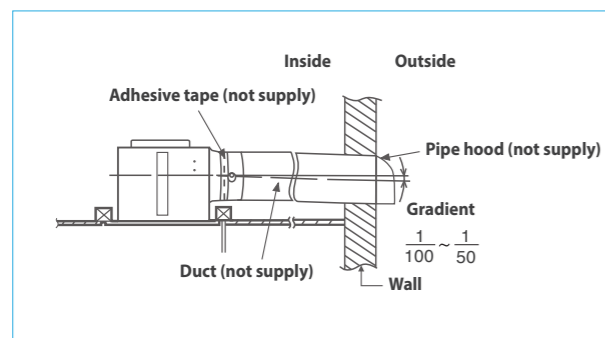

### Wiring Diagram

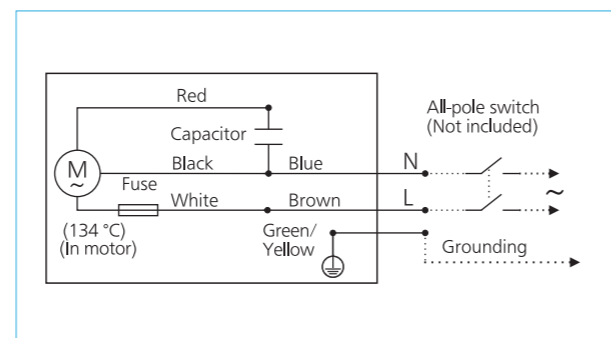

# Wall Mount Type Ventilation Fan



24 Hours Ventilation



Contemporary



Safe



Low-Noise



Scan for more information



## Features

### Smart Design

The new flat design creates a feeling of floating upon installation on wall. Meanwhile, slim louver is designed for the louver series. Such minimalistic elements integrate seamlessly with the interior space.

Only applicable for model:  
20AUA/25AUA/30AUA  
20ALA/25ALA/30ALA

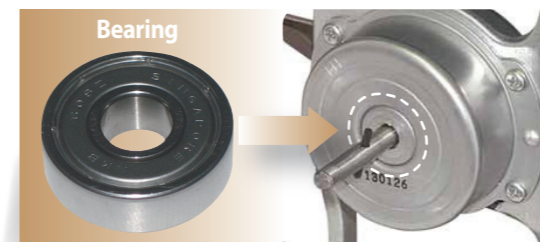

Bearing

### Half Pitch Motor & Bearing

All models adopt half pitch capacitor induction motor and long life bearing that prolongs the product durability, with average 30,000 hours life. They also enable energy saving by reducing power consumption down to average 13%.

### Thermal Fuse Equipped

All motors are equipped with thermal fuses which would stop when they are overheated. It can prevent further temperature rise and minimize the risk of fire hazard.



Silent Stream Fan

### Silent Stream Fan

New Blade design applies advanced aerodynamic principle that optimizes the blade shape.

Only applicable for model:  
20AUA/25AUA/30AUA  
20ALA/25ALA/30ALA



### 3D Sickle Blade

New Blade design adopts an increased blade size and airfoil curve optimization. It can increase the air volume by the adjusted blade shape which can match the airflow. Furthermore, it can lower the noise by evening the airflow velocity with the silent wing.

\*Features above are only applicable to some of the models

# Metallic Series

Usage: Bathroom Toilet Office / Retail Store

20ASB / 25ASB / 30ASB  
20ASB 05 / 25ASB 05 / 30ASB 05

Dimension  
Unit : mm

### Metallic Structure

20 Series Installation 240 x 240mm

25 Series Installation 290 x 290mm

30 Series Installation 340 x 340mm



Model	A	B	C	D	E	F
20ASB/20ASB 05	200	300	312	240	50	90
25ASB/25ASB 05	250	350	362	290	45	90
30ASB/30ASB 05	300	400	412	340	45	90

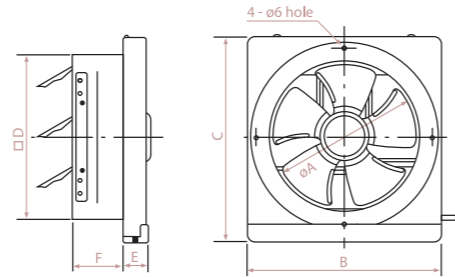

- Condenser motor with thermal cut-off
- Well-lubricated ball bearing for long life operation
- High performance propeller fan adopted
- Automatic shutter
- Powder painted metallic orifice, blade and oil cup
- Detachable oil cup
- Motor insulation Class E
- IP protection: IPX4 (outside)

KDK Company, Division of PES and Panasonic Ecology Systems Guangdong Co., Ltd. certifies that the Wall Mount Type Ventilation Fan – Metallic Series shown herein are licensed to bear the AMCA Seal. The ratings shown are based on tests and procedures performed in accordance with AMCA Publication 211 and AMCA Publication 311 and comply with the requirements of the AMCA Certified Ratings Program.

### Specification

Model	Voltage [V]	Frequency [Hz]	CFM / SONE AT STATIC Pressure (ps-inches of H <sub>2</sub> O)			RPM	Watts* FOR AMCA	Watts** FOR IEC
			Inches of H <sub>2</sub> O	0	0.025			
20ASB	220	60	CFM	330	259	183	25.5	21.5
	240	50	Sones	1.7	1.9	3.9		
20ASB 05	240	50	CFM	296	198	151	22.4	19.5
	240	50	Sones	1.5	1.7	3.2		
25ASB	220	60	CFM	296	198	151	35.5	30.5
	240	50	Sones	1.5	1.7	3.2		
25ASB 05	240	50	CFM	522	414	240	35.1	29.5
	240	50	Sones	1.9	1.6	2.2		
30ASB	220	60	CFM	486	434	314	39.8	34.5
	240	50	Sones	2.0	2.0	2.4		
30ASB 05	240	50	CFM	637	400	85	38.1	34
	240	50	Sones	2.0	2.7	2.2		
30ASB 05	240	50	CFM	706	620	498	38.1	34
	240	50	Sones	2.9	2.3	2.2		

Performance certified is for installation type A: Free inlet, Free outlet with partition. Performance ratings include the effects of a backdraft damper. The speed (RPM) and Watts rating shown are at the static pressure of 0 inch of H<sub>2</sub>O. The sound ratings shown are loudness values in fan sones at 5 ft. (1.5m) in a hemispherical free field calculated per AMCA International Standard 301. Values shown are for installation type A: Free inlet hemispherical sone levels.

\*the Watts rating is only for AMCA test method and it is at the static pressure of 0 inch of H<sub>2</sub>O.

\*\*the Watts rating is only for IEC test method and the AMCA Certified Ratings Seal does not apply to IEC test method watts.

### Installation

Outdoor hood  
Body  
Wooden frame  
Body  
Motor  
Orifice  
Oil catcher  
Blade assembly  
Spinner  
Power cord  
Knurled thumbscrew  
Mounting screw (Accessories) 4 pos.

Model No.	A	B	C	D	E	J	K
20ASB	300	312	240	50	90	250	200
20ASB 05	300	312	240	50	90	250	200
25ASB	350	362	290	45	90	300	250
25ASB 05	350	362	290	45	90	300	250
30ASB	400	412	340	45	90	350	300
30ASB 05	400	412	340	45	90	350	300

# Automatic Shutter Series

Usage: Bathroom Toilet Office / Retail Store

15AAQ1

Dimension  
Unit : mm

### Metallic Structure

Orifice Equipped with Oil Cup

Installation 170 x 170mm



- Condenser motor with thermal cut-off
- Well-lubricated ball bearing for long life operation
- High performance propeller fan adopted
- Automatic shutter with plastic cushions
- Orifice equipped with oil cup
- Motor insulation Class E
- IP protection: IPX4 (outside)

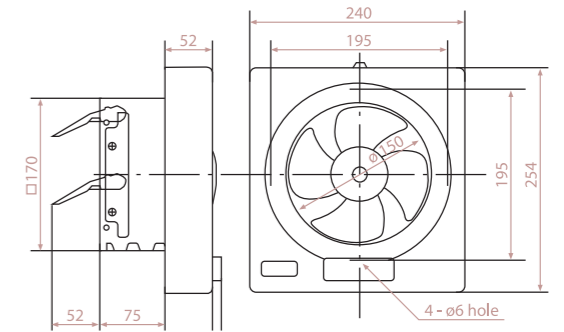

KDK Company, Division of PES and Panasonic Ecology Systems Guangdong Co., Ltd. certifies that the Wall Mount Type Ventilation Fan – Automatic Shutter Series shown herein are licensed to bear the AMCA Seal. The ratings shown are based on tests and procedures performed in accordance with AMCA Publication 211 and AMCA Publication 311 and comply with the requirements of the AMCA Certified Ratings Program.

### Specification

Model	Voltage [V]	Frequency [Hz]	CFM/SONE AT STATIC Pressure (ps-inches of H <sub>2</sub> O)			RPM	Watts* FOR AMCA	Watts** FOR IEC
			inches of H <sub>2</sub> O	0	0.025			
15AAQ1	220	60	CFM	157	122	65	20.6	19
	240	50	Sones	2.5	1.9	2.3		
15AAQ1	240	50	CFM	154	120	63	20.1	19
	240	50	Sones	1.7	1.4	2.1		

Performance certified is for installation type A: Free inlet, Free outlet with partition. Performance ratings include the effects of a backdraft damper. The speed (RPM) and Watts rating shown are at the static pressure of 0 inch of H<sub>2</sub>O. The sound ratings shown are loudness values in fan sones at 5 ft. (1.5m) in a hemispherical free field calculated per AMCA International Standard 301. Values shown are for installation type A: Free inlet hemispherical sone levels.

\*the Watts rating is only for AMCA test method and it is at the static pressure of 0 inch of H<sub>2</sub>O.

\*\*the Watts rating is only for IEC test method and the AMCA Certified Ratings Seal does not apply to IEC test method watts.

### Installation

Outdoor hood  
Body  
Wooden frame  
Body  
Motor  
Orifice  
Blade assembly  
Spinner  
Washer (Accessories)  
Mounting screw (Accessories)  
Power cord

# Automatic Shutter Series

Usage: Bathroom Toilet Office / Retail Store

## 20AUA / 25AUA / 30AUA

Dimension  
Unit : mm

- Silent Stream Fan
- Flat Surface Design
- Automatic Shutter

Model	A	B	C	D	E	F	G
20AUA	223	302	302	240	30	90	85
25AUA	273	352	352	290	32	90	67
30AUA	317	402	402	340	32	90	83

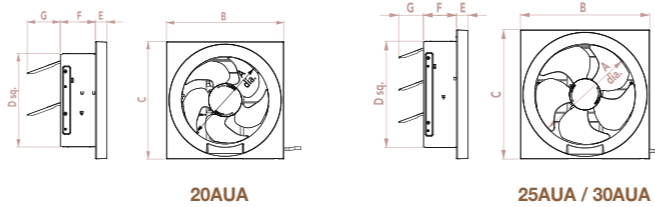

- Flat surface design
- Silent stream fan
- Half pitch condenser motor with thermal cut-off
- Well-lubricated ball bearing for long life operation
- Automatic shutter
- Motor insulation Class B
- IP protection: IPX4 (outside)

KDK Company, Division of PES and Panasonic Electric Works Vietnam Co., Ltd. certify that the Wall Mount Type Ventilation Fan – Automatic Shutter Series shown herein are licensed to bear the AMCA Seal. The ratings shown are based on tests and procedures performed in accordance with AMCA Publication 211 and AMCA Publication 311 and comply with the requirements of the AMCA Certified Ratings Program.

### Specification

Model	Voltage [V]	Frequency [Hz]	CFM / SONE AT STATIC Pressure (ps-inches of H <sub>2</sub> O)				RPM	Watts* FOR AMCA	Watts** FOR IEC	
			Inches of H <sub>2</sub> O	0	0.02	0.04				0.06
20AUA	220	60	CFM	370	328	274	227	1,430	23.5	22
			Sones	2.1	2.1	2.2	2.5			
25AUA	240	50	CFM	339	295	257	200	1,303	23	21.5
			Sones	2.0	2.1	2.0	4.5			
25AUA	220	60	CFM	542	504	460	361	1,387	33.2	31
			Sones	2.4	2.3	1.9	2.5			
30AUA	240	50	CFM	542	493	443	394	1,252	31	29
			Sones	3.6	3.2	3.0	3.1			
30AUA	220	60	CFM	655	567	456	242	938	35.3	33
			Sones	2.0	1.6	1.9	2.4			
30AUA	240	50	CFM	696	580	491	340	964	34.8	32.5
			Sones	2.0	1.8	1.6	2.2			

Performance certified is for installation type A: Free inlet, Free outlet with partition. Performance ratings include the effects of a backdraft shutter for Model AUA. The speed (RPM) and Watts rating shown are at the static pressure of 0 inch of H<sub>2</sub>O. The sound ratings shown are loudness values in fan sones at 5 ft. (1.5m) in a hemispherical free field calculated per AMCA International Standard 301. Values shown are for installation type A: Free inlet hemispherical sone levels.  
\*the Watts rating is only for AMCA test method and it is at the static pressure of 0 inch of H<sub>2</sub>O.  
\*\*the Watts rating is only for IEC test method.

### Wiring Diagram

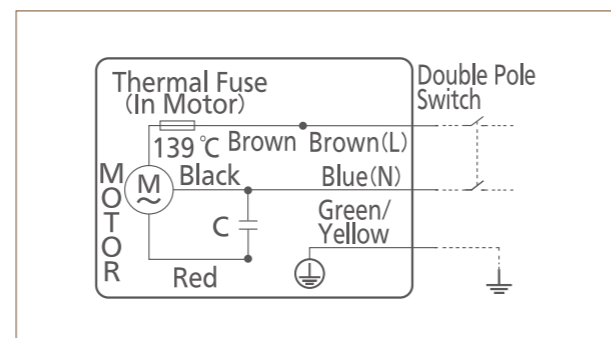

# Automatic Shutter Series

Usage: Bathroom Toilet Office / Retail Store

## 20AUH / 25AUH / 30AUH 11

Dimension  
Unit : mm

- Advanced Blade Design
- Automatic Shutter
- Single Speed

Model	A	B	C	D	E	F	G	H
20AUH	200	306	260	302	240	52	90	80
25AUH	250	356	310	352	290	38	90	63
30AUH 11	300	406	360	402	340	38	90	78

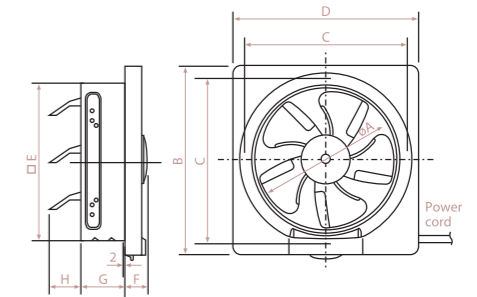

- Half pitch condenser motor with thermal cut-off
- Well-lubricated ball bearing for long life operation
- Propeller fan incorporated with advanced blade design (except 30AUH 11)
- Automatic shutter
- Motor insulation Class E
- IP protection: IPX4 (outside)

KDK Company, Division of PES and Panasonic Ecology Systems Guangdong Co., Ltd. certifies that the Wall Mount Type Ventilation Fan – Automatic Shutter Series shown herein are licensed to bear the AMCA Seal. The ratings shown are based on tests and procedures performed in accordance with AMCA Publication 211 and AMCA Publication 311 and comply with the requirements of the AMCA Certified Ratings Program.

### Specification

Model	Voltage [V]	Frequency [Hz]	CFM/SONE AT STATIC Pressure (ps-inches of H <sub>2</sub> O)				RPM	Watts* FOR AMCA	Watts** FOR IEC
			Inches of H <sub>2</sub> O	0	0.025	0.05			
20AUH	220	60	CFM	355	314	196	1,410	32.4	28.5
Sones	2.5	2.5	1.7						
25AUH	220	60	CFM	514	426	290	1,200	37.8	33
Sones	1.8	1.5	1.8						
30AUH 11	240	60	CFM	572	453	235	856	37.0	33
Sones	1.0	1.7	2.6						

Performance certified is for installation type A: Free inlet, Free outlet with partition. Performance ratings include the effects of a backdraft damper. The speed (RPM) and Watts rating shown are at the static pressure of 0 inch of H<sub>2</sub>O. The sound ratings shown are loudness values in fan sones at 5 ft. (1.5m) in a hemispherical free field calculated per AMCA International Standard 301. Values shown are for installation type A: Free inlet hemispherical sone levels.  
\*the Watts rating is only for AMCA test method and it is at the static pressure of 0 inch of H<sub>2</sub>O.  
\*\*the Watts rating is only for IEC test method and the AMCA Certified Ratings Seal does not apply to IEC test method watts.

### Wiring Diagram

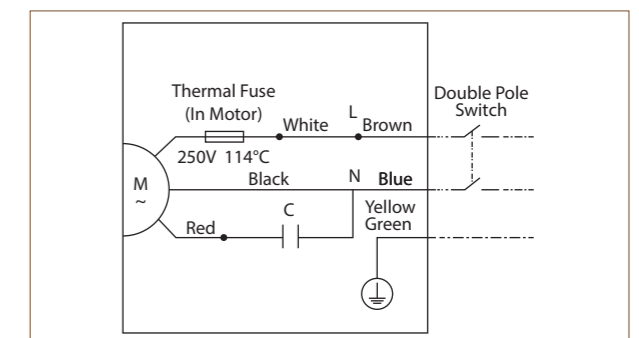

# Automatic Shutter Louver Series

Usage: Bathroom Toilet Office / Retail Store

## 20ALA / 25ALA / 30ALA

### Dimension

Unit : mm

Louver for Safety Protection

Silent Stream Fan

Automatic Shutter

Model	A	B	C	D	E	F	G
20ALA	223	302	302	240	60	90	85
25ALA	273	352	352	290	62	90	67
30ALA	317	402	402	340	62	90	83

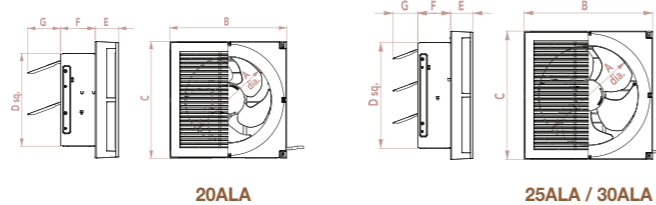

- Slim louver design
- Silent stream fan
- Half pitch condenser motor with thermal cut-off
- Well-lubricated ball bearing for long life operation
- Automatic shutter
- Motor insulation Class B
- IP protection: IPX4 (outside)

KDK Company, Division of PES and Panasonic Electric Works Vietnam Co., Ltd. certify that the Wall Mount Type Ventilation Fan – Automatic Shutter Series shown herein are licensed to bear the AMCA Seal. The ratings shown are based on tests and procedures performed in accordance with AMCA Publication 211 and AMCA Publication 311 and comply with the requirements of the AMCA Certified Ratings Program.

### Specification

Model	Voltage [V]	Frequency [Hz]	CFM / SONE AT STATIC Pressure (ps-inches of H <sub>2</sub> O)				RPM	Watts* FOR AMCA	Watts** FOR IEC	
			Inches of H <sub>2</sub> O	0	0.02	0.04				0.06
20ALA	220	60	CFM	334	296	256	197	1,398	23.5	22
			Sones	2.8	2.7	3.1	3.9			
25ALA	240	50	CFM	301	274	234	175	1,278	23	21.5
			Sones	2.5	2.5	2.7	2.8			
25ALA	220	60	CFM	471	411	350	250	1,224	33.2	31
			Sones	3.4	3.2	2.9	3.0			
30ALA	240	50	CFM	482	438	389	328	1,217	32.1	30
			Sones	4.2	4.1	3.8	3.8			
30ALA	220	60	CFM	510	446	372	219	867	35.3	33
			Sones	2.5	2.0	3.0	2.1			
30ALA	240	50	CFM	571	494	411	263	896	35.3	32.5
			Sones	3.1	2.6	2.5	3.3			

Performance certified is for installation type A: Free inlet, Free outlet with partition. Performance ratings include the effects of inlet grille and backdraft shutter for Model ALA. The speed (RPM) and Watts rating shown are at the static pressure of 0 inch of H<sub>2</sub>O. The sound ratings shown are loudness values in fan sones at 5 ft. (1.5m) in a hemispherical free field calculated per AMCA International Standard 301. Values shown are for installation type A: Free inlet hemispherical sone levels.

\*the Watts rating is only for AMCA test method and it is at the static pressure of 0 inch of H<sub>2</sub>O.

\*\*the Watts rating is only for IEC test method.

### Wiring Diagram

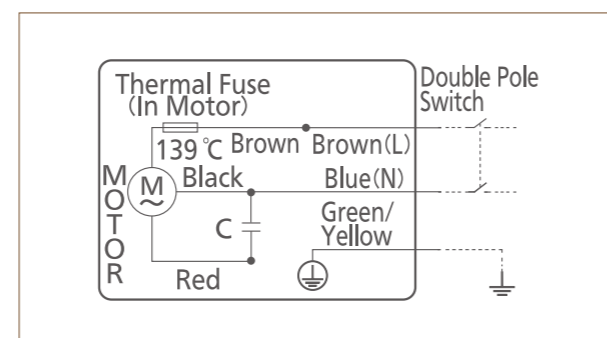

# Automatic Shutter Louver Series

Usage: Bathroom Toilet Office / Retail Store

## 20ALH / 25ALH / 30ALF 11

### Dimension

Unit : mm

Louver for Safety Protection

Advanced Blade Design

Single Speed

Model	A	B	C	D	E	F	G	H
20ALH	200	306	260	302	240	68	90	80
25ALH	250	356	310	352	290	63	90	63
30ALF 11	300	406	360	402	340	63	90	78

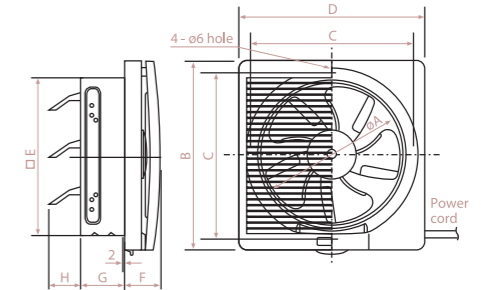

- Half pitch condenser motor with thermal cut-off
- Well-lubricated ball bearing for long life operation
- Propeller fan incorporated with advanced blade design (except 30ALF 11)
- Automatic shutter
- Motor insulation Class E
- IP protection: IPX4 (outside)

KDK Company, Division of PES and Panasonic Ecology Systems Guangdong Co., Ltd. certifies that the Wall Mount Type Ventilation Fan – Automatic Shutter Series shown herein are licensed to bear the AMCA Seal. The ratings shown are based on tests and procedures performed in accordance with AMCA Publication 211 and AMCA Publication 311 and comply with the requirements of the AMCA Certified Ratings Program.

### Specification

Model	Voltage [V]	Frequency [Hz]	CFM/SONE AT STATIC Pressure (ps-inches of H <sub>2</sub> O)				RPM	Watts* FOR AMCA	Watts** FOR IEC
			Inches of H <sub>2</sub> O	0	0.025	0.05			
20ALH	220	60	CFM	328	280	170	1,385	32.8	28.5
Sones	3.5	3.2	3.4						
25ALH	220	60	CFM	420	372	232	1,097	37.5	33
Sones	2.7	2.7	4.6						
30ALF 11	220	60	CFM	447	288	154	746	37.1	33
Sones	2.0	2.7	2.2						

Performance certified is for installation type A: Free inlet, Free outlet with partition. Performance ratings include the effects of an inlet grille and backdraft damper. The speed (RPM) and Watts rating shown are at the static pressure of 0 inch of H<sub>2</sub>O. The sound ratings shown are loudness values in fan sones at 5 ft. (1.5m) in a hemispherical free field calculated per AMCA International Standard 301. Values shown are for installation type A: Free inlet hemispherical sone levels.

\*the Watts rating is only for AMCA test method and it is at the static pressure of 0 inch of H<sub>2</sub>O.

\*\*the Watts rating is only for IEC test method and the AMCA Certified Ratings Seal does not apply to IEC test method watts.

### Wiring Diagram

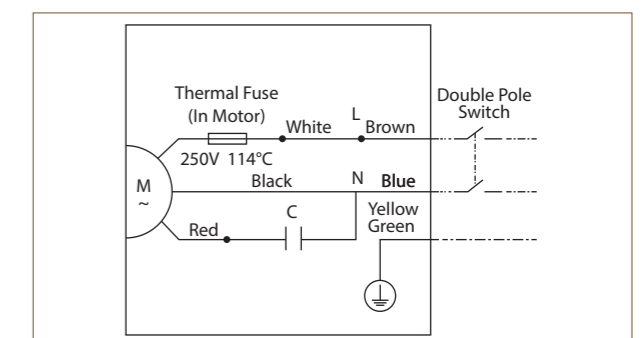

# Automatic Shutter Louver Series

Usage: Bathroom Toilet Office / Retail Store

## 10BAQ1

Powerful Sirocco Fan

Louver for Safety Protection

Long Life Operation



- Condenser motor with thermal cut-off
- Lubricated sintered brush for long life operation
- Highly efficient sirocco fan
- Blind shutter louver to enhance privacy and safety
- Plastic frame, blade and louver
- Motor insulation Class E
- IP protection: IPX4 (outside)

### Dimension

Unit : mm

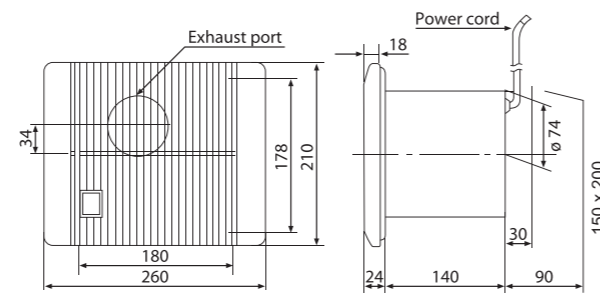

### Specification

Model	Voltage [V]	Frequency [Hz]	Air Volume		Consumption [W]	RPM	Noise [dB(A)]	Weight [kg]	Installation Space [mm]
			[CMH]	[CFM]					
10BAQ1	220	50	76.3	45	15	1,250	40.1	1.7	155 x 205
		60	72.9	43	17	1,200	39.8		
	230	50	80.3	47	16	1,300	41.2		
		240	50	84.9	50	17.5	1,385		

Note: RPM data is for reference only, values may vary subject to different conditions

Test Condition

- Air volume, electric characteristic and noise are specified at the static pressure of 0 Pa
- The values of noise level is A weighted average sound pressure level, the mean values are measured by our company, within +3 to -7 dB tolerance
- The values of noise level are measured at 1 m apart from the side of fan body when ducts are connected on outlet side
- The values of air volume are the mid-points of results measured by our company, within ±10% tolerance

### Installation

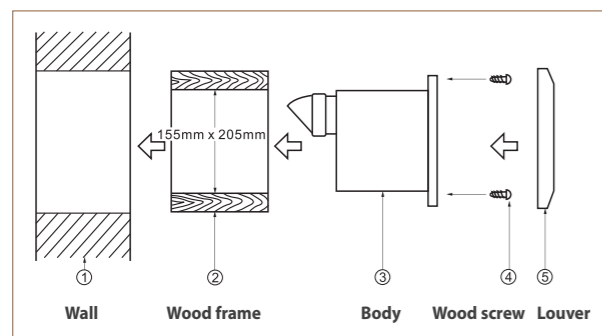

### Wiring Diagram

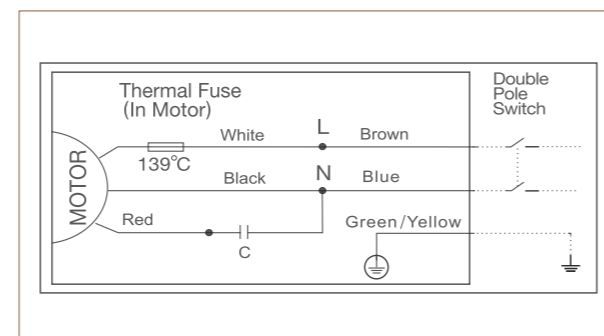

# Feature of Bathroom Series

## Easy Installation - Pipe Hood Series

With the supplied accessories, it only takes a few steps to complete the installation.

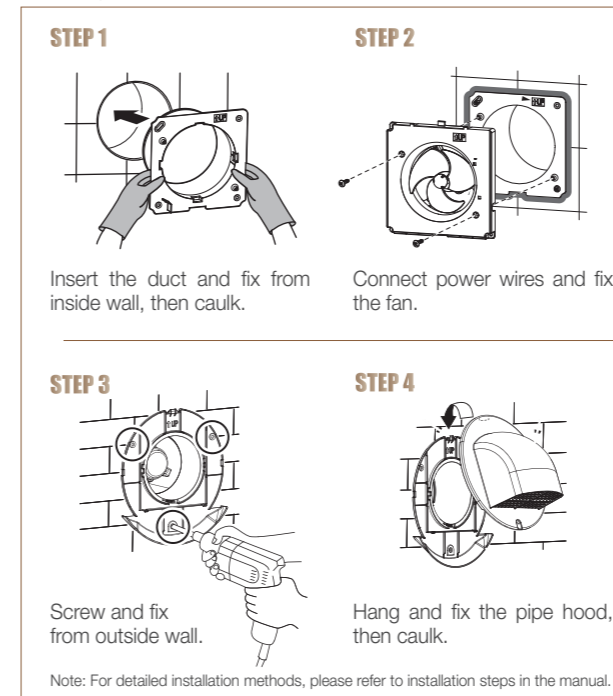

## All Accessories Included

The product comes bundled with all required accessories. It conveniently saves the hassle of seeking necessary accessories around.



## Trace-Prevention

Pipe Hood Series Only

When it rains, rainwater dripping along the side of pipe hood may cause trace marks on wall. The exclusively designed duct ring catches and drains the water away to avoid forming trace marks.

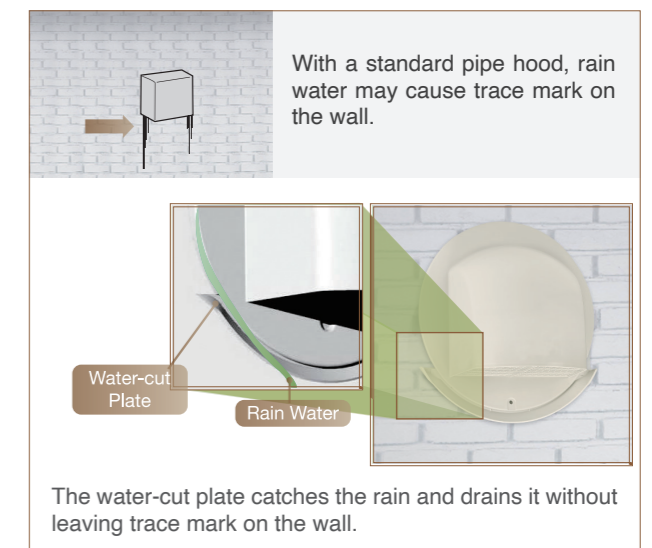

## Back Draft Shutter

Shutter Series (For Vertical Shaft) only

Wind from outside may come indoor through the duct when the fan is not operating. The back draft shutter is designed to cover the duct hole to block wind and water.

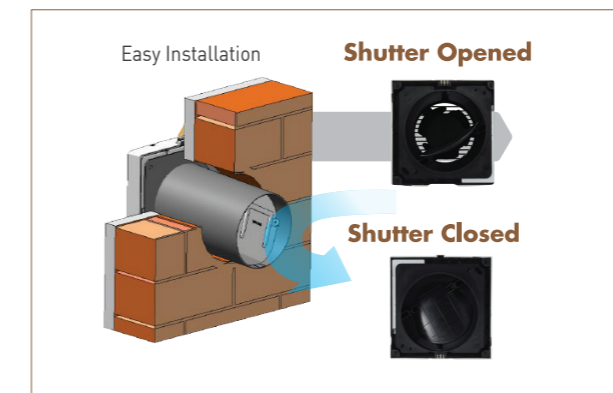

Bathroom

Toilet

Shower Room

# Bathroom Series

Usage: Bathroom Toilet

## 10EGKB / 15EGKB

Advanced Blade Design

Easy Installation

Pipe Hood Equipped



- Pipe hood series
- Powerful exhaust of excessive moisture and odour
- Prevent rain water trace by water-cut plate at duct ring
- Half pitch condenser motor with thermal cut-off
- Well-lubricated ball bearing for long life operation
- Motor insulation Class E
- IP protection: IPX4 (outside)

### Specification

Model	Voltage [V]	Frequency [Hz]	Air Volume [CMH]	Consumption [W]	RPM	Noise [dB(A)]	Weight [kg]	Wall Installation		Ceiling Installation
								Hole Size [mm]	Wall Thickness [mm]	Hole Size [mm]
10EGKB	220	50	76	4.3	2,660	33	1.0	Ø130~140	100~150	Ø130~140
	230	50	77	4.6	2,675	33				
	240	50	77	5.0	2,690	33				
15EGKB	220	50	162	5.7	2,265	36	1.3	Ø175~185	100~150	Ø175~185
	230	50	165	6.1	2,330	37				
	240	50	165	6.5	2,390	37				

Note: RPM data is for reference only, values may vary subject to different conditions

Test Condition

- Air volume, electric characteristic and noise are specified at the static pressure of 0 Pa
- The values of noise level is A weighted average sound pressure level, the mean values are measured by our company, within +3 to -7 dB tolerance
- The values of noise level are measured at 1 m apart from the side of fan body when ducts are connected on outlet side
- The values of air volume are the mid-points of results measured by our company, within ±10% tolerance

### Wiring Diagram

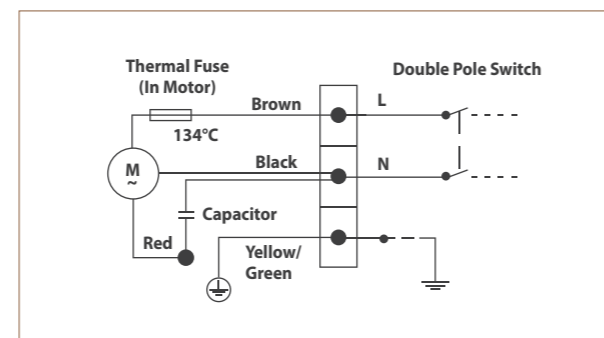

# Bathroom Series

Usage: Bathroom Toilet

## 10EGSB / 15EGSB

Advanced Blade Design

Automatic Shutter

Shutter Equipped



- Shutter series (for vertical shaft)
- Powerful exhaust of excessive moisture and odour
- Half pitch condenser motor with thermal cut-off
- Well-lubricated ball bearing for long life operation
- Motor insulation Class E
- IP protection: IPX4 (outside)

### Specification

Model	Voltage [V]	Frequency [Hz]	Air Volume [CMH]	Consumption [W]	RPM	Noise [dB(A)]	Weight [kg]	Wall Installation		Ceiling Installation
								Hole Size [mm]	Duct Space [mm]	Hole Size [mm]
10EGSB	220	50	76	4.3	2,665	35	0.8	Ø120-125	>205	Ø130~140
		60	87	4.7	3,140	37.5				
	230	50	77	4.6	2,670	35				
15EGSB	220	50	155	5.7	2,130	36	1.0	Ø165-170	>240	Ø175~185
		60	180	6.1	2,470	40				
	230	50	160	6.1	2,230	37				
	240	50	165	6.5	2,240	37				

Note: RPM data is for reference only, values may vary subject to different conditions

Test Condition

- Air volume, electric characteristic and noise are specified at the static pressure of 0 Pa
- The values of noise level is A weighted average sound pressure level, the mean values are measured by our company, within +3 to -7 dB tolerance
- The values of noise level are measured at 1 m apart from the side of fan body when ducts are connected on outlet side
- The values of air volume are the mid-points of results measured by our company, within ±10% tolerance

### Wiring Diagram

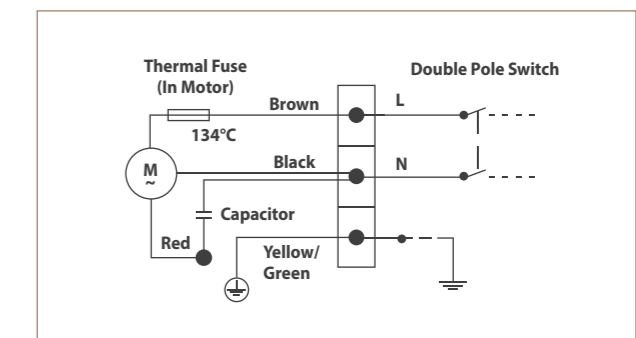

# Window Mount Type Ventilation Fan



24 Hours Ventilation



High Performance



Low-Noise



Durable



Scan for more information



Electric Shutter Series  
Able to maintain airtightness



Automatic Shutter Series  
Able to maintain airtightness



Cord-operated Shutter Series  
Can be easily installed in any glass window



# Features of Electric Shutter Series

## Rain proof and wind resistible



## Easy installation

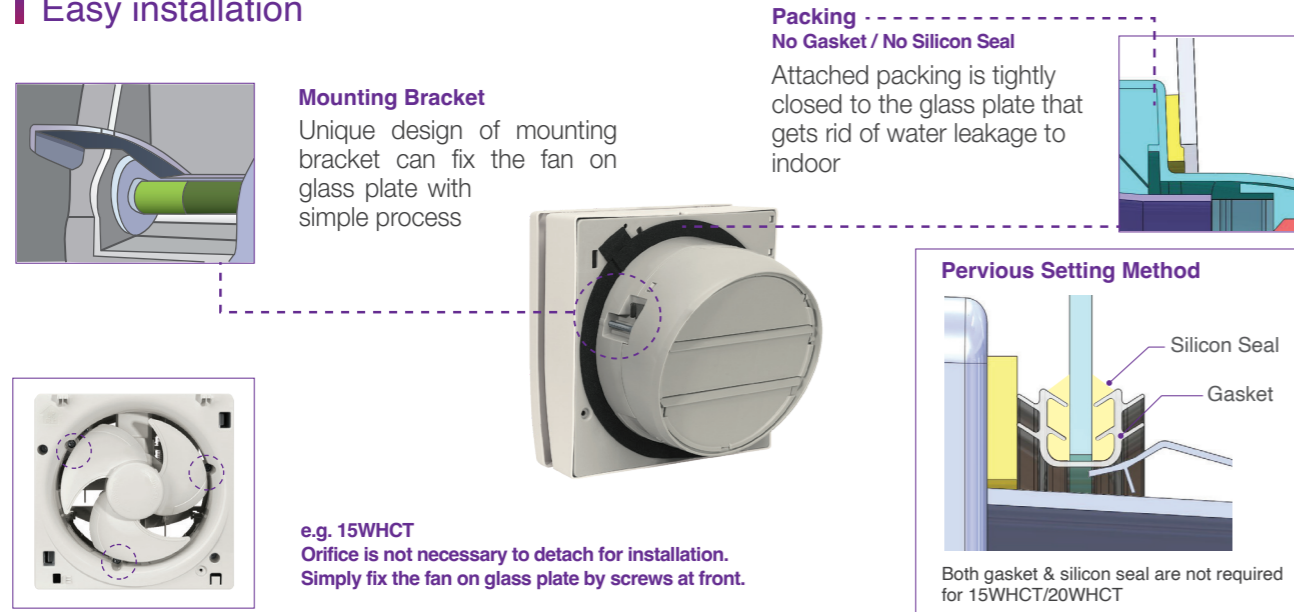

## High adaptability

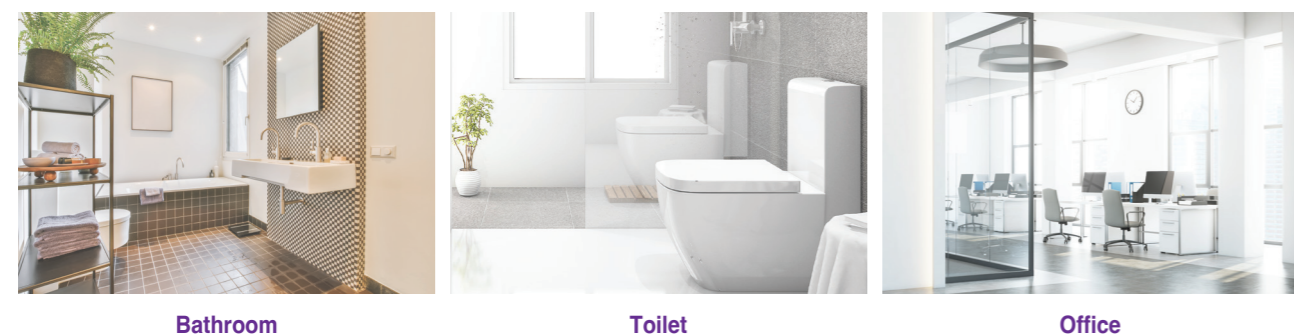
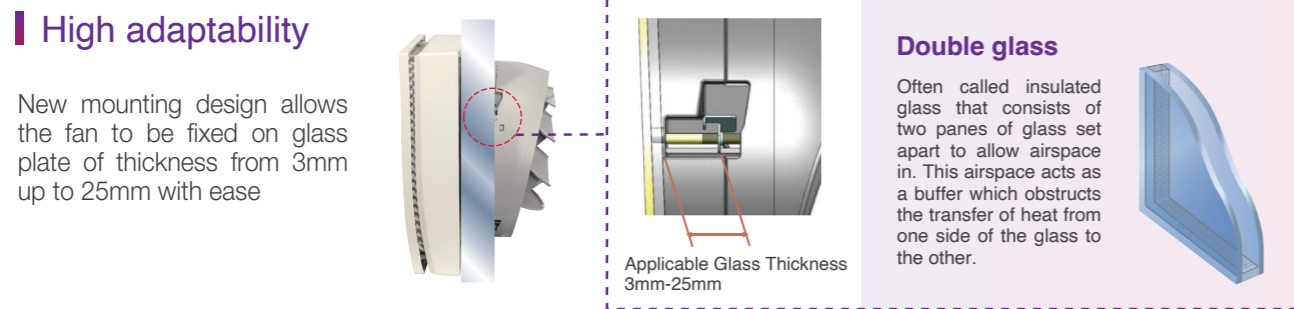

Bathroom

Toilet

Office

# Electric Shutter Series

Usage: Bathroom Toilet Office / Retail Store

## 15WHCT / 20WHCT

- Louver for Protection
- Rain proof and wind resistible
- Prevent Rain and Wind



### Dimension Unit : mm

Model	A	B	C	C'	D
15WHCT	224	182	117	111	72
20WHCT	288	243	120	117	74

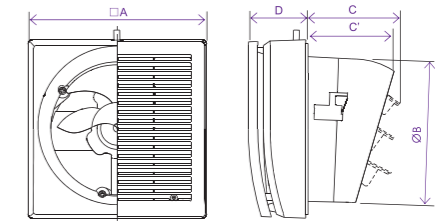

- Electrically operated shutter
- Advanced design hood structure to prevent rain and wind
- Suitable for window glass with thickness from 3mm to 25mm
- Simple and easy installation, no need of any silicon seal or gasket
- Motor insulation Class E
- IP protection: IPX4 (outside)

KDK Company, Division of PES and Panasonic Electric Works Vietnam Co., Ltd. certify that the window mount series models shown herein are licensed to bear the AMCA Seal. The ratings shown are based on tests and procedures performed in accordance with AMCA Publication 211 and AMCA Publication 311 and comply with the requirements of the AMCA Certified Ratings Program.

## Specification

Model	Voltage [V]	Frequency [Hz]	CFM/SONE AT STATIC Pressure (ps-inches of H <sub>2</sub> O)				RPM	Watts*	Watts**	
			inches of H <sub>2</sub> O	0	0.05	0.1		0.15	FOR AMCA	FOR IEC
15WHCT	220	60	CFM	127	94	63	31	2,440	14.6	13
			Sones	3.0	3.6	3.5	3.9			
20WHCT	220	60	CFM	250	188	127	78	1,517	24.4	22
			Sones	3	3.9	4.5	4.2			
20WHCT	240	50	CFM	230	147	103	53	1,333	23.4	22
			Sones	2.8	3.8	3.4	4			

Performance certified is for installation type A: Free inlet, Free outlet with partition. Performance ratings include the effects of inlet grille and shutter. The Speed (RPM) and Watts rating shown are at the static pressure of 0 inch of H<sub>2</sub>O. The sound ratings shown are loudness values in fan sones at 5 ft. (1.5m) in a hemispherical free field calculated per AMCA International Standard 301. Values shown are for installation type A: Free Inlet hemispherical sone levels.

\* the Watts rating is only for AMCA test method and it is at the static pressure of 0 inch of H<sub>2</sub>O.

\*\* the Watts rating is only for IEC test method and the AMCA Certified Ratings Seal does not apply to IEC test method watts.

## Installation Example

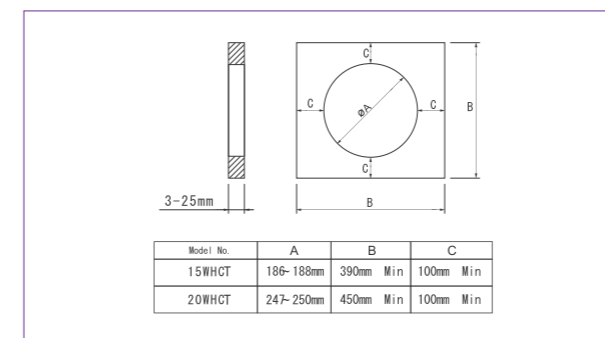

## Wiring Diagram

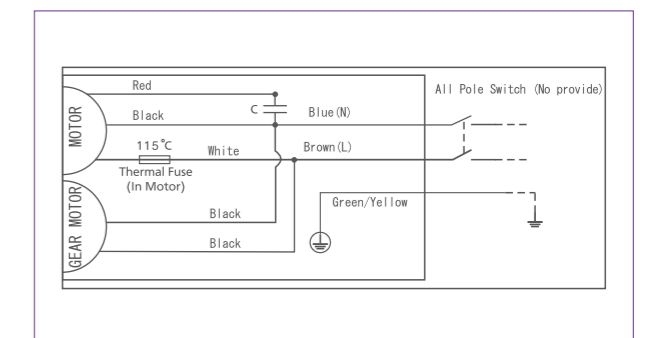

# Features of Automatic Shutter Series

## Auto Shutter

The backdraft shutters will be opened by air pressure during operation and closed automatically for air-tightness when the fan is switched off.



## Advanced Blade Design

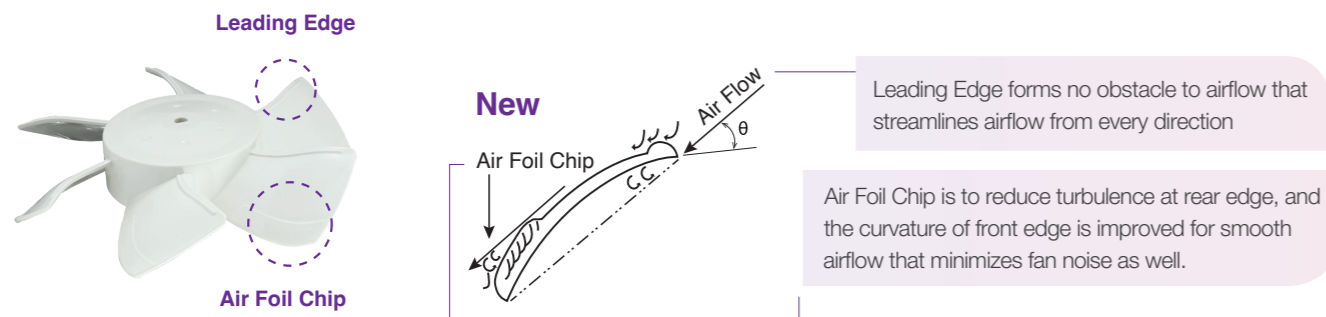

## Half pitch condenser motor with well-lubricated ball bearing

- Low power consumption (50% down VS previous model)
- Low noise level (6% down VS previous model)
- Long life up to 40,000 hours (1.5 time VS previous model)
- Comply with IPX4 (outside)



## Easy Maintenance

The blade can be detached by simply loosening the spinner, that facilitates the periodical maintenance.

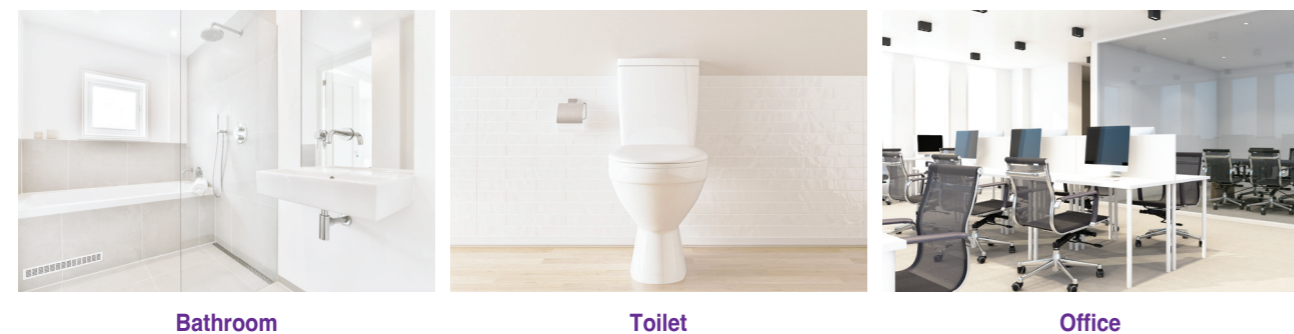
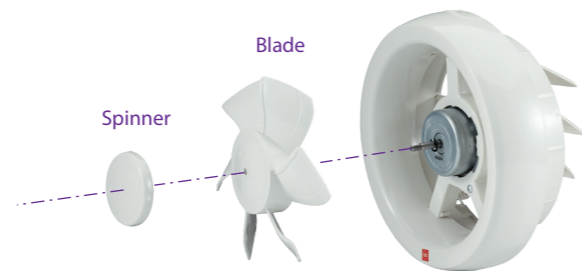

Bathroom

Toilet

Office

# Automatic Shutter Series

Usage: Bathroom Toilet Office / Retail Store

15WAA / 15WAAMN  
20WAA / 20WAAMN

Automatic Shutter

Advanced Blade Design

Easy Maintenance

## Dimension

Unit : mm

Model	A	B	C	D	E	F	G	H(MAX)
15WAA	150	212	100	47	53	38	175	(30)
20WAA	206	290	122	76	46	59	237	(36)

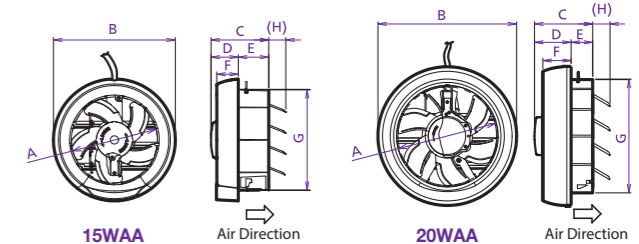

- Automatic shutter
- Half pitch condenser motor with thermal cut-off
- Well-lubricated ball bearing for long life operation
- Propeller fan incorporated with advanced blade design
- Removable blade for easy maintenance
- Motor insulation Class E
- IP protection: IPX4 (outside)

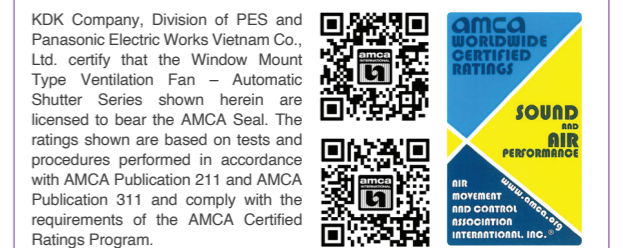

## Specification

Model	Voltage [V]	Frequency [Hz]	CFM/SONE AT STATIC Pressure (ps-inches of H <sub>2</sub> O)				RPM	Watts*	
			inches of H <sub>2</sub> O	0	0.02	0.04		0.06	FOR AMCA
15WAA 15WAAMN	220	60	CFM	124	109	91	79	2,021	19.6
			Sones	3.6	4.5	4.1	4		
20WAA 20WAAMN	220	60	CFM	250	147	124	94	1,385	18.4
			Sones	3	3.8	3.5	3.3		
15WAA 15WAAMN	240	50	CFM	127	109	93	78	2,062	18.2
			Sones	2.3	4.5	4.1	3.8		
20WAA 20WAAMN	240	50	CFM	230	153	141	131	1,375	18.6
			Sones	2.8	3.3	3.4	3.4		

Performance certified is for installation type A: Free inlet, Free outlet with partition. Performance ratings include the effects of backdraft shutter. The Speed (RPM) and Watts rating shown are at the static pressure of 0 inch of H<sub>2</sub>O. The sound ratings shown are loudness values in fan sones at 5 ft. (1.5m) in a hemispherical free field calculated per AMCA International Standard 301. Values shown are for installation type A: Free Inlet hemispherical sone levels.

\* the Watts rating is only for AMCA test method and it is at the static pressure of 0 inch of H<sub>2</sub>O.

\*\* the Watts rating is only for IEC test method and the AMCA Certified Ratings Seal does not apply to IEC test method watts.

## Installation Example

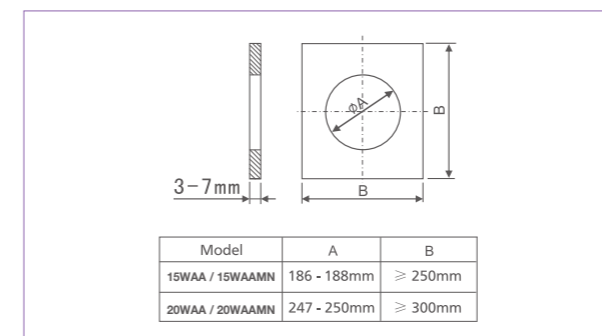

## Wiring Diagram

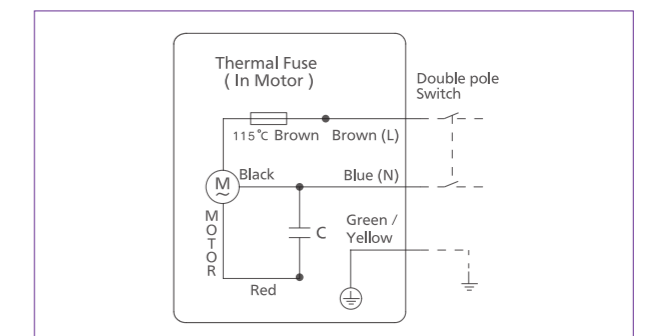

# Features of Cord-Operated Shutter Series

## Strengthened Shutter Structure



## Advanced Blade Design

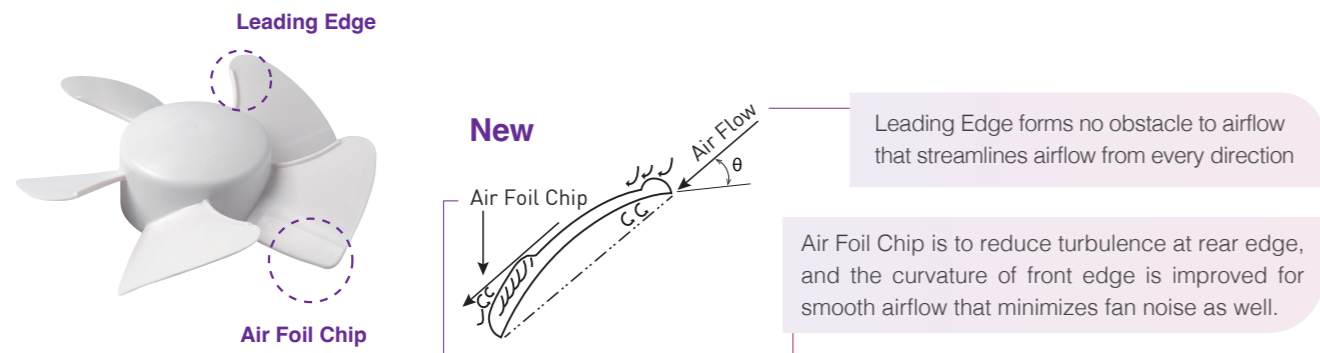

## Easy Maintenance

The blade can be detached by simply loosening the spinner, that facilitates the periodical maintenance.

## Half pitch condenser motor with well-lubricated ball bearing

- Low power consumption (50% down VS previous model)
- Low noise level (6% down VS previous model)
- Long life up to 40,000 hours (1.5 time VS previous model)
- Comply with IPX4 (outside)

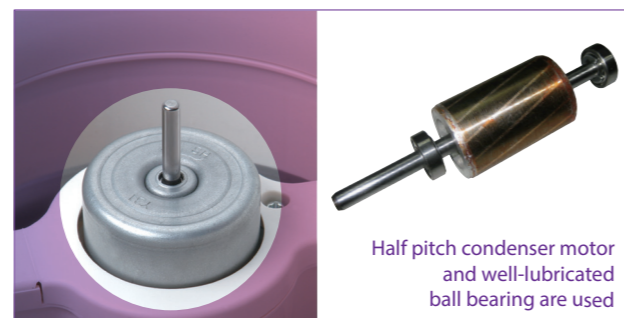

Bathroom



Toilet



Office

# Cord-Operated Shutter Series

Usage: Bathroom Toilet Office / Retail Store

15WUD / 15WUDMN  
20WUD / 20WUDMN

Cord-operated Shutter

Advanced Blade Design

Metallic Shutter Axis



Dimension  
Unit : mm

Model	A	B	C	D	E	F	G	H
15WUD	150	210	97	43	54	37	177	149
20WUD	200	271	98	36	62	36	237	201

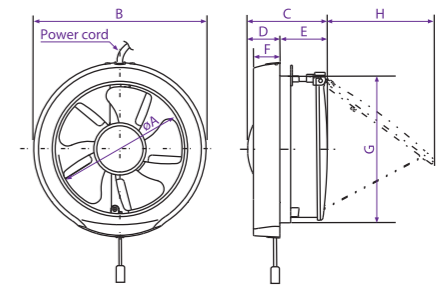

- Half pitch condenser motor with thermal cut-off
- Well-lubricated ball bearing for long life operation
- Propeller fan incorporated with advanced blade design
- Shutter operated by pull cord
- Metallic shutter axis
- Motor insulation Class E
- IP protection: IPX4 (outside)

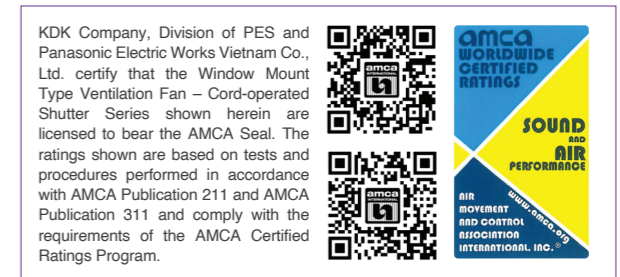

## Specification

Model	Voltage [V]	Frequency [Hz]	CFM/SONE AT STATIC Pressure (ps-inches of H <sub>2</sub> O)					RPM	Watts*	Watts**
			inches of H <sub>2</sub> O	0	0.01	0.02	0.03		FOR AMCA	FOR IEC
15WUD 15WUDMN	220	60	CFM	105	94	79	66	1,425	9.7	8.9
			Sones	0.9	0.9	2.2	2.4			
	240	50	CFM	124	115	104	94	1,722	10.3	9.5
			Sones	1.4	1.6	1.8	3.7			
			inches of H <sub>2</sub> O	0	0.02	0.03	0.04			
20WUD 20WUDMN	220	60	CFM	188	129	112	88	980	19.2	17.9
			Sones	0.8	1.2	1.8	1.4			
	240	50	CFM	221	168	141	118	1,096	18.5	17.2
			Sones	1.8	1.6	2.2	2.0			

Performance certified is for installation type A: Free inlet, Free outlet with partition. Performance ratings include the effects of backdraft shutter. The Speed (RPM) and Watts rating shown are at the static pressure of 0 inch of H<sub>2</sub>O. The sound ratings shown are loudness values in fan sones at 5 ft. (1.5m) in a hemispherical free field calculated per AMCA International Standard 301. Values shown are for installation type A: Free Inlet hemispherical sone levels.

\* the Watts rating is only for AMCA test method and it is at the static pressure of 0 inch of H<sub>2</sub>O.

\*\* the Watts rating is only for IEC test method and the AMCA Certified Ratings Seal does not apply to IEC test method watts.

## How to Turn On

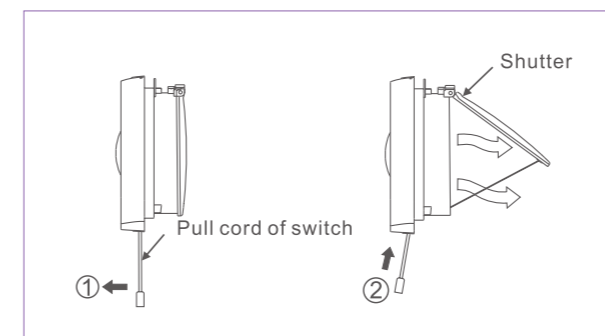

## How to Turn Off

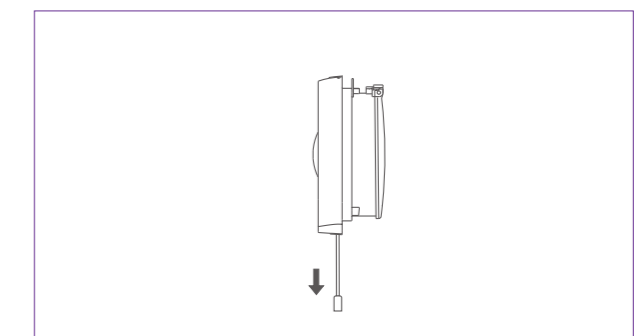

# Industrial Type Ventilation Fan



High Performance



Low-Noise



Durable

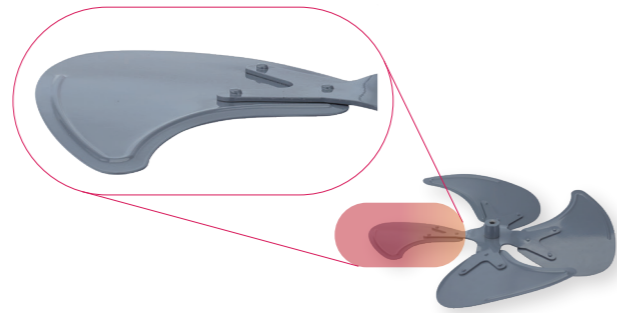

Fans with 3D Wave-shaped Cross Section Blade\*

\*The 3D wave-shaped blade only applicable to some of the models

# Shutter Series

Usage: Factory Warehouse Retail Store Commercial Kitchen

## 40KAQA

High Pressure

Rust Resistant

Shutter

## Dimension

Unit : mm

Model	A	B	C	D	E	F	G	H	I
40KAQA	510	480	215	40	55	434	10	126	130

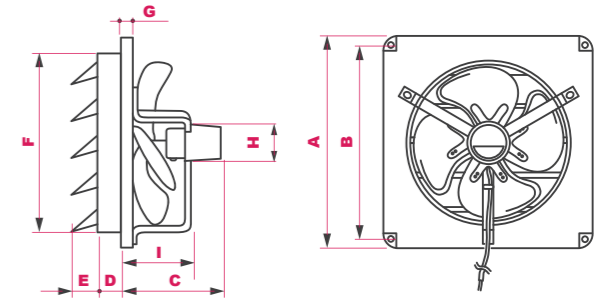

- With shutter
- Durable powder coating for rust resistance
- High performance condenser motor with thermal cut-off
- Operable at an ambient temperature range from -10°C to +50°C
- Motor insulation Class E
- IP protection: IPX4 (outside)

## Specification

Voltage [V]	Frequency [Hz]	Air Volume [CMH] [CFM]	Current [A]	Input [W]	Noise [dB(A)]	RPM	Weight [kg]	Installation Space W x L [mm]
220	50	1,880 1,105	0.260	47.0	51.0	1,230 ~ 1,370	6.4	444 x 444
230		1,920 1,130	0.270	52.0	51.0	1,250 ~ 1,390		
240		1,960 1,155	0.290	59.0	51.0	1,270 ~ 1,410		
230	60	2,130 1,254	0.310	67.0	52.5	1,400 ~ 1,540		

Note: RPM data is for reference only. Values may vary depending on different conditions.

1. The value of power consumption, air volume and noise are specified at the static pressure of 0 Pa.
2. The value of air volume is the mean value which is measured by our company.
3. The value of noise level is measured at 1m apart from the left, the right and the front of product, then get the average of three values.
4. The value of noise level is A weight average sound pressure level, the mean value is measured by our company.

## Performance Data

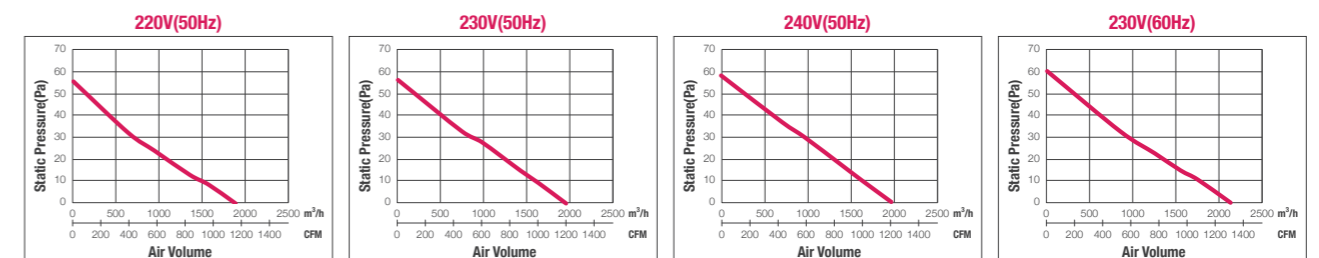

## Installation

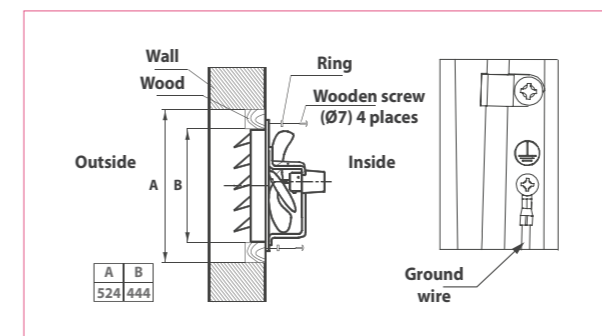

## Wiring Diagram

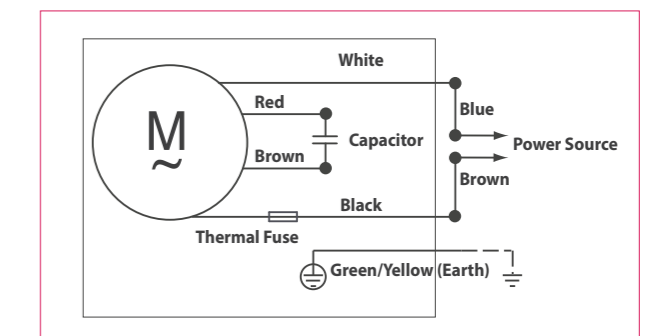

Scan for more information



# High Pressure Series

Usage: Factory Warehouse Retail Store Commercial Kitchen

## 25GSE / 30GSE / 35GSE

Dimension  
Unit : mm

Single Phase

Reversible

Optional Shutter



Model	A	B	C	D	E	F	G	H
25GSE	327	298	165	-	171	10	-	250
30GSE	378	349	210	-	200	10	-	300
35GSE	467	434	250	-	235	12	-	350

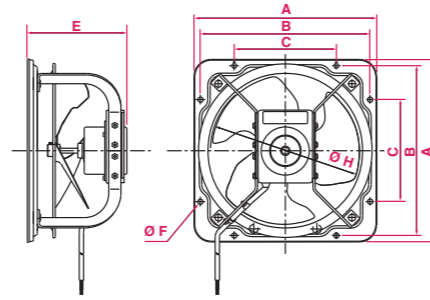

- Bell mouth construction with distinctive wave-shaped blade
- Durable powder coating
- Operable at an ambient temperature range from -10°C to +50°C
- Possible to install horizontally or vertically
- Motor insulation Class E
- IP protection: IPX4 (outside)

KDK Company, Division of PES and Panasonic Ecology Systems Guangdong Co., Ltd. certify that the Industrial Ventilation Fan - High Pressure Series shown herein are licensed to bear the AMCA Seal. The ratings shown are based on tests and procedures performed in accordance with AMCA Publication 211 and AMCA Publication 311 and comply with the requirements of the AMCA Certified Ratings Program.



### Specification

Model	Voltage [V]	Frequency [Hz]	CFM / SONE AT STATIC Pressure (ps-inches of H <sub>2</sub> O)								RPM	Watts* FOR AMCA	Watts** FOR IEC
			Inches of H <sub>2</sub> O	0	0.05	0.075	0.1	0.125	0.25	0.375			
25GSE	220	60	CFM	788	742	715	686	647	-	-	1,570	61	57
			Sones	4.9	4.7	4.5	4.5	4.6	-	-			
30GSE	240	50	CFM	701	657	633	600	585	187	-	1,400	48	44
			Sones	3.8	3.6	3.6	3.5	3.6	8.6	-			
30GSE	220	60	CFM	1,308	1,247	1,217	1,184	1,153	772	-	1,460	129	119
			Sones	9.0	9.0	9.1	9.0	9.1	9.4	-			
30GSE	240	50	CFM	1,177	1,119	1,090	1,058	1,026	561	243	1,315	106	98
			Sones	5.5	5.5	5.6	5.6	5.8	11.1	12.0			
35GSE	220	60	CFM	1,850	1,788	1,752	1,712	1,669	1,456	600	1,640	178	161
			Sones	11.9	11.6	12.0	12.4	13.6	14.6	13.4			
35GSE	240	50	CFM	1,615	1,548	1,506	1,458	1,411	1,147	390	1,435	130	122
			Sones	8.6	8.2	8.2	8.0	8.0	12.6	13.4			

Performance certified is for installation type A: Free inlet, Free outlet with partition. Performance ratings do not include the effects of appurtenances (accessories). The sound ratings shown are loudness values in fan sones at 5 ft. (1.5m) in a hemispherical free field calculated per AMCA International Standard 301. Values shown are for installation type A: Free inlet hemispherical sone levels. Speed (RPM) shown is nominal. Performance is based on actual speed of test.

\*the Watts rating is only for AMCA test method and it is at the statistic pressure of 0 inch of H<sub>2</sub>O.

\*\*the Watts rating is only for IEC test method.

### Wiring Diagram

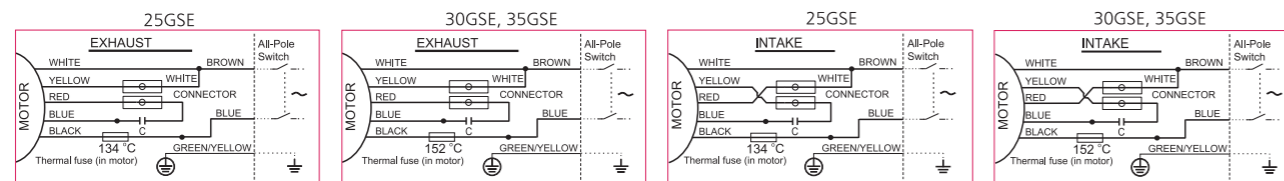

# High Pressure Series

Usage: Factory Warehouse Retail Store Commercial Kitchen

## 40GSE

Dimension  
Unit : mm

Single Phase

Reversible

Optional Shutter



Model	A	B	C	D	E	F	G	H
40GSE	518	485	280	460	274	12	12	400

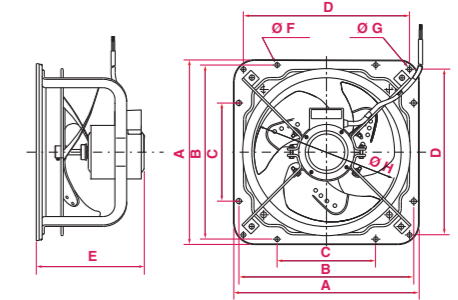

- Bell mouth construction with distinctive wave-shaped blade
- Durable powder coating
- Operable at an ambient temperature range from -10°C to +50°C
- Possible to install horizontally or vertically
- Motor insulation Class B
- IP protection: IPX4 (outside)

KDK Company, Division of PES and Panasonic Ecology Systems Guangdong Co., Ltd. certify that the Industrial Ventilation Fan - High Pressure Series shown herein are licensed to bear the AMCA Seal. The ratings shown are based on tests and procedures performed in accordance with AMCA Publication 211 and AMCA Publication 311 and comply with the requirements of the AMCA Certified Ratings Program.



### Specification

Model	Voltage [V]	Frequency [Hz]	CFM / SONE AT STATIC Pressure (ps-inches of H <sub>2</sub> O)								RPM	Watts* FOR AMCA	Watts** FOR IEC
			Inches of H <sub>2</sub> O	0	0.05	0.075	0.1	0.125	0.25	0.375			
40GSE	220	60	CFM	2,677	2,581	2,535	2,488	2,440	2,170	2,050	1,550	294	270
			Sones	20.0	20.0	19.7	19.4	19.3	18.9	19.9			
40GSE	240	50	CFM	2,135	2,067	2,035	2,000	1,965	1,800	1,480	1,440	164	151
			Sones	9.0	8.5	8.7	8.7	8.7	13.0	14.2			

Performance certified is for installation type A: Free inlet, Free outlet with partition. Performance ratings do not include the effects of appurtenances (accessories). The sound ratings shown are loudness values in fan sones at 5 ft. (1.5m) in a hemispherical free field calculated per AMCA International Standard 301. Values shown are for installation type A: Free inlet hemispherical sone levels. Speed (RPM) shown is nominal. Performance is based on actual speed of test.

\*the Watts rating is only for AMCA test method and it is at the static pressure of 0 inch of H<sub>2</sub>O.

\*\*the Watts rating is only for IEC test method and the AMCA Certified Ratings Seal does not apply to IEC test method watts.

### Wiring Diagram

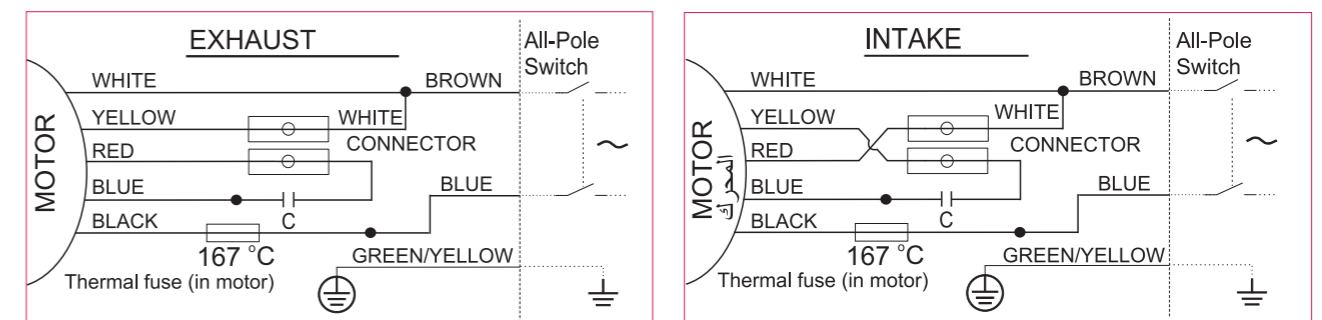

# High Pressure Series

Usage: Factory Warehouse Retail Store Commercial Kitchen

## 45GSC / 50GSC / 60GSC

Single Phase

Reversible

Optional Shutter

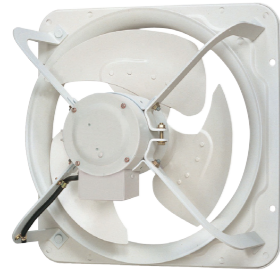

Model	A	B	C	D	E	F	G
45GSC	450	570	540	-	320	297	12
50GSC	500	659	620	560	355	315	15
60GSC	620	760	720	650	400	320	15

Dimension  
Unit : mm

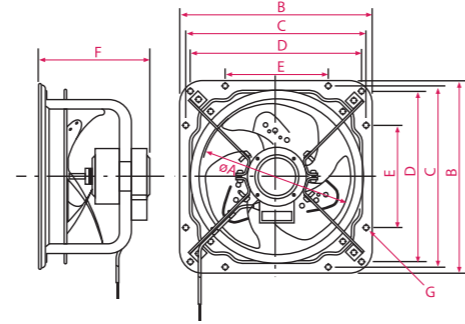

- Bell mouth construction with distinctive wave-shaped blade
- Durable powder coating
- Operable at an ambient temperature range from -10°C to +50°C
- Possible to install horizontally or vertically
- Motor insulation Class E

KDK Company, Division of PES and Panasonic Ecology Systems Co., Ltd. certify that the Industrial Ventilation Fan – High Pressure Series shown herein are licensed to bear the AMCA Seal. The ratings shown are based on tests and procedures performed in accordance with AMCA Publication 211 and AMCA Publication 311 and comply with the requirements of the AMCA Certified Ratings Program.



### Specification

Model	Voltage [V]	Frequency [Hz]	CFM / SONE AT STATIC Pressure (ps-inches of H <sub>2</sub> O)				RPM	Watts* FOR AMCA	Watts** FOR IEC	
			Inches of H <sub>2</sub> O	0	0.2	0.3				0.4
45GSC	220	60	CFM	3,278	3,131	3,001	2,795	1,563	346	325
			Sones	10	10.4	10.6	10.8			
50GSC	240	50	CFM	2,854	2,648	2,454	2,030	1,430	277	241
			Sones	7.8	7.7	7.8	9.4			
60GSC	220	60	CFM	3,884	3,443	3,090	2,501	1,080	347	326
			Sones	10.9	11.3	11.5	11.8			
50GSC	240	50	CFM	3,354	2,854	2,266	912	968	293	271
			Sones	11.7	13.8	14.5	15.4			
60GSC	220	60	CFM	5,038	4,349	3,943	3,560	1,088	384	361
			Sones	10.1	9.8	9.5	10.1			
60GSC	240	50	CFM	4,402	3,855	3,366	2,972	980	289	263
			Sones	10.3	8.6	8.5a	11.5			

Performance certified is for installation type A: Free inlet, Free outlet with partition. Performance ratings do not include the effects of appurtenances (accessories). The Speed (RPM) and Watts rating shown are at the static pressure of 0 inch of H<sub>2</sub>O. The sound ratings shown are loudness values in fan sones at 5 ft. (1.5m) in a hemispherical free field calculated per AMCA International Standard 301. Values shown are for installation type A: Free inlet hemispherical sone levels.

\*the Watts rating is only for AMCA test method and it is at the statistic pressure of 0 inch of H<sub>2</sub>O.

\*\*the Watts rating is only for IEC test method.

### Wiring Diagram

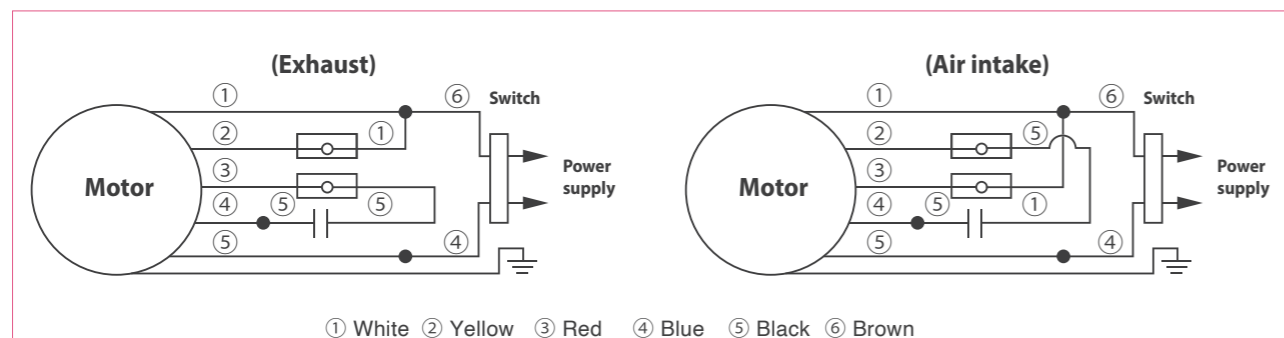

# High Pressure Series

Usage: Factory Warehouse Retail Store Commercial Kitchen

## 45GTC / 50GTC / 60GTC

Three Phase

Reversible

Optional Shutter

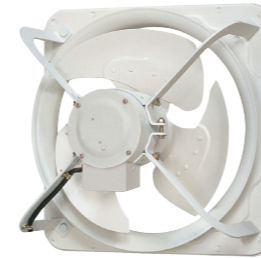

Model	A	B	C	D	E	F	G	H
40GSE	518	485	280	460	274	12	12	400

Dimension  
Unit : mm

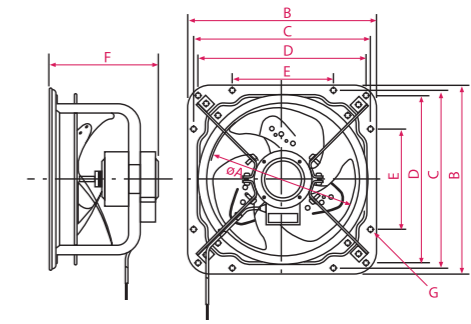

- Bell mouth construction with distinctive wave-shaped blade
- Durable powder coating
- Operable at an ambient temperature range from -10°C to +50°C
- Possible to install horizontally or vertically
- Motor insulation Class E

### Specification

Model	Voltage		Air Volume		Consumption [W]	RPM	Noise [dB(A)]	Weight [kg]
	[V]	[Hz]	[CMH]	[CFM]				
45GTC	380	50	5,520	3,249	220	1,450	52	18.5
		60	6,420	3,779	330	1,690	56	
50GTC	380	50	6,960	4,097	320	1,400	54	28.5
		60	8,010	4,715	475	1,590	58	
60GTC	380	50	9,420	5,544	310	940	49	34
		60	10,920	6,427	450	1,070	53	

Performance certified is for installation type A: Free inlet, Free outlet with partition. Performance ratings include the effects of an inlet grill and backdraft damper. The speed (RPM) and Watts rating shown are at the static pressure of 0 inch of H<sub>2</sub>O. The sound ratings shown are loudness values in fan sones at 5 ft. (1.5m) in a hemispherical free field calculated per AMCA International Standard 301. Values shown are for installation type A: Free inlet hemispherical sone levels.

\*the Watts rating is only for AMCA test method and it is at the static pressure of 0 inch of H<sub>2</sub>O.

\*\*the Watts rating is only for IEC test method and the AMCA Certified Ratings Seal does not apply to IEC test method watts.

### Performance Data

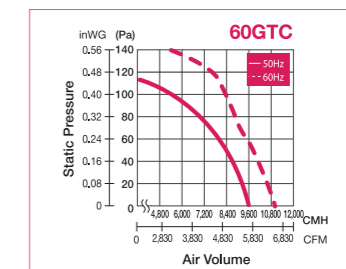
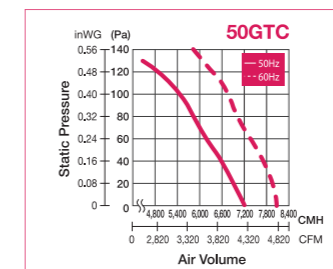
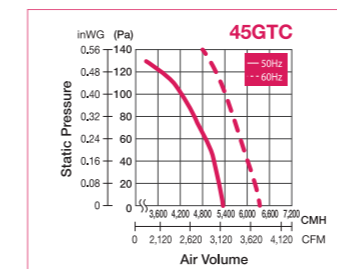

### Wiring Diagram

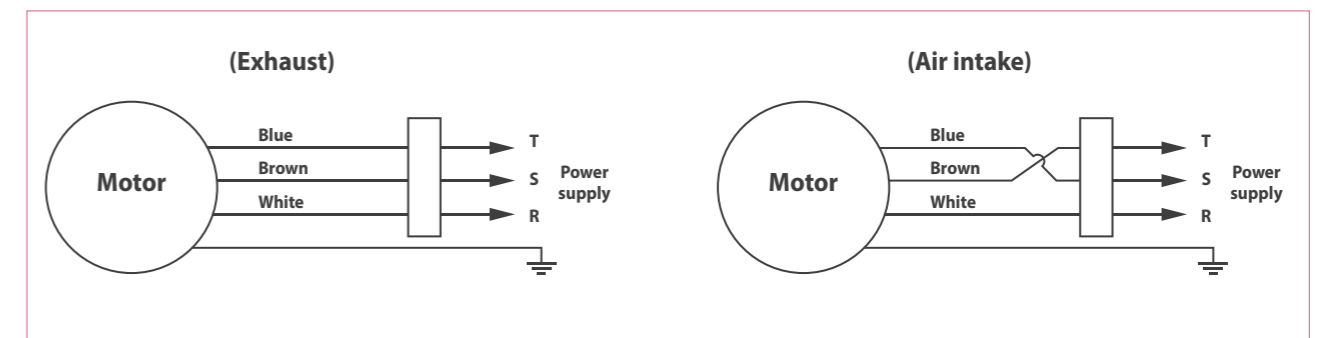

# Optional Accessories

25GASC / 30GASC / 35GASC  
40GASC / 45GASC / 50GASC / 55GASC

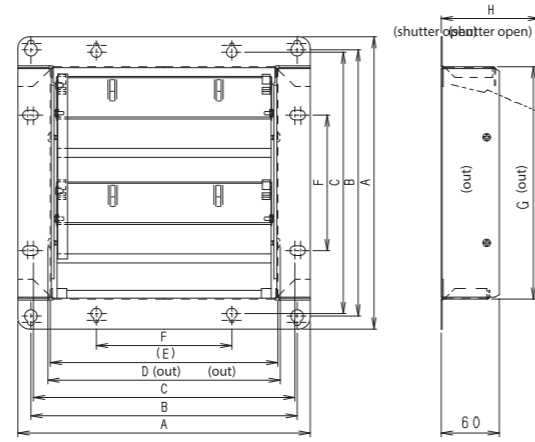

- Auto shutter for High Pressure Series
- Steel material
- Durable powder coating
- Available for wall mounting

**Dimension** Unit : mm

Model	Size	A	B	C	D	E	F	G	H	No. of Shutter	Applicable for
25GASC	25cm/10"	330	303	298	268	263	165	268	137	2	25GSE
30GASC	30cm/12"	381	354	349	319	314	210	319	122	3	30GSE
35GASC	35cm/14"	468	433	434	389	384	250	389	137	3	35GSE
40GASC	40cm/16"	519	484	485	440	435	280	440	122	4	40GSE
45GASC	45cm/18"	574	539	540	492	487	320	492	137	5	45GSC,45GTC
50GASC	50cm/20"	660	625	620	545	540	355	545	122	5	50GSC,50GTC
55GASC	60cm/24"	760	725	720	662	657	440	662	122	6	60GSC,60GTC

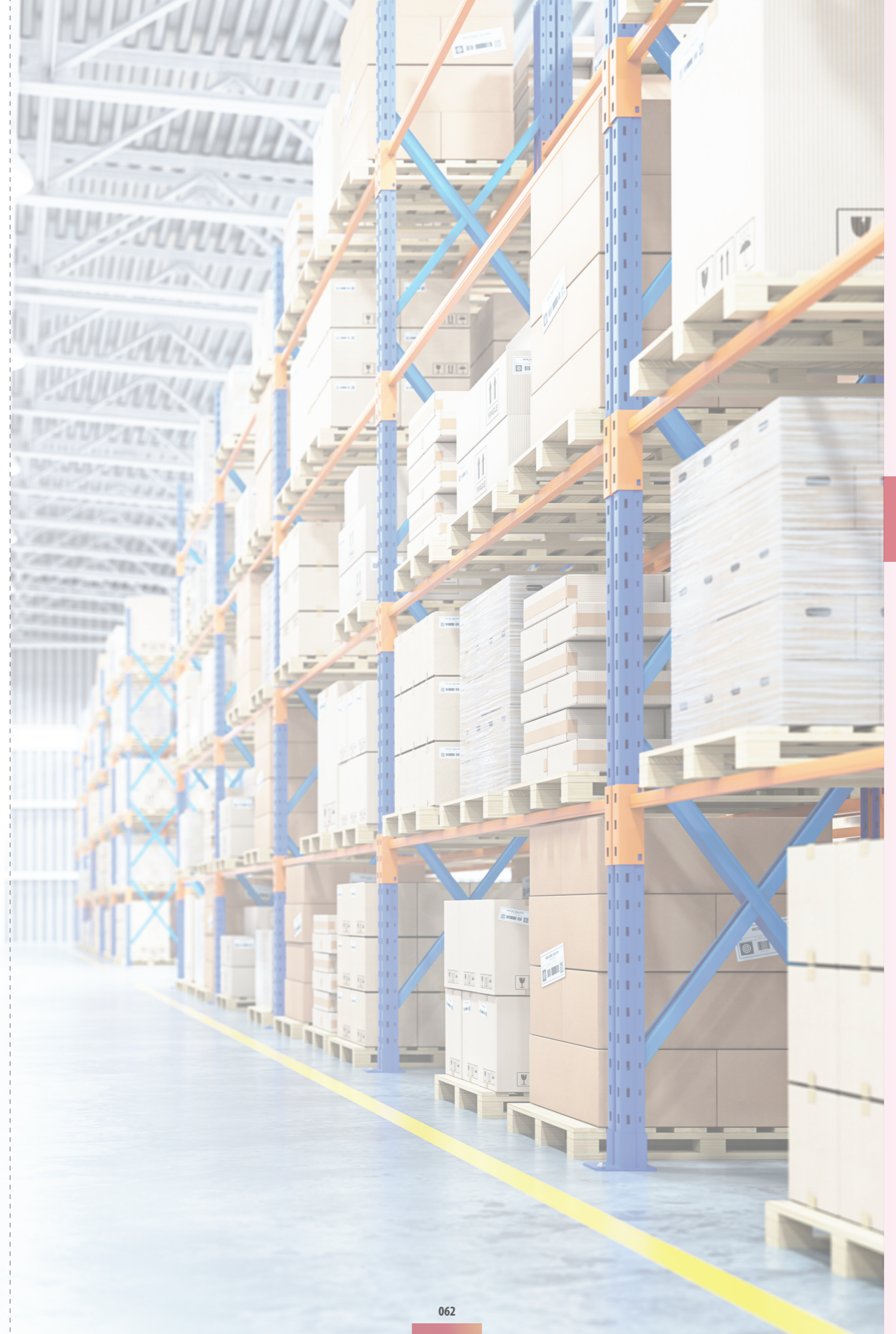

# Cabinet Fan (In-line Fan)

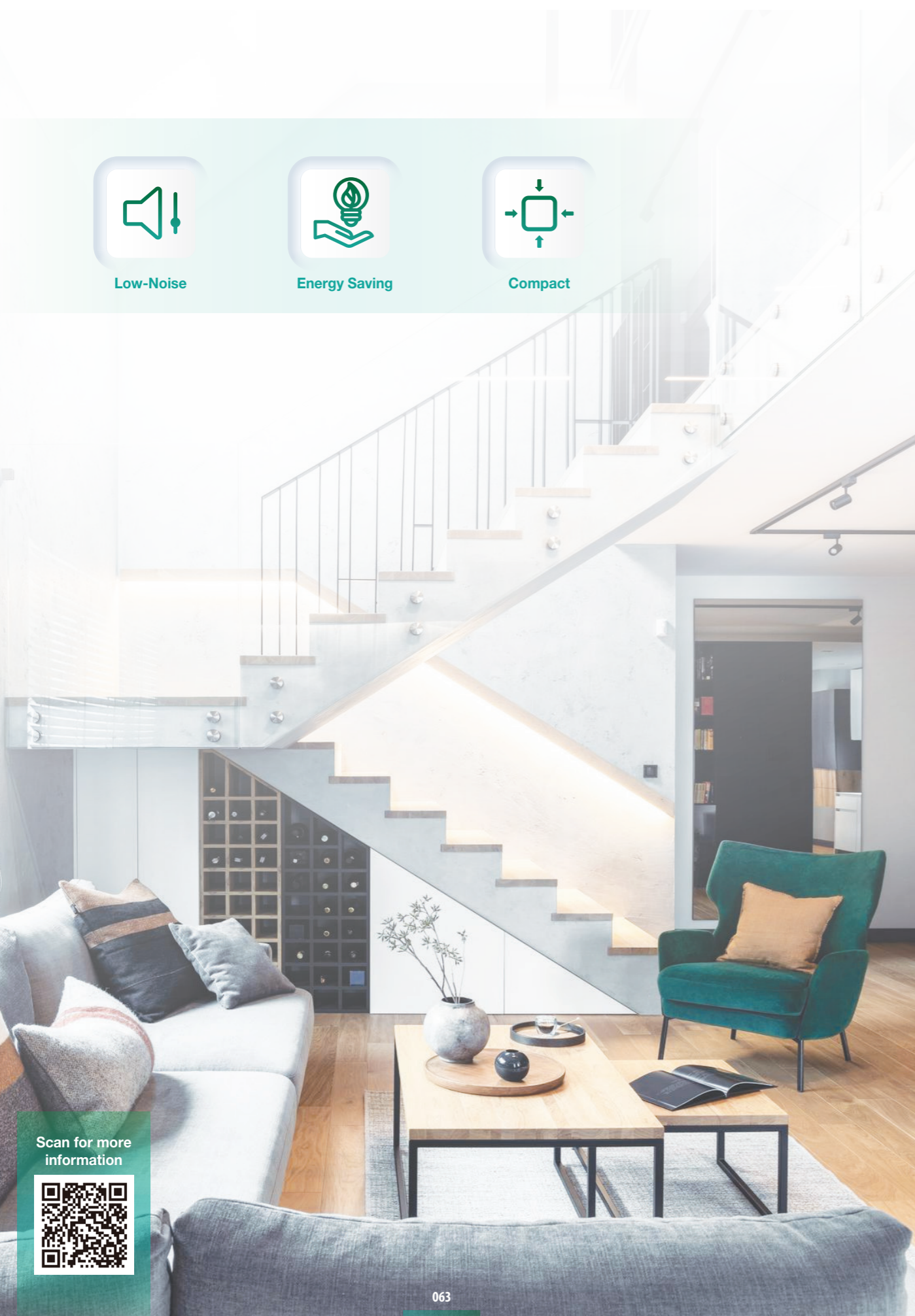

Low-Noise



Energy Saving



Compact

Scan for more information



## Low-noise Design

The newly developed twin flow fan achieves a better airflow inside the fan casing. It is divided into two portions which can generate large air volume and high static pressure respectively.

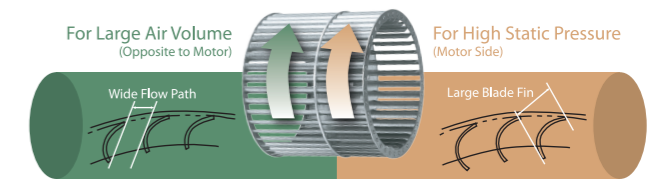

## Tapered Scroll

Wind velocity varies according to the shape of the casing. The tapered scroll at the casing minimizes turbulence induced by uneven wind velocity inside the casing.

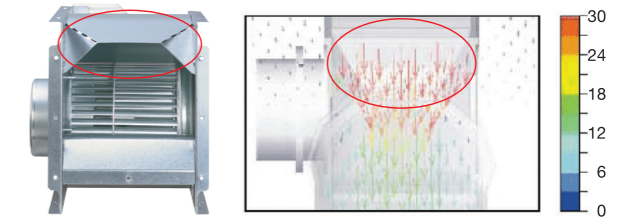

Internal Wind Velocity Distribution - Airflow Analysis

## Embedded Terminal Box

Terminal box is embedded into the product frame. The wiring to power supply is covered with metal enclosure that enhances the durability and safety level.

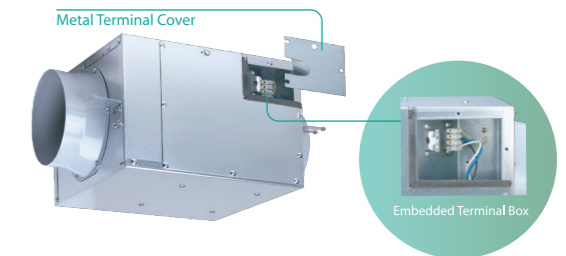

## High Static Pressure

The distinctive design of twin flow fan and fan casing enable operation with high static pressure, which is approximate 10% average increased when compared with previous models. This increases the flexibility in your planning of ventilating system.

## Energy Saving

The new structure design improves fan performance by increasing energy efficiency by 3%. In addition, energy saving is assured by reducing motor power consumption significantly.

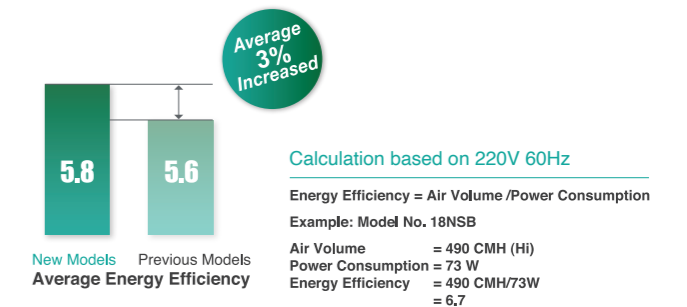

## Noise Reduction

With the twin flow fan and fan casing structure, the new models minimize the transmission of noise and reduce it by 6% while maintaining air volume. This technology creates a more tranquil and pleasant environment.

## Easy Installation

A slim, compact and light body allows easy installation in narrow ceiling space, when compared with previous models.

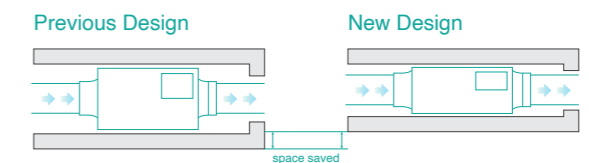

## Compact Size

With the newly designed structure, the product size is reduced by 9%, which increases the flexibility in installation.

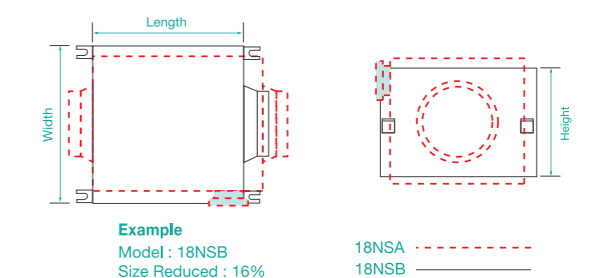

Example Model: 18NSB Size Reduced: 16%

18NSA 18NSB

# Standard Series

Usage: Living Room Shopping Mall Restaurant

## 12NSB / 15NSB

- Sirocco Fan
- Low Noise Design
- Compact Size

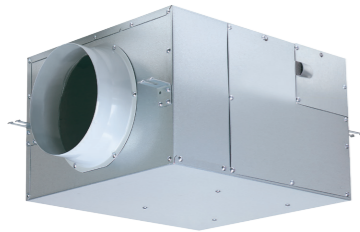

### Dimension Unit : mm

Model	A	B	C	D	E	F	G	H	I
12NSB	290	250	291	335	184	92	97	112	51
15NSB	290	250	302	346	206	103	145	163	60

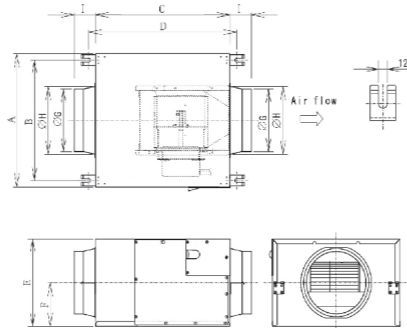

- Long life condenser motor with thermal cut-off
- Twin flow fan (sirocco fan)
- Fan casing with tapered scroll
- Embedded terminal box
- Noise absorption material adopted
- Motor insulation Class E
- IP protection: IPX2

KDK Company, Division of PES and Panasonic Ecology Systems Guangdong Co., Ltd. certify that the Cabinet Fan – Standard Series shown herein are licensed to bear the AMCA Seal. The ratings shown are based on tests and procedures performed in accordance with AMCA Publication 211 and AMCA Publication 311 and comply with the requirements of the AMCA Certified Ratings Program.

### Specification

Model	Voltage [V]	Frequency [Hz]	CFM/SONE AT STATIC Pressure (ps-inches of H <sub>2</sub> O)											RPM	Watts* FOR AMCA	Watts** FOR IEC
			inches of H <sub>2</sub> O	0	0.1	0.125	0.25	0.375	0.5	0.75	1	1.25	1.5			
12NSB	220	60	CFM	114	105	102	87	65	-	-	-	-	-	1,460	26	23
			Sones	1.5	1.4	1.4	1.3	1.4	-	-	-	-	-			
15NSB	240	50	CFM	102	90	86	67	39	-	-	-	-	-	1,342	27	22
			Sones	2.0	1.7	1.6	1.4	1.5	-	-	-	-	-			
12NSB	220	60	CFM	200	183	177	149	118	83	-	-	-	-	1,520	45	42
			Sones	2.7	2.5	2.4	2.3	2.2	2.0	-	-	-	-			
15NSB	240	50	CFM	193	177	172	139	94	20	-	-	-	-	1,373	47	37
			Sones	3.7	3.4	3.2	2.6	2.5	2.8	-	-	-	-			

Performance certified is for installation type D: Ducted inlet, Ducted outlet.  
 Performance ratings do not include the effects of appurtenances (accessories). Speed (RPM) shown is nominal.  
 Performance is based on actual speed of test. The sound ratings shown are loudness values in fan sones at 5 ft (1.5m) in a hemispherical free field calculated per AMCA International Standard 301.  
 Values shown are for installation Type D: ducted inlet hemispherical sone levels. Ratings do not include the effect of duct end correction.  
 \* the Watts rating is only for AMCA test method and it is at the static pressure of 0 inch of H<sub>2</sub>O.  
 \*\* the Watts rating is only for IEC test method and the AMCA Certified Ratings Seal does not apply to IEC test method watts.

### Wiring Diagram

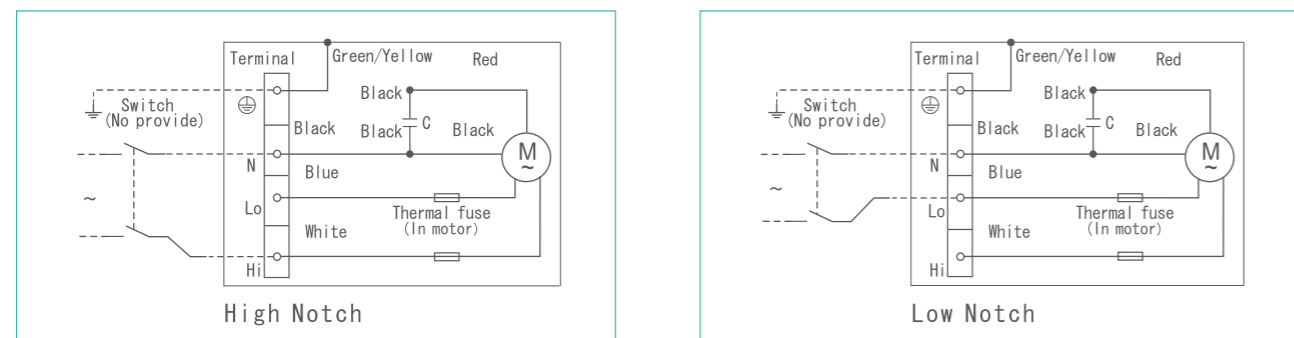

# Standard Series

Usage: Living Room Shopping Mall Restaurant

## 18NSB / 18NFB

- Sirocco Fan
- Low Noise Design
- Compact Size

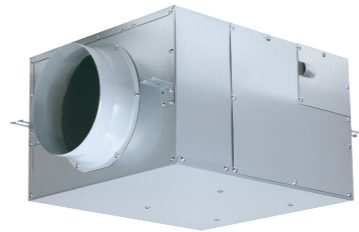

### Dimension Unit : mm

Model	A	B	C	D	E	F	G	H	I
18NSB	316	276	338	382	232	116	145	163	60
18NFB	376	336	397	441	254	127	195	211	70

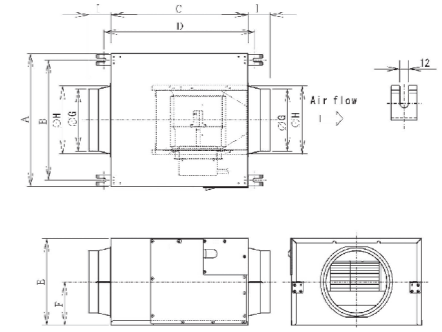

- Long life condenser motor with thermal cut-off
- Twin flow fan (sirocco fan)
- Fan casing with tapered scroll
- Embedded terminal box
- Noise absorption material adopted
- Motor insulation Class E
- IP protection: IPX2

KDK Company, Division of PES and Panasonic Ecology Systems Guangdong Co., Ltd. certify that the Cabinet Fan – Standard Series shown herein are licensed to bear the AMCA Seal. The ratings shown are based on tests and procedures performed in accordance with AMCA Publication 211 and AMCA Publication 311 and comply with the requirements of the AMCA Certified Ratings Program.

### Specification

Model	Voltage [V]	Frequency [Hz]	CFM/SONE AT STATIC Pressure (ps-inches of H <sub>2</sub> O)											RPM	Watts* FOR AMCA	Watts** FOR IEC
			inches of H <sub>2</sub> O	0	0.1	0.125	0.25	0.375	0.5	0.75	1	1.25	1.5			
18NSB	220	60	CFM	274	261	258	241	222	196	137	-	-	-	1,470	80	73
			Sones	3.3	3.1	3.0	2.9	2.7	2.6	2.7	-	-	-			
18NSB	240	50	CFM	281	263	259	232	200	163	34	-	-	-	1,342	84	68
			Sones	4.8	4.4	4.4	3.8	3.4	3.0	2.9	-	-	-			
18NFB	220	60	CFM	417	399	395	373	347	318	237	-	-	-	1,420	128	119
			Sones	4.0	3.9	3.9	3.6	3.5	3.4	-	-	-				
18NFB	240	50	CFM	429	406	400	381	344	290	78	-	-	-	1,327	135	104
			Sones	5.6	5.4	5.4	5.1	4.6	4.3	4.2	-	-	-			

Performance certified is for installation type D: Ducted inlet, Ducted outlet.  
 Performance ratings do not include the effects of appurtenances (accessories). Speed (RPM) shown is nominal.  
 Performance is based on actual speed of test. The sound ratings shown are loudness values in fan sones at 5 ft (1.5m) in a hemispherical free field calculated per AMCA International Standard 301.  
 Values shown are for installation Type D: ducted inlet hemispherical sone levels. Ratings do not include the effect of duct end correction.  
 \* the Watts rating is only for AMCA test method and it is at the static pressure of 0 inch of H<sub>2</sub>O.  
 \*\* the Watts rating is only for IEC test method and the AMCA Certified Ratings Seal does not apply to IEC test method watts.

### Wiring Diagram

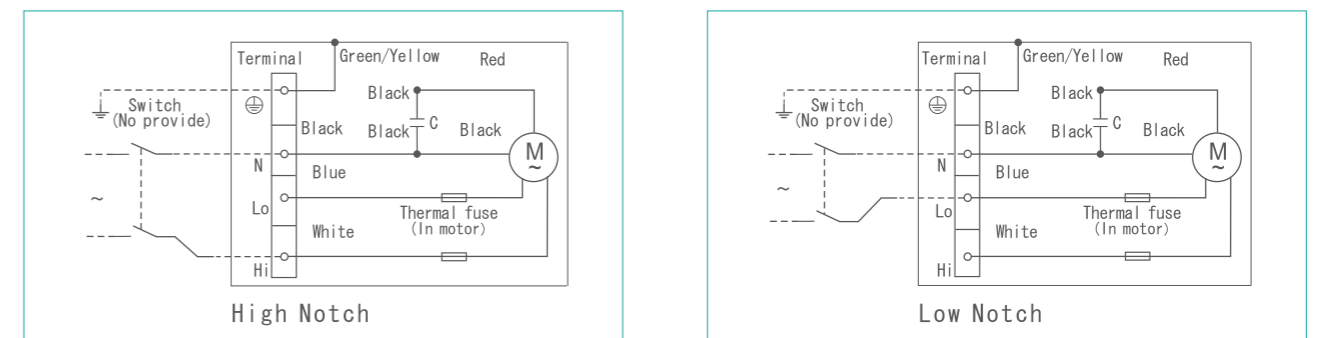

# Standard Series

Usage: Living Room Shopping Mall Restaurant

## 20NSB / 23NLB

- Sirocco Fan
- Low Noise Design
- Compact Size

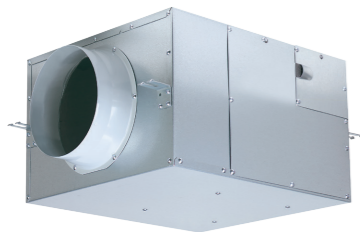

- Long life condenser motor with thermal cut-off
- Twin flow fan (sirocco fan)
- Fan casing with tapered scroll
- Embedded terminal box
- Noise absorption material adopted
- Motor insulation Class E
- IP protection: IPX2

### Dimension

Unit : mm

Model	A	B	C	D	E	F	G	H	I
20NSB	416	376	441	485	272	136	195	211	70
23NLB	468	424	469	513	298	149	195	211	70

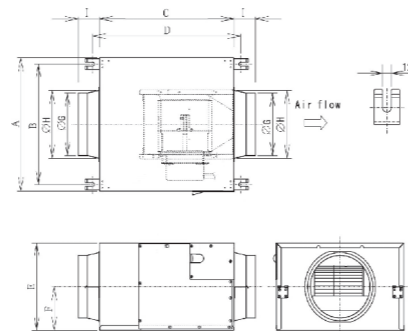

KDK Company, Division of PES and Panasonic Ecology Systems Guangdong Co., Ltd. certify that the Cabinet Fan – Standard Series shown herein are licensed to bear the AMCA Seal. The ratings shown are based on tests and procedures performed in accordance with AMCA Publication 211 and AMCA Publication 311 and comply with the requirements of the AMCA Certified Ratings Program.

### Specification

Model	Voltage [V]	Frequency [Hz]	CFM/SONE AT STATIC Pressure (ps-inches of H <sub>2</sub> O)											RPM	Watts* FOR AMCA	Watts** FOR IEC
			inches of H <sub>2</sub> O	0	0.1	0.125	0.25	0.375	0.5	0.75	1	1.25	1.5			
20NSB	220	60	CFM	469	459	456	444	433	413	354	275	-	-	1,380	170	159
			Sones	4.0	4.0	3.9	3.8	3.9	4.0	4.1	4.2	-	-			
20NSB	240	50	CFM	517	500	495	464	424	382	265	110	-	-	1,328	175	135
			Sones	6.0	5.8	5.8	5.4	5.1	4.8	4.5	4.5	-	-			
23NLB	220	60	CFM	655	642	640	625	611	597	555	505	440	-	1,400	350	310
			Sones	6.0	6.0	5.9	5.9	5.7	5.7	5.8	5.8	5.8	-			
23NLB	240	50	CFM	688	670	664	642	614	579	493	388	199	-	1,342	347	260
			Sones	8.8	8.6	8.4	8.1	8.0	7.6	7.2	6.7	6.6	-			

Performance certified is for installation type D: Ducted inlet, Ducted outlet.  
 Performance ratings do not include the effects of appurtenances (accessories). Speed (RPM) shown is nominal.  
 Performance is based on actual speed of test. The sound ratings shown are loudness values in fan sones at 5 ft (1.5m) in a hemispherical free field calculated per AMCA International Standard 301.  
 Values shown are for installation Type D: ducted inlet hemispherical sone levels. Ratings do not include the effect of duct end correction.  
 \* the Watts rating is only for AMCA test method and it is at the static pressure of 0 inch of H<sub>2</sub>O.  
 \*\* the Watts rating is only for IEC test method and the AMCA Certified Ratings Seal does not apply to IEC test method watts.

### Wiring Diagram

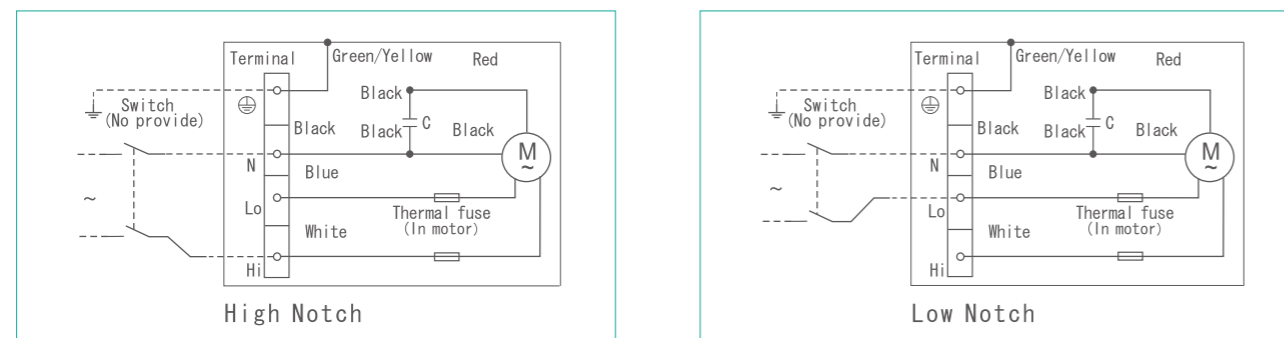

# Standard Series

Usage: Living Room Shopping Mall Restaurant

## 25NSB / 25NFB

- Sirocco Fan
- Low Noise Design
- Compact Size

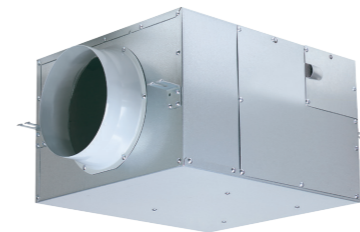

- Long life condenser motor with thermal cut-off
- Twin flow fan (sirocco fan)
- Fan casing with tapered scroll
- Embedded terminal box
- Noise absorption material adopted
- Motor insulation Class E
- IP protection: IPX2

### Dimension

Unit : mm

Model	A	B	C	D	E	F	G	H	I
25NSB	494	450	505	549	334	167	240	255	85
25NFB	494	450	505	549	334	167	240	255	85

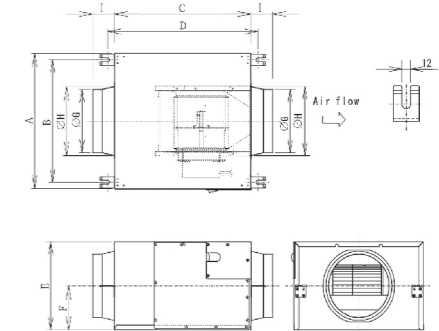

KDK Company, Division of PES and Panasonic Ecology Systems Guangdong Co., Ltd. certify that the Cabinet Fan – Standard Series shown herein are licensed to bear the AMCA Seal. The ratings shown are based on tests and procedures performed in accordance with AMCA Publication 211 and AMCA Publication 311 and comply with the requirements of the AMCA Certified Ratings Program.

### Specification

Model	Voltage [V]	Frequency [Hz]	CFM/SONE AT STATIC Pressure (ps-inches of H <sub>2</sub> O)											RPM	Watts* FOR AMCA	Watts** FOR IEC
			inches of H <sub>2</sub> O	0	0.1	0.125	0.25	0.375	0.5	0.75	1	1.25	1.5			
25NSB	220	60	CFM	940	924	919	899	877	857	790	710	610	502	1,380	460	425
			Sones	7.1	7.1	7.1	7.0	6.8	6.8	6.7	6.7	6.7	6.9			
25NSB	240	50	CFM	963	938	935	906	868	822	719	567	395	-	1,305	481	370
			Sones	10.1	9.8	9.7	9.3	9.2	8.8	8.0	7.5	8.2	-			
25NFB	220	60	CFM	1,016	1,000	995	975	954	933	875	803	710	590	1,420	680	520
			Sones	8.2	8.2	8.2	8.2	7.9	7.9	7.8	7.6	7.5	7.5			
25NFB	240	50	CFM	1,057	1,048	1,040	1,010	972	922	811	660	473	-	1,330	537	430
			Sones	12.1	11.9	11.5	11.1	10.6	9.8	8.7	8.7	10.3	-			

Performance certified is for installation type D: Ducted inlet, Ducted outlet.  
 Performance ratings do not include the effects of appurtenances (accessories). Speed (RPM) shown is nominal.  
 Performance is based on actual speed of test. The sound ratings shown are loudness values in fan sones at 5 ft (1.5m) in a hemispherical free field calculated per AMCA International Standard 301.  
 Values shown are for installation Type D: ducted inlet hemispherical sone levels. Ratings do not include the effect of duct end correction.  
 \* the Watts rating is only for AMCA test method and it is at the static pressure of 0 inch of H<sub>2</sub>O.  
 \*\* the Watts rating is only for IEC test method and the AMCA Certified Ratings Seal does not apply to IEC test method watts.

### Wiring Diagram

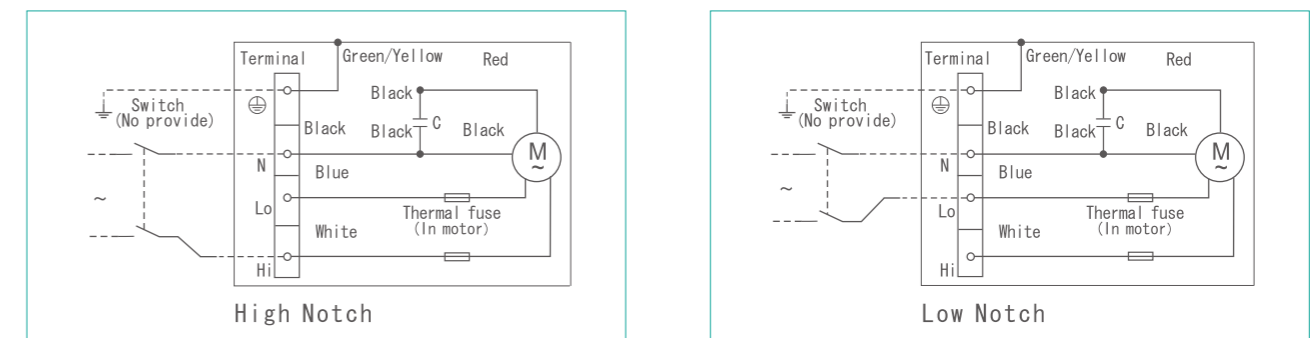

# Standard Series

Usage: Living Room Shopping Mall Restaurant

## 25SWC / 25SMC

- Sirocco Fan
- Low Noise Design
- Compact Size



- Long life condenser motor with thermal cut-off
- Twin flow fan (sirocco fan)
- Fan casing with tapered scroll
- Embedded terminal box
- Noise absorption material adopted
- Motor insulation Class F
- IP protection: IPX2

### Dimension

Unit : mm

Model	A	B	C	D	E	F	G	H	I
25SWC	809	496	1,010	1,052	942	246	185	370	766
25SMC	809	696	1,010	1,052	942	246	185	370	766

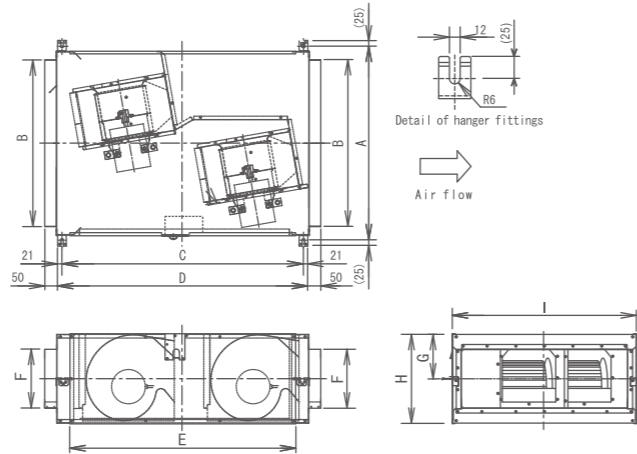

# Standard Series

Usage: Living Room Shopping Mall Restaurant

## 28NXC

- Sirocco Fan
- Low Noise Design
- Compact Size

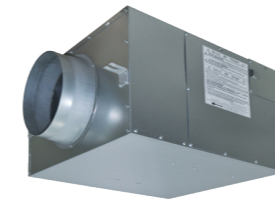

- Long life condenser motor with thermal cut-off
- Twin flow fan (sirocco fan)
- Fan casing with tapered scroll
- Embedded terminal box
- Noise absorption material adopted
- Motor insulation Class F
- IP protection: IPX2

### Dimension

Unit : mm

Model	A	B	C	D	E	F	G	H	I
28NXC	554	510	557	601	342	171	240	255	85

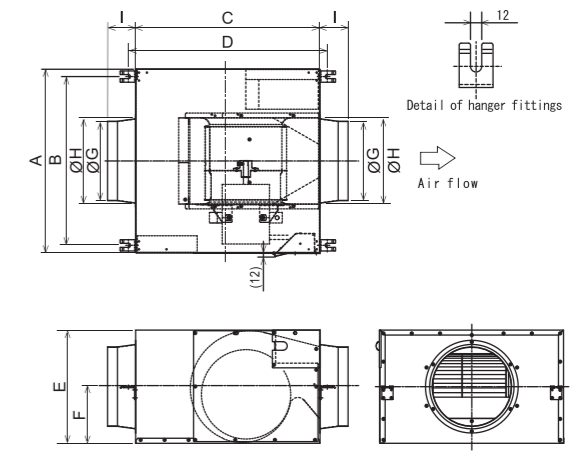

### Specification

Model	Phase	Voltage [V]	Frequency [Hz]	Consumption [W]	RPM	Air Volume		Noise [dB(A)]	Weight [kg]	Duct Size [mm]	Impeller Diameter [mm]
						[CMH]	[CFM]				
25SWC	3	380	50	940	1,375	4,000	2,354	43	60	250 x 250	250
			60	1,450	1,530	4,500	2,648	45			
25SMC	3	380	50	1,180	1,345	5,200	3,060	45	60	250 x 700	250
			60	1,750	1,470	5,500	3,237	46			

Note:  
The value in specification tables are representative characteristic value at 380V 50/60Hz.  
RPM data is for reference only. Values may vary subject to different conditions.

### Specification

Model	Phase	Voltage [V]	Frequency [Hz]	Consumption [W]	RPM	Air Volume		Noise [dB(A)]	Weight [kg]	Duct Size [mm]	Impeller Diameter [mm]
						[CMH]	[CFM]				
28NXC	3	380	50	600	1,295	2,600	1,530	44	28	Ø250	280
			60	840	1,380	2,650	1,560	45			

Note:  
The value in specification tables are representative characteristic value at 380V 50/60Hz.  
RPM data is for reference only. Values may vary subject to different conditions.

### Performance Data (380V 50/60Hz)

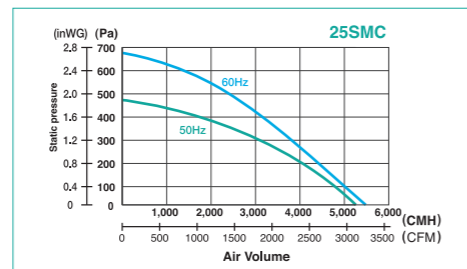
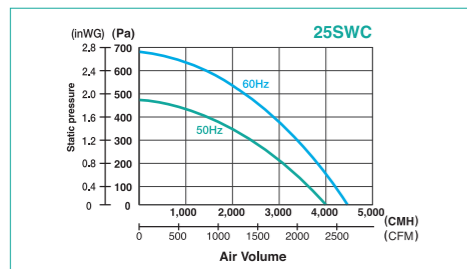

### Performance Data (380V 50/60Hz)

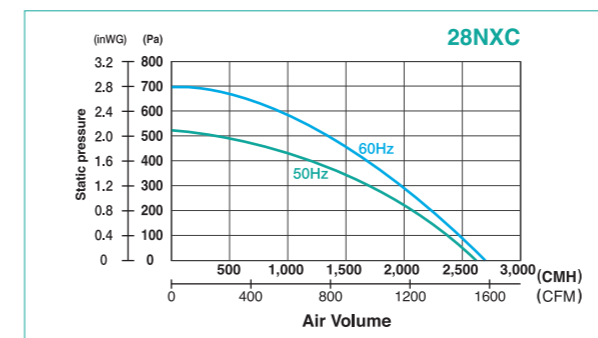

### Wiring Diagram

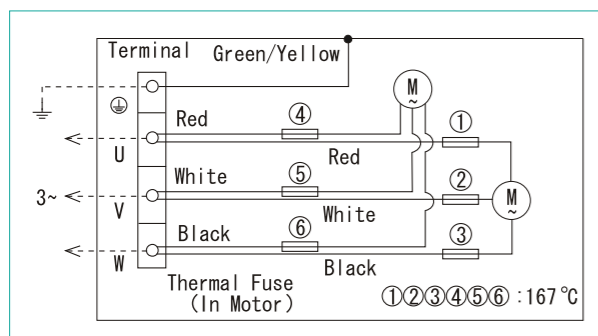

### Wiring Diagram

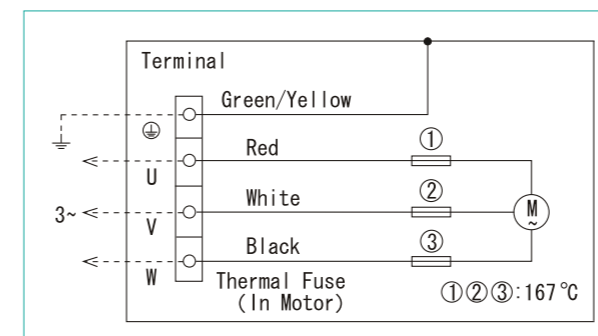

# Mini Sirocco Fan



High Performance



Durable



Easy Installation



Scan for more information



# Mini Sirocco Fan

## More Compact

With the optimal air passage design, the body size is compact. It enables easy installation in narrow and limited space environment.

## Higher Duct Connectivity

After the improvement on the adapter design, the duct connectivity is enhanced with the extended adapter.

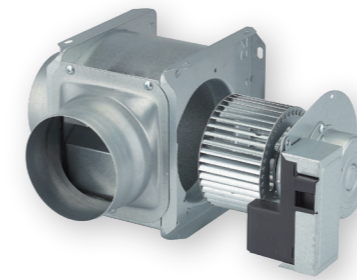
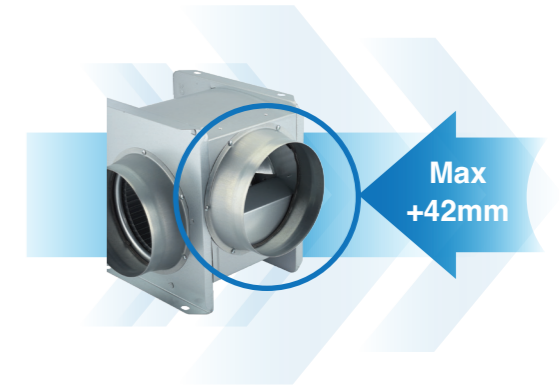

## Simplified Maintenance

By unitizing the fan and motor as one single unit, the impeller can be replaced and cleaned without removing the duct. It facilitates more user-friendly maintenance.

## Easy Installation

The inlet and outlet of the sirocco fan are of the same size for easy connection to a ducted system. The fan can be mounted on the ceiling.

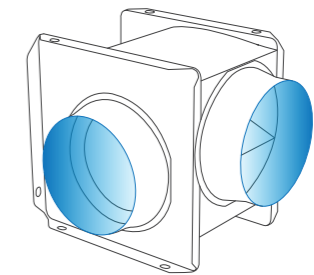

## Adjustable Outlet Direction

With the mounting feet on the fan body, installation has become easier. Outlet direction is adjustable to fit vertical or horizontal position.

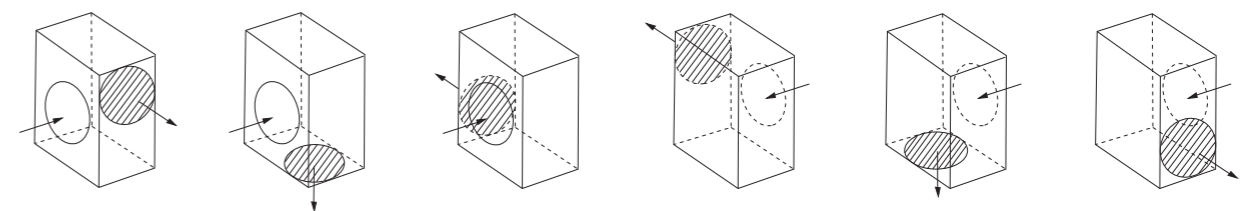

Various installing patterns satisfy different installation space

# Mini Sirocco Fan

Usage: Locations where high air volume is needed

10CGB / 12CGB / 14CGB  
16CGB / 17CGB / 19CGB / 21CGB

- Optimal Air Passage
- High Duct Connectivity
- Easy Installation

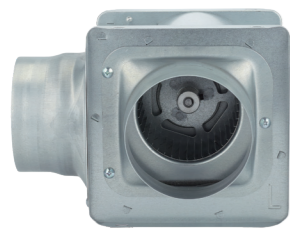

- Forward curve fan
- Galvanized steel
- Compact size for narrow space installation
- Extended adapter for higher connectivity
- Long life induction motor with thermal cut-off
- Well-lubricated ball bearing for long life operation
- Highly efficient sirocco fan designed for powerful airflow
- Outlet direction adjustable to vertical or horizontal position
- Motor IP rating:  
Class E for 10CGB, 12CGB, 14CGB, 16CGB, 17CGB & 19CGB  
Class F for 21CGB
- Insulation class: IPX2

## Wiring Diagram

- Wiring connection when not use speed switch.

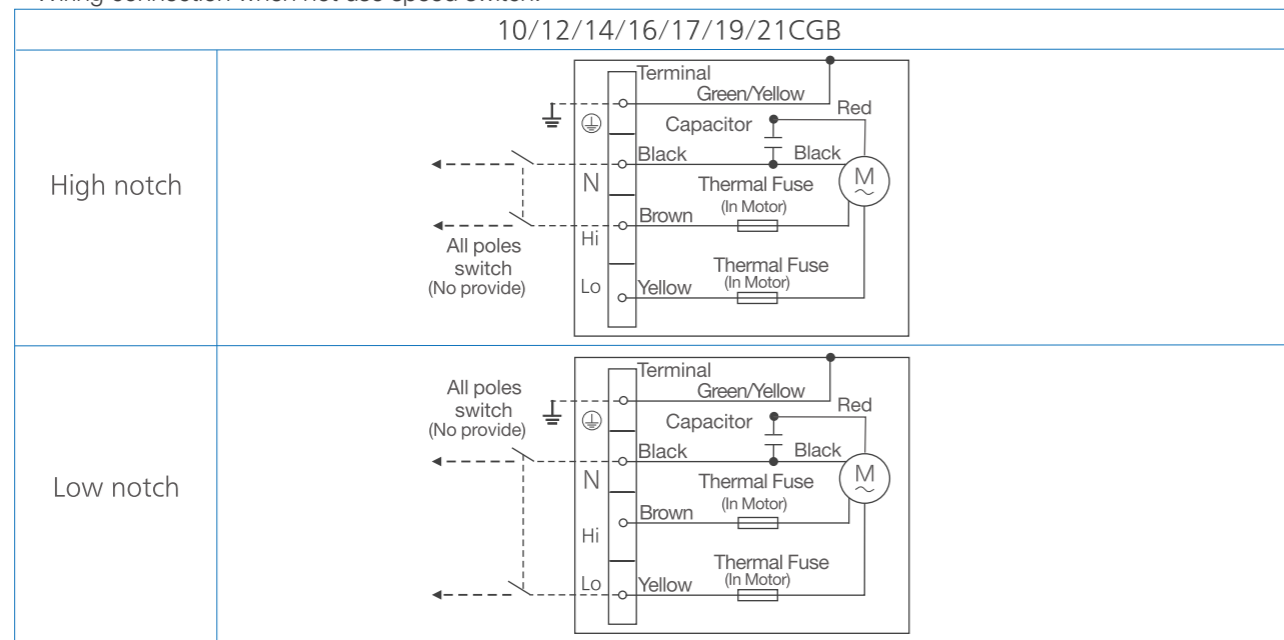

- Wiring connection when use speed switch.

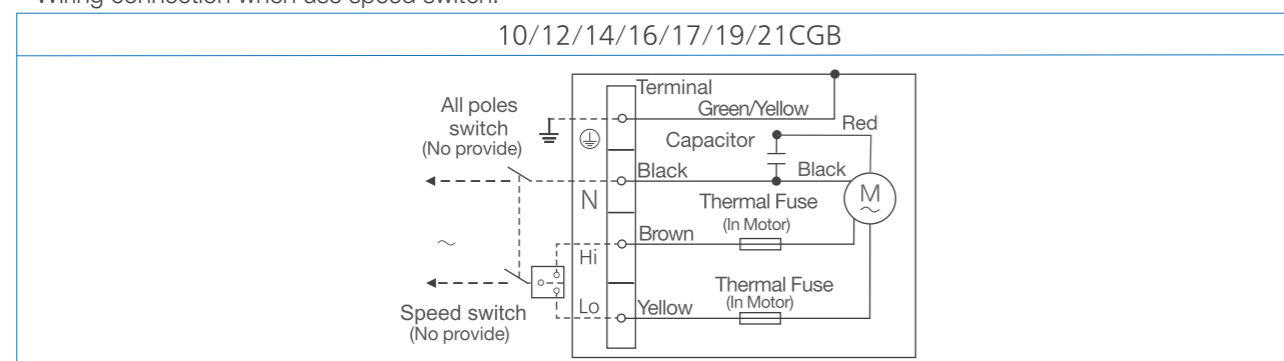

## Dimensions Unit: mm

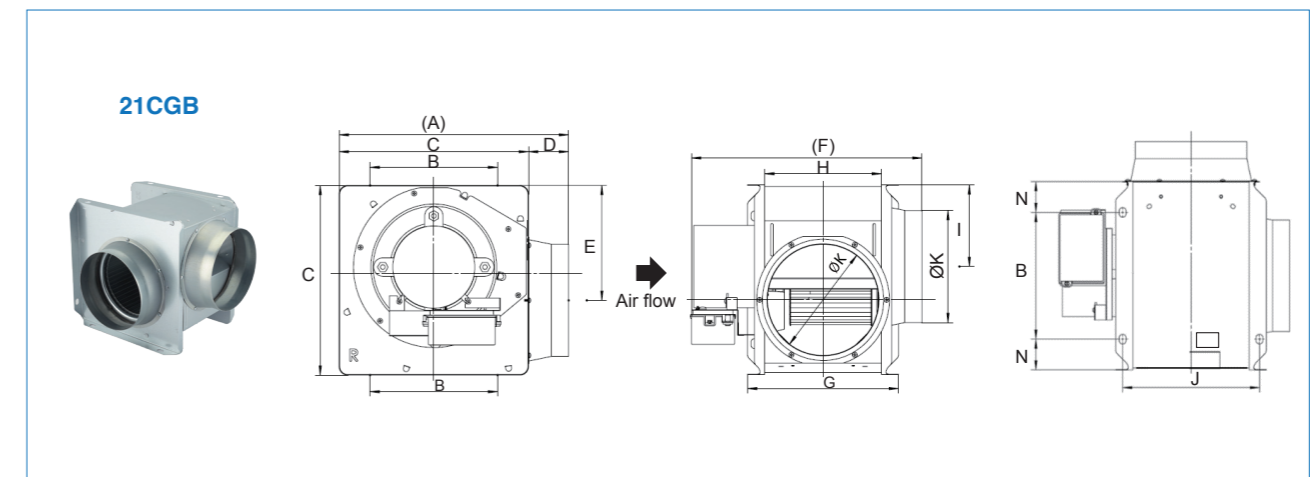
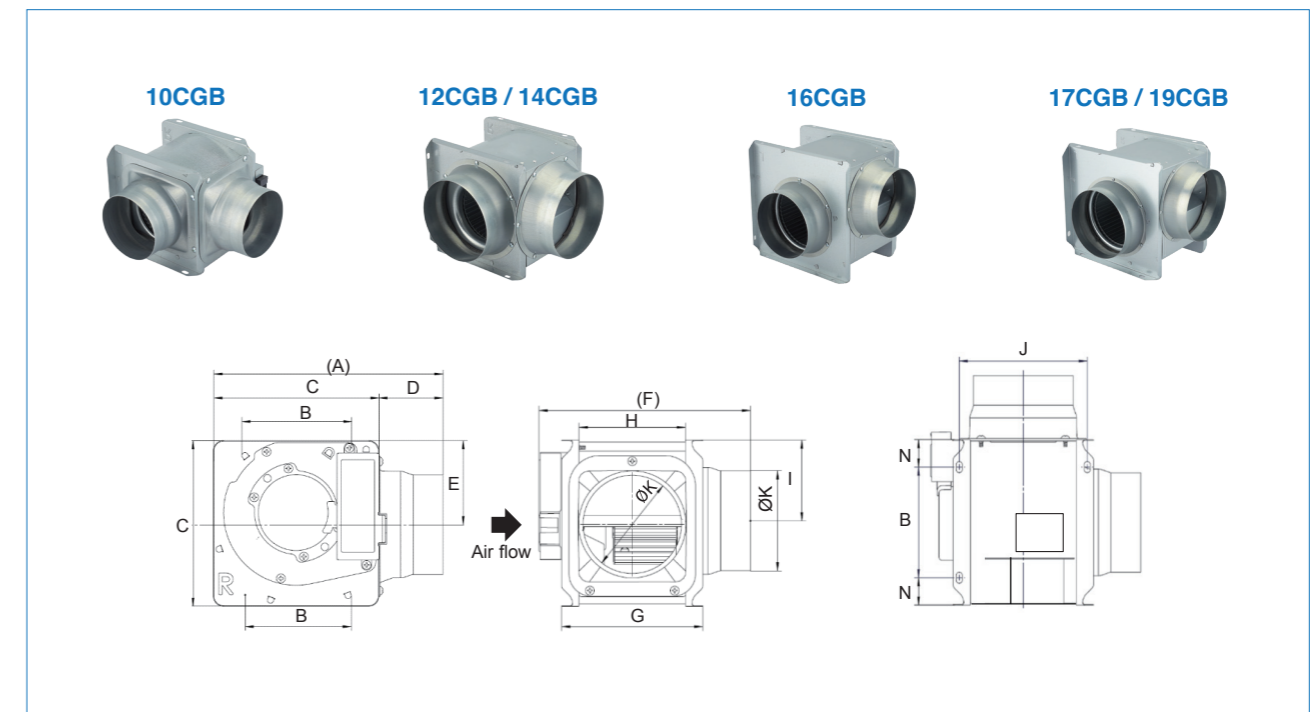

Model	A	B	C	D	E	F	G	H	I	J	K	N	Connector Duct Dimension (mm)
10CGB	226	109	163	63	83	207	138	104	79	126	98	27	Ø100
12CGB	269	145	209	60	112	236	170	136	101	158	146	32	Ø150
14CGB													
16CGB	330	196	270	60	170	264	189	155	117	177	146	37	Ø150
17CGB	400	222	330	71	200	332	263	203	142	239	195	55	Ø200
19CGB													
21CGB	400	222	330	71	200	403	263	203	142	239	195	55	Ø200

# Specification

Model	Voltage [V]	Frequency [Hz]	Speed	Air Volume [CMH]	Consumption [W]	Noise Level [dB]		Net Weight [kg]
						Inlet	Side	
10CGB	220	50	Hi	154	15	41.0	28.0	1.9
			Lo	115	12	35.5	24.0	
		60	Hi	133	12	36.5	24.0	
			Lo	93	9	28.5	20.0	
	230	60	Hi	143	13	38.0	25.0	
			Lo	100	10	30.5	20.0	
	220-240	50	Hi	134-143	10-11	37.0-39.0	23.0-25.0	
			Lo	110-125	9-10	32.0-35.0	20.0-23.0	
12CGB	220	50	Hi	250	22	44.0	29.0	2.5
			Lo	175	16	32.0	19.0	
		60	Hi	225	25	42.5	29.0	
			Lo	145	18	32.0	21.0	
	230	60	Hi	242	27	44.0	30.0	
			Lo	153	19	34.0	21.5	
	220-240	50	Hi	233-262	23-28	44.5-46.5	29.0-32.0	
			Lo	156-175	19-23	33.0-36.0	18.0-20.0	
14CGB	220	50	Hi	332	35	50.0	34.0	2.8
			Lo	226	28	40.0	26.0	
		60	Hi	260	30	43.0	30.0	
			Lo	200	25	35.5	25.0	
	230	60	Hi	275	33	44.5	31.5	
			Lo	212	28	37.5	26.0	
	220-240	50	Hi	280-315	28-32	44.5-46.5	31.0-33.0	
			Lo	227-265	26-30	40.0-44.0	27.0-31.0	
16CGB	220	50	Hi	509	50	49.0	35.0	5.6
			Lo	405	43	43.5	30.0	
		60	Hi	483	57	48.0	32.0	
			Lo	372	44	41.0	27.0	
	230	60	Hi	503	61	49.0	34.5	
			Lo	393	48	42.5	29.0	
	220-240	50	Hi	509-542	50-56	49.0-51.5	35.0-38.0	
			Lo	405-450	43-48	43.5-46.0	30.0-32.0	

# Specification

Model	Voltage [V]	Frequency [Hz]	Speed	Air Volume [CMH]	Consumption [W]	Noise Level [dB]		Net Weight [kg]
						Inlet	Side	
17CGB	220	50	Hi	791	86	50.0	36.0	10.1
			Lo	640	70	44.0	31.0	
		60	Hi	752	95	49.0	34.0	
			Lo	612	73	43.5	29.0	
	230	60	Hi	789	104	50.0	35.0	
			Lo	641	80	44.0	31.0	
	220-240	50	Hi	791-875	86-101	50.0-52.5	36.0-39.0	
			Lo	640-705	70-83	44.0-47.0	31.0-32.0	
19CGB	220	50	Hi	947	121	55.0	41.0	10.2
			Lo	857	105	51.5	37.0	
		60	Hi	885	127	52.0	39.0	
			Lo	760	107	48.0	37.0	
	230	60	Hi	931	140	53.5	40.0	
			Lo	791	117	49.5	36.5	
	220-240	50	Hi	919-997	113-130	52.0-54.0	40.0-42.0	
			Lo	804-880	99-115	50.0-52.0	38.0-40.0	
21CGB	220	50	Hi	1420	238	67.0	54.0	14.6
			Lo	1143	182	60.0	47.0	
		60	Hi	1500	328	68.0	57.0	
			Lo	1042	215	58.0	47.0	
	230	60	Hi	1550	342	69.0	57.5	
			Lo	1100	230	59.5	48.0	
	220-240	50	Hi	1420-1435	238-247	66.0-67.0	54.0-55.0	
			Lo	1143-1220	182-197	60.0-62.5	47.0-51.0	

**Notes:**

- ① The values of rated input, air volume and noise are specified at the static pressure of 0 Pa.
- ② The values of noise level is A weighted average sound pressure level, the mean values are measured by our company, within +3 and -7 tolerance.
- ③ The values of noise level are measured at the 1.5m apart from the inspection panel of the fan body when ducts are connected on both inlet and outlet side. It is based on the assumption that the noise of fan body propagates to room inside.
- ④ The values of air volume are the mid-points of results measured by our company, with ±10% tolerance.

# Accessories - Pipe Hood

## MGX100K / MGX150K MCX100K / MCX150K

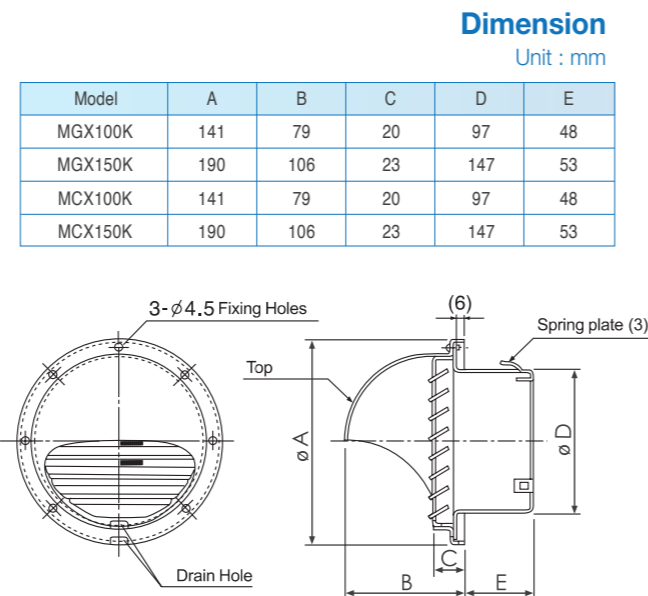

- High strength - adopt 0.5mm thickness SUS 304 Stainless steel
- Excellent anti-rust capability - hood part coated with metallic silver paint prevents oxidation of material
- Easy installation - 3pcs of spring clip facilitate duct/pipe connection
- 2.5x2.5mm net keep out ingress of small particles and insects from outside (MGX100K & MGX150K)
- It is recommended to use pipe hood with net at intake terminal while with-out net at exhaust

### Performance Data

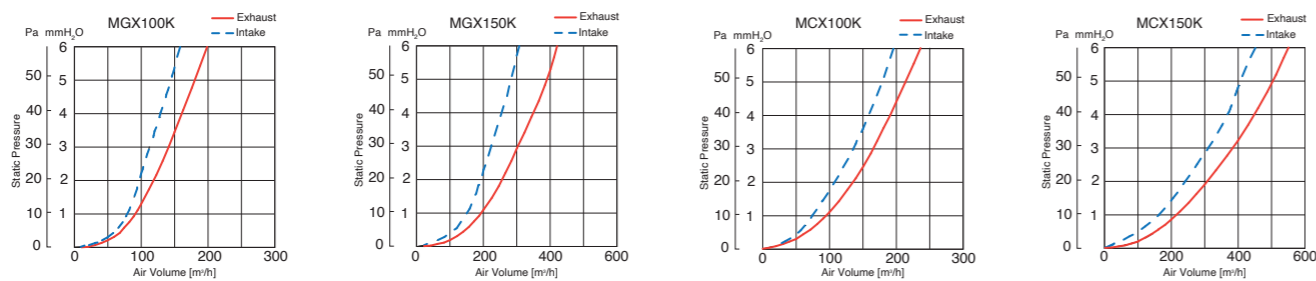

### Specification

Model	Diameter of Applicable Pipe [mm]	Material	Dimension of Net [mm]
MGX100K	100	Stainless Steel	2.5 x 2.5
MGX150K	150	Stainless Steel	2.5 x 2.5
MCX100K	100	Stainless Steel	-
MCX150K	150	Stainless Steel	-

# Accessories - Vent Cap

## VGX100K / VGX150K VCX100K / VCX150K

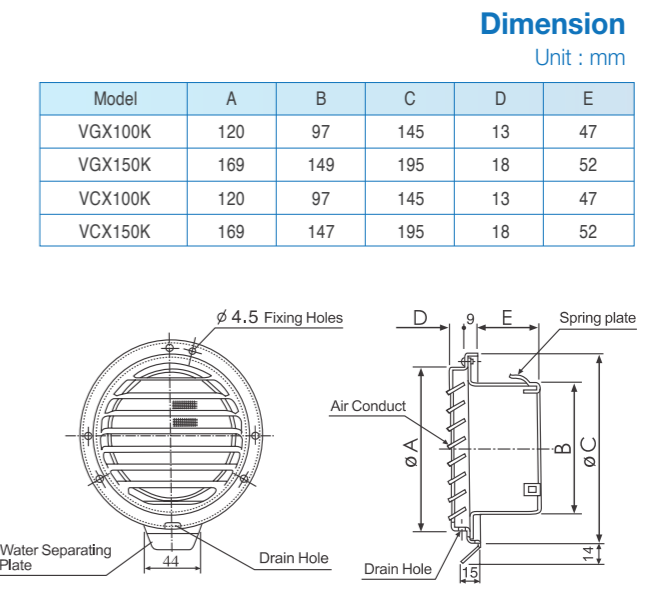

- High strength and excellent anti-rust capability - adopt 0.5mm thickness SUS 304 Stainless steel
- Easy installation - 3pcs of spring clip facilitate duct/pipe connection
- 2.5x2.5mm net keep out ingress of small particles and insects from outside (VGX100K & VGX150K)
- It is recommended to use pipe cap with net at intake terminal while with-out net at exhaust

### Performance Data

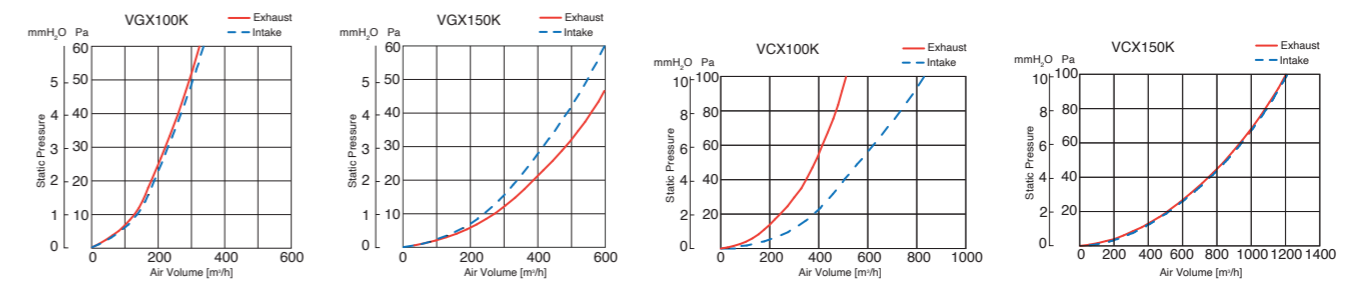

### Specification

Model	Diameter of Applicable Pipe [mm]	Material	Dimension of Net [mm]
VGX100K	100	Stainless Steel	2.5 x 2.5
VGX150K	150	Stainless Steel	2.5 x 2.5
VCX100K	100	Stainless Steel	-
VCX150K	150	Stainless Steel	-

# Energy Recovery Ventilator



24 Hours Ventilation



Energy Saving



Filtration



Powerful

# Energy Consumption Demand

There is a significant increase in the energy consumption demand globally, which is illustrated as in below charts.

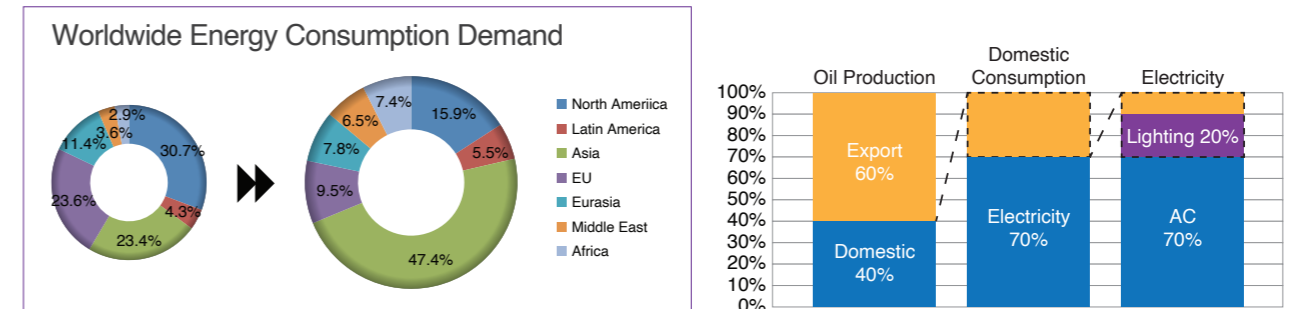

**Saudi Arabia**

- 2032: 17GW = 18-20% PGC
- 2032: 54.1GW (41GW Solar) (25GW CSP/16GW PV); 9GW wind; 4GW geothermal + waste-energy providing 23-30% PGC @ 150-190 TWh/y
- 2020: Bring energy intensity in line with G7 countries (SEEC)
- 2021: 14% electricity peak demand reduction, 8% consumption reduction (ECRA)

**Kuwait**

- 2015: 1% PGC
- 2030: 15% PGC

**Qatar**

- 2020: RE = 1.8GW
- 2017: 20% reduction in per capita electricity consumption and 35% reduction in per capita water consumption over 2011

**Abu Dhabi**

- 2012: Reduce electricity peak by 250MW
- 2020: 4 nuclear power plants (5.6GW) by 2020 providing 23-25% PGC
- 2020: 7% PGC
- Reduce electricity demand by 15% of 2010 demand by 2020

**Dubai**

- Reduce BAU projected power consumption by 30% by 2030
- 2030: 12% nuclear-powered electricity sourced from Abu Dhabi
- 2020: 1%
- 2030: 5%

**Bahrain**

- 2030: 5-7% PGC

**Oman**





- 2014: Reduce transmission and distribution losses in power sector from 14% in 2010 to 10%
- 2020: 10% PGC
- Electricity peak demand reduction target

**New Energy Saving Regulation** "World Top Regulation (EER > 9.5 at T1 condition)"

Y2013 Feb	: DEWA Gov. Announced New Regulation (From 2015)
Y2013 May	: Oil Gov. Announced to Move up the Schedule (From 2014)
(Phase-1)	
Y2013 Sep	: Banned to Import / Manufacture Non-Conformity Products
Y2014 Jan	: Banned to Import / Manufacture Non-Conformity Products
(Phase-2)	
Y2015 Jan	: Regulation becomes more strict (Required for EER>11.5)

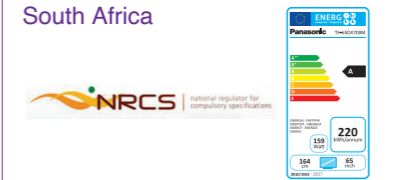
## Energy Saving Label Regulation

Significant energy saving could be achieved by using energy efficient appliances which help reducing the emission of greenhouse gases and other air pollutants from the power plants. To further facilitate the public in choosing energy efficient appliances and to raise public awareness on energy saving, Energy Labelling Schemes have been introduced.

<p><b>Jordan</b></p> 	<p><b>South Africa</b></p> 	<p><b>UAE</b></p> 
<p><b>Egypt</b></p> 	<p><b>Iran</b></p> 	<p><b>Saudi Arabia</b></p> 

Scan for more information



# Feature of Energy Recovery Ventilator

KDK Energy Recovery Ventilator is equipped with heat exchange core element. When outdoor fresh air and indoor foul air pass through the heat exchange core element, heat carried by the air is exchanged through air flow and heat conduction at the heat transfer sheets. Meanwhile, humidity exchange occurs from high humidity to low humidity as moisture is transferred due to the difference in pressure of water vapour.

## Energy Saving

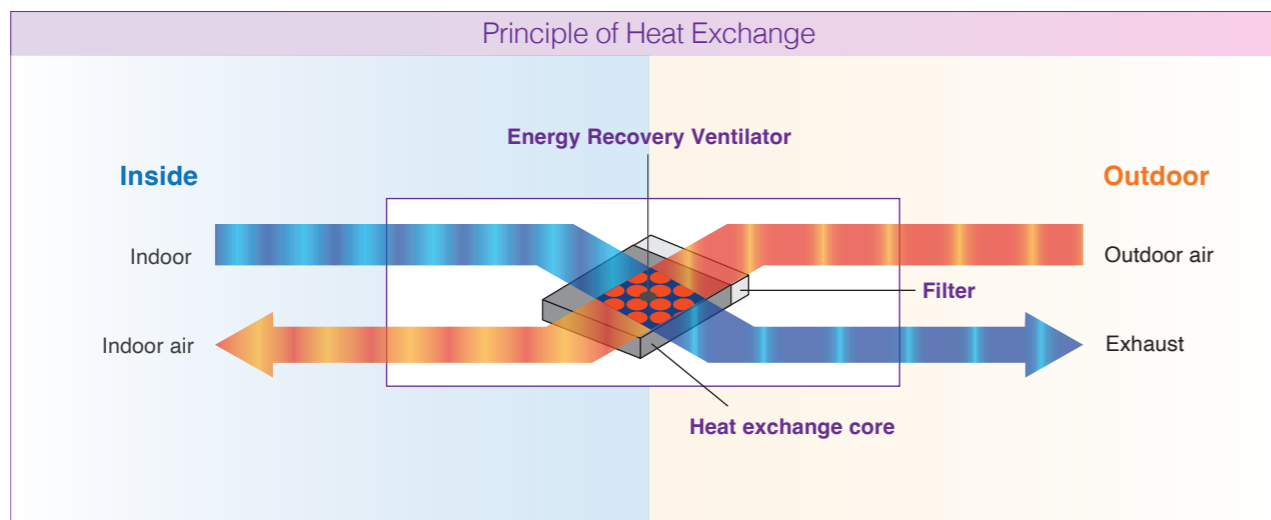
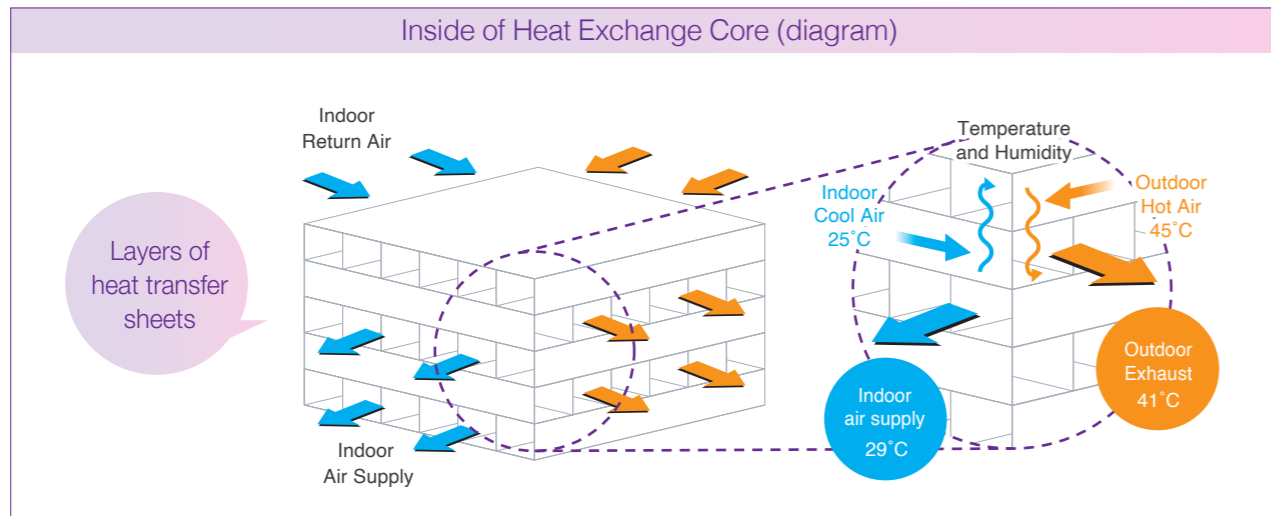

### Summer

In summer, the indoor cool air discharged can be used to precool outdoor warm air before it gets delivered indoor and so reduces the cooling effort.

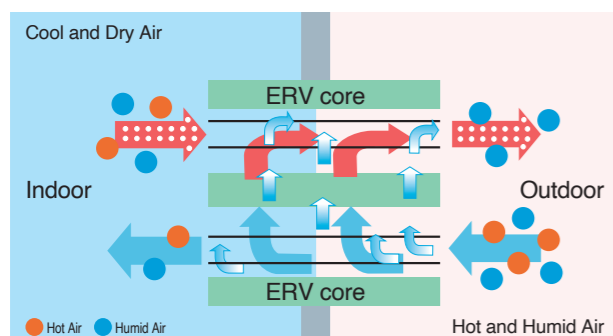

### Winter

Whereas in winter, indoor warm air discharged can be used to preheat outdoor cool air before it is released indoor and so saves some energy of heating.

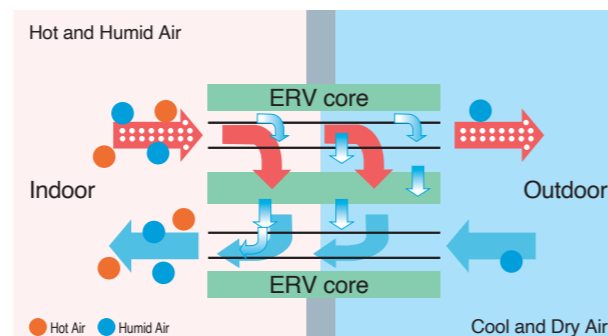

# Cost Efficient

Highly efficient energy recovery reduces energy loss during ventilation, and hence achieves energy saving.

## Long Term Energy Consumption Comparison

Comparison of the energy consumption over 180 days between using energy recovery ventilator and ventilating fan, in cooperation with air conditioning.

### Power Consumption of Fan and Air Conditioning

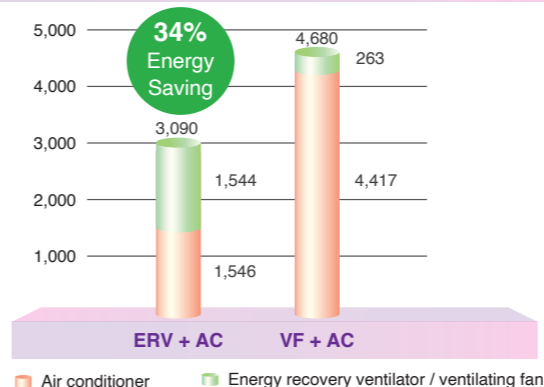

#### Based on the following condition

Simulation place: Aug Riyadh Saudi Arabia  
 Room Area = 210 m<sup>2</sup>  
 Room Height = 3 m  
 Required Air Volume = 315 CMH  
 A/C system running time : 2700h = 15h/day\*180day (May~Oct)  
 ERV : E35DZUA (2unit) 282W\*2 = 564W  
 V-Fan : General (6unit) 48W\*6 = 288W

**Summer** By utilizing the returned indoor cool air to cool down the outdoor air before it enters indoor, the indoor cooling cost can be reduced.

### Energy Recovery Ventilation + Air Conditioning

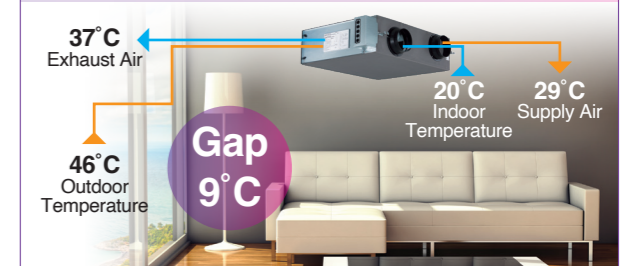

### Normal Ventilation + Air Conditioning



### Energy saving while holding down the air-conditioning cost



ERV can pre-cool (in summer) or pre-heat (in winter) the incoming air through the heat exchange mechanism with the outgoing air. This can largely save the cost of indoor air conditioning.

### Keeping comfortable indoor temperature regardless the condition outdoor



When it is cold outside, the incoming air is preheated by the outgoing warmed air before entering indoor.



When it is hot outside, the incoming air is pre-cooled by the outgoing cooled air before entering indoor.

### Aiding effective soundproof



Energy recovery ventilator operates in an airtight indoor environment while keeping high performance of ventilation. As a result, indoor sound like night music and video can be enjoyed without worrying sound leakage to the outside.



Likewise, airtight houses can effectively block the noise from outside entering indoor while energy recovery ventilator keeps up high performance of ventilation.

# Filter Box Specially for Middle East Region to Bring You Clean Air

KDK filter box is part of the ERV designed to make the indoor spaces insect free, dustproof and pollen free, such that fresh air can be circulated.

There are two filters, Primary Filter and PM2.5 Filter in one box. Incoming air firstly passes through Primary Filter which filters large particles like sand and insect. Then the tiny and invisible particles are further trapped by PM2.5 Filter. The ERV can bring you clean, fresh and comfortable air with these two layers of filters.

## Filter Box

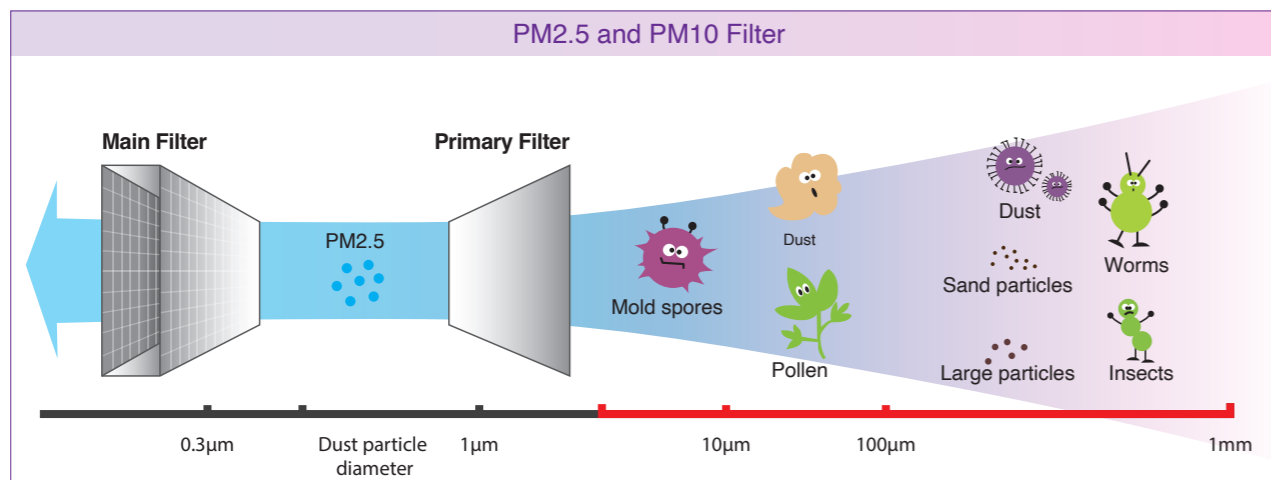
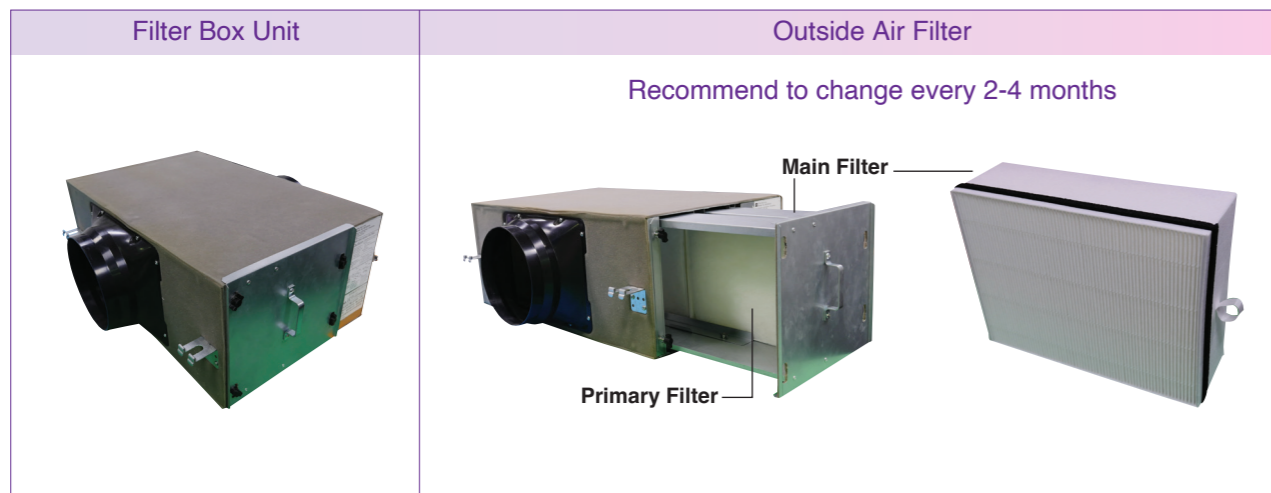

Filter Efficiency - Effectively capture PM2.5 and PM10 particles to deliver clean air to indoor

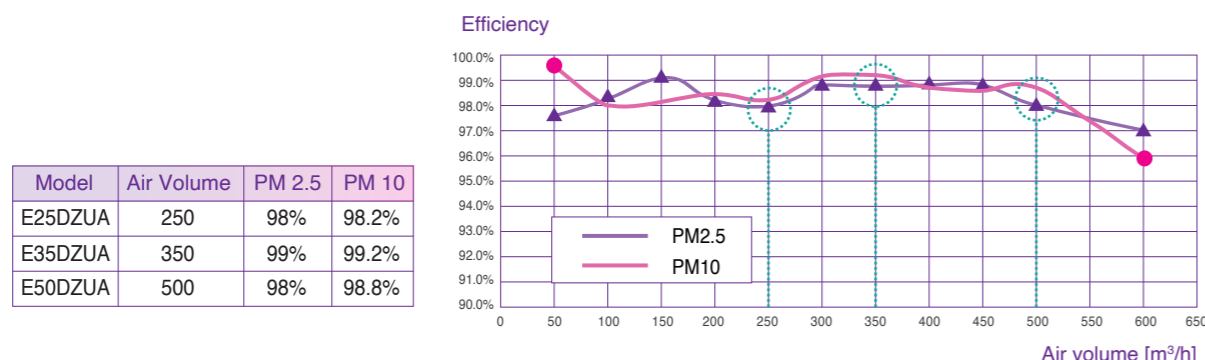

## Dust Polluted Air in Riyadh

Comparison of the particle size distribution of air dust (At a House in Riyadh)

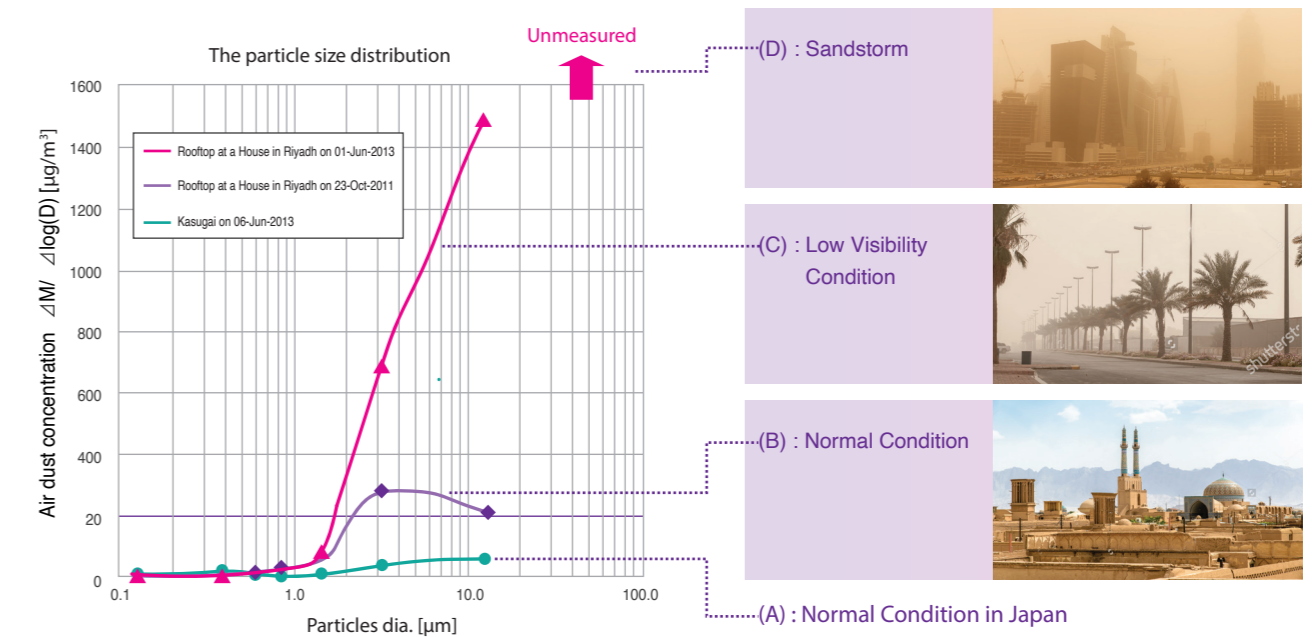

## Field test result in Saudi Arabia

Sand dust carries large number of 2-10 micrometre particles. KDK ERV is well equipped with filter box specially designed for Middle East environment.



## Ignition Loss Test\* result in Saudi Arabia

Large particle can be effectively trapped by the filter. There are many pollutants can be obtained by filters.

Filter Type	Collection amount (g)	Moisture (%)	Inorganic matter (%)
Standard Pre-filter	13.2	2.5	60.7
PM 2.5 Filter	2.5	3.0	61.7

\* Test Period: 2014/11/04~2014/12/15 Test Filter: FY-FBG25C

# Standard Series

Usage: Living Room Shopping Mall Office

## E25DZUA

- Energy Exchange
- Speedy Exhaust
- Interlocking with A/C

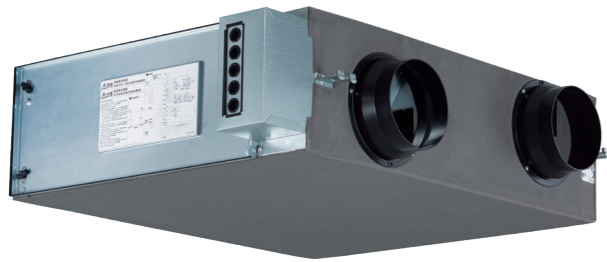

- Counter-flow heat-exchange element adopted for compact size
- Ease of maintenance through a single inspection hole
- Equipped with Extra-High setting
- Bypass ventilation for speedy exhaust
- Interlocking with air conditioning
- Motor insulation Class E
- IP protection: IPX2

KDK Company, Division of PES and Panasonic Ecology Systems Guangdong Co., Ltd. certify that the Energy Recovery Ventilator shown herein are licensed to bear the AMCA Seal. The ratings shown are based on tests and procedures performed in accordance with AMCA Publication 211 and AMCA Publication 311 and comply with the requirements of the AMCA Certified Ratings Program.

### Specification

Model	Voltage [V]	Frequency [Hz]	CFM / SONE AT STATIC Pressure (ps-inches of H <sub>2</sub> O)											RPM	Watts* FOR AMCA	Watts** FOR IEC		
			Inches of H <sub>2</sub> O		0	0.1	0.125	0.25	0.375	0.5	0.75	1	1.25				1.5	1.75
E25DZUA	220	60	CFM (OA-SA)		183	172	168	155	143	131	108	77	14	-	-	1,448	197	171
			CFM (RA-EA)		130	118	115.5	104	91	77	44	0	-	-	-	1,387	187	

Performance certified is for installation type D-Ducted inlet, Ducted outlet. Speed (RPM) shown is nominal. Performance is based on actual speed of test. Performance ratings do not include the effects of appurtenances (accessories).\*  
 Air performance ratings for gross supply airflow are from port 2. Air performance ratings for gross exhaust airflow are to port 3.  
 \* The Watts rating is only for AMCA test method and it is at the static pressure of 0 inch of H<sub>2</sub>O.  
 \*\* The Watts rating is only for IEC test method and AMCA Certified Rating Seal does not apply to IEC test method watts.

### Dimension Unit : mm

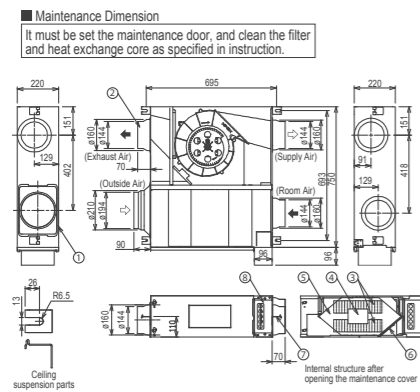

No.	Part name	Qty	Material
1	Frame	1	Galvanized Steel Sheet
2	Adapter	4	ABS
3	Impeller	2	PP
4	Fan Motor	1	/
5	Heat Exchange Core	1	Special Paper and Resin
6	Indoor Filter	1	/
7	Ceiling Suspension	4	Galvanized Steel Sheet
8	Switch Box	1	Galvanized Steel Sheet
9	Filter Box Unit	-	/

### Wiring Diagram

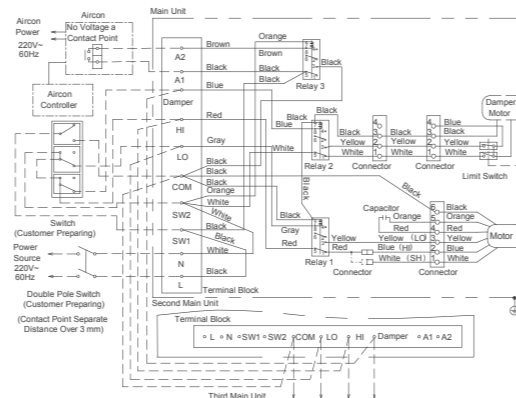

Installation method for case 1

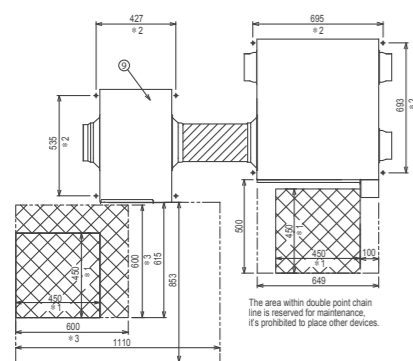

Installation method for case 2

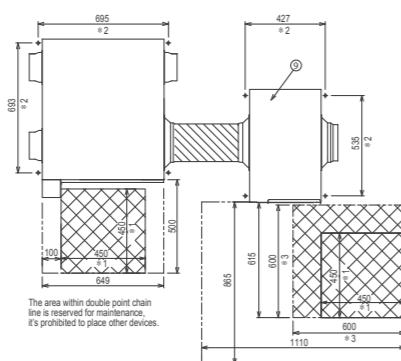

# Standard Series

Usage: Living Room Shopping Mall Office

## E35DZUA

- Energy Exchange
- Speedy Exhaust
- Interlocking with A/C

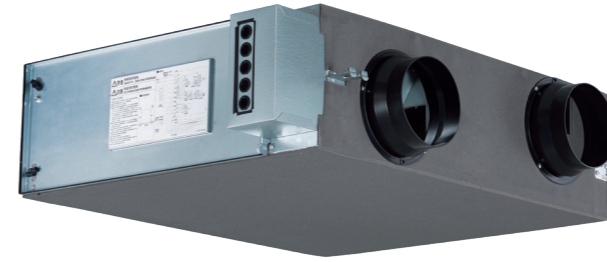

- Counter-flow heat-exchange element adopted for compact size
- Ease of maintenance through a single inspection hole
- Equipped with Extra-High setting
- Bypass ventilation for speedy exhaust
- Interlocking with air conditioning
- Motor insulation Class E
- IP protection: IPX2

KDK Company, Division of PES and Panasonic Ecology Systems Guangdong Co., Ltd. certify that the Energy Recovery Ventilator shown herein are licensed to bear the AMCA Seal. The ratings shown are based on tests and procedures performed in accordance with AMCA Publication 211 and AMCA Publication 311 and comply with the requirements of the AMCA Certified Ratings Program.

### Specification

Model	Voltage [V]	Frequency [Hz]	CFM / SONE AT STATIC Pressure (ps-inches of H <sub>2</sub> O)											RPM	Watts* FOR AMCA	Watts** FOR IEC		
			Inches of H <sub>2</sub> O		0	0.1	0.125	0.25	0.375	0.5	0.75	1	1.25				1.5	1.75
E35DZUA	220	60	CFM (OA-SA)		258	250	247	237	225	211	174	144	118	69	-	1,425	348	310
			CFM (RA-EA)		192	183	180	169	157	144	116	84	49	0	-	1,402	342	

Performance certified is for installation type D-Ducted inlet, Ducted outlet. Speed (RPM) shown is nominal. Performance is based on actual speed of test. Performance ratings do not include the effects of appurtenances (accessories).\*  
 Air performance ratings for gross supply airflow are from port 2. Air performance ratings for gross exhaust airflow are to port 3.  
 \* The Watts rating is only for AMCA test method and it is at the static pressure of 0 inch of H<sub>2</sub>O.  
 \*\* The Watts rating is only for IEC test method and AMCA Certified Rating Seal does not apply to IEC test method watts.

### Dimension Unit : mm

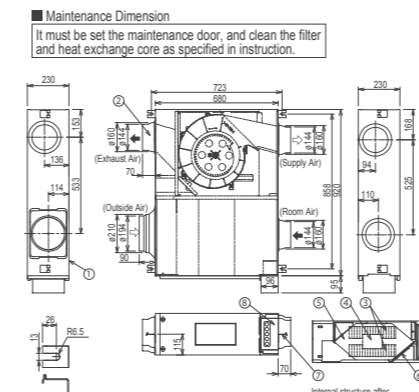

No.	Part name	Qty	Material
1	Frame	1	Galvanized Steel Sheet
2	Adapter	4	ABS
3	Impeller	2	PP
4	Fan Motor	1	/
5	Heat Exchange Core	1	Special Paper and Resin
6	Indoor Filter	1	/
7	Ceiling Suspension	4	Galvanized Steel Sheet
8	Switch Box	1	Galvanized Steel Sheet
9	Filter Box Unit	-	/

### Wiring Diagram

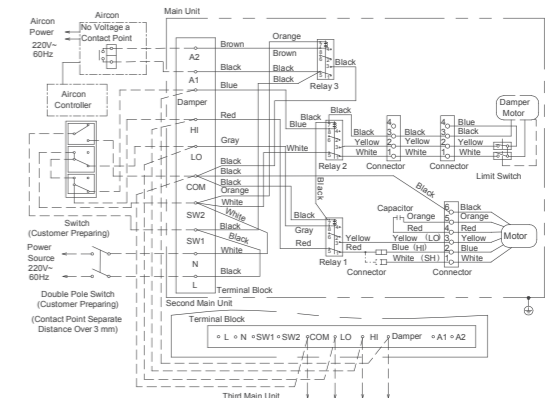

Installation method for case 1

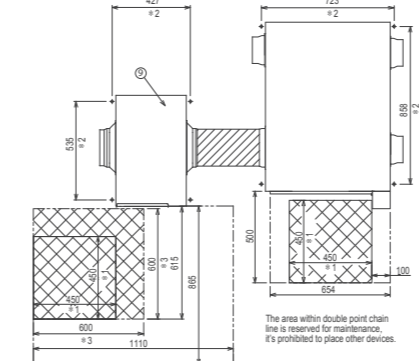

Installation method for case 2

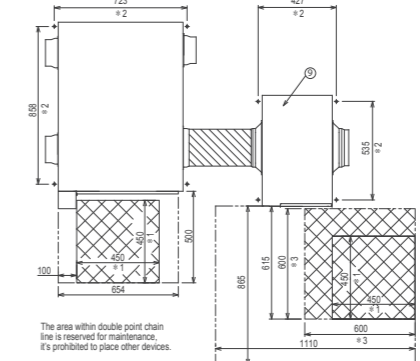

# Standard Series

Usage: Living Room Shopping Mall Office

## E50DZUA

- Energy Exchange
- Speedy Exhaust
- Interlocking with A/C

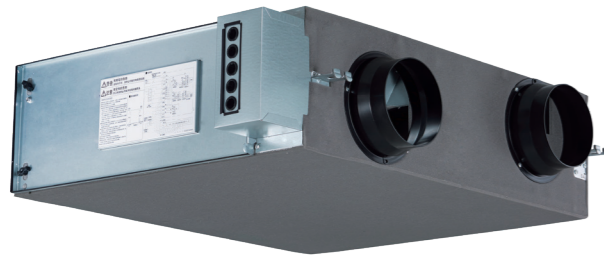

- Counter-flow heat-exchange element adopted for compact size
- Ease of maintenance through a single inspection hole
- Equipped with Extra-High setting
- Bypass ventilation for speedy exhaust
- Interlocking with air conditioning
- Motor insulation Class E
- IP protection: IPX2

KDK Company, Division of PES and Panasonic Ecology Systems Guangdong Co., Ltd. certify that the Energy Recovery Ventilator shown herein are licensed to bear the AMCA Seal. The ratings shown are based on tests and procedures performed in accordance with AMCA Publication 211 and AMCA Publication 311 and comply with the requirements of the AMCA Certified Ratings Program.

### Specification

Model	Voltage [V]	Frequency [Hz]	CFM / SONE AT STATIC Pressure (ps-inches of H <sub>2</sub> O)													RPM	Watts* FOR AMCA	Watts** FOR IEC
			Inches of H <sub>2</sub> O	0	0.1	0.125	0.25	0.375	0.5	0.75	1	1.25	1.5	1.75				
E50DZUA	220	60	CFM (OA-SA)	339	330	326	314	303	290	261	230	188	134	80	1,501	470	406	
			CFM (RA-EA)	253	241	238	224	207	190	154	117	82	41	-	1,452			

Performance certified is for installation type D-Ducted inlet, Ducted outlet. Speed (RPM) shown is nominal. Performance is based on actual speed of test. Performance ratings do not include the effects of appurtenances (accessories).\*  
 Air performance ratings for gross supply airflow are from port 2. Air performance ratings for gross exhaust airflow are to port 3.  
 \* The Watts rating is only for AMCA test method and it is at the static pressure of 0 inch of H<sub>2</sub>O.  
 \*\* The Watts rating is only for IEC test method and AMCA Certified Rating Seal does not apply to IEC test method watts.

### Dimension Unit : mm

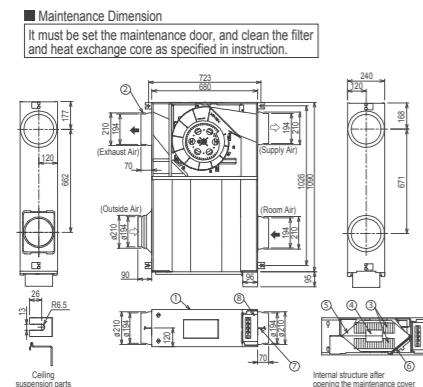

No.	Part name	Qty	Material
1	Frame	1	Galvanized Steel Sheet
2	Adapter	4	ABS
3	Impeller	2	PP
4	Fan Motor	1	/
5	Heat Exchange Core	2	Special Paper and Resin
6	Indoor Filter	1	/
7	Ceiling Suspension	4	Galvanized Steel Sheet
8	Switch Box	1	Galvanized Steel Sheet
9	Filter Box Unit	-	/

### Wiring Diagram

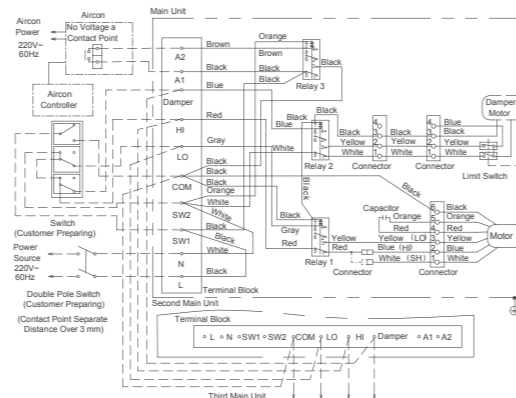

#### Installation method for case 1

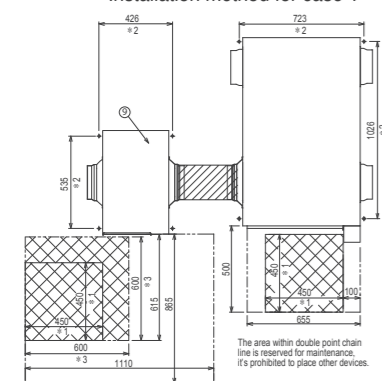

#### Installation method for case 2

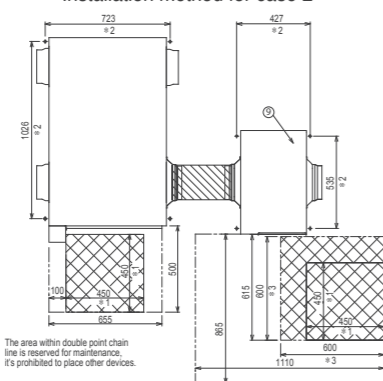

# Accessory

## EB90SA (Applicable to series DZUA)

- Power : 220V / 60Hz
- Rate voltage : 3.6W
- Outer size : 86x86x40mm



## Filter Box Unit

### BE25DZUA For E25DZUA, E35DZUA

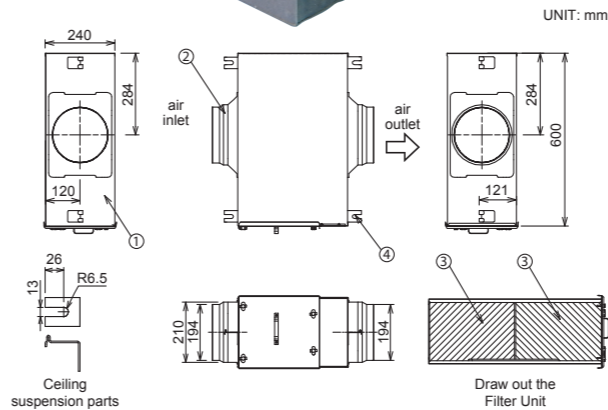
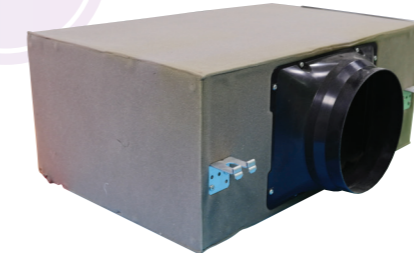

No.	Part name	Qty	Material
1	Frame	1	Galvanized Steel Sheet
2	Adapter	2	ABS
3	Outdoor filter	2	Nonwoven Fabric
4	Ceiling Suspension	4	Galvanized Steel Sheet

### BE50DZUA For E50DZUA

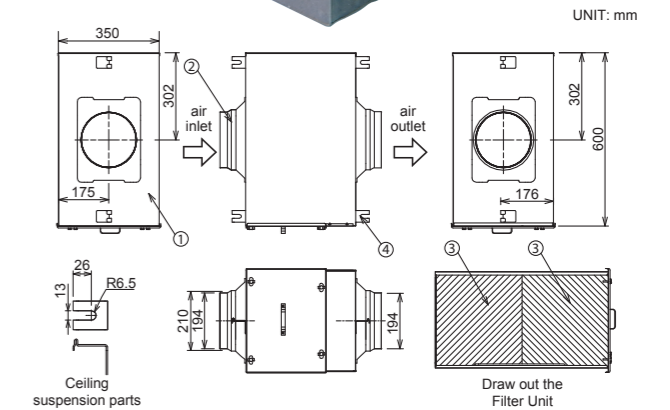
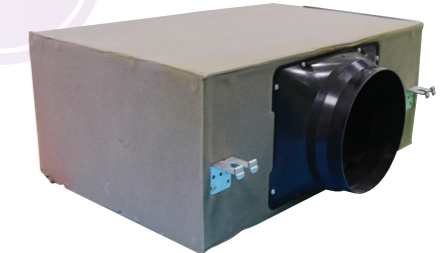

No.	Part name	Qty	Material
1	Frame	1	Galvanized Steel Sheet
2	Adapter	2	ABS
3	Outdoor filter	2	Nonwoven Fabric
4	Ceiling Suspension	4	Galvanized Steel Sheet

## Replacement Filter

Product name	Filter Model	Filter(s) Included	Applicable Model	Service life of the filter	Remarks
Replacement filter for Filter Box Unit	FP25DZUA	2	BE25DZUA	2-4 months	Clean monthly
	FP50DZUA	2	BE50DZUA		
Replacement filter for ERV	FB25DZUA	1	E25DZUA	6 months	
	FB35DZUA	1	E35DZUA		
	FB50DZUA	1	E50DZUA		

\* The service life of the filters varies with service environment, and the filters should be replaced with the new one.  
 \* The air volume and filter efficiency will drop to different levels because of different service environments and service time. If the whole area indicated by the arrow turns black, please replace the filter.

# Thermo Ventilator

# Feature of Thermo Ventilator



Ventilation



Circulation



Heating



Clothes Drying

## Multi-functional

**Ventilation** - Exhaust foul smell and excessive moisture

**Circulation** - Provide circulation of air to avoid uncomfortable feeling due to stagnant air

**Heating** - Warm up the room for pleasant bathing

**Clothes Drying** - Enable to dry large sized garments and bedclothes.



Ventilation



Circulation

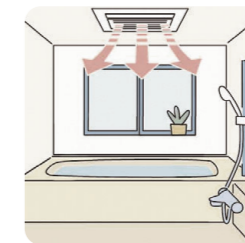

Heating



Clothes Drying

## Remote Control

All functions can be operated through wireless remote control.

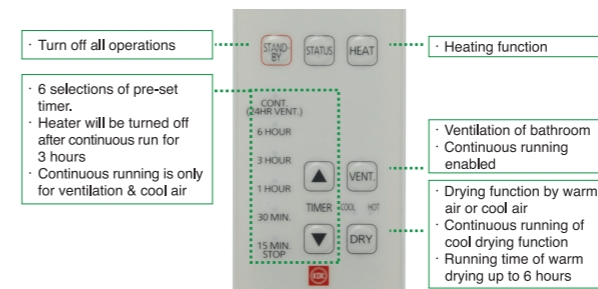

## Filter Equipped

Equipped with dust filter to trap the dust.



## Safety Protection

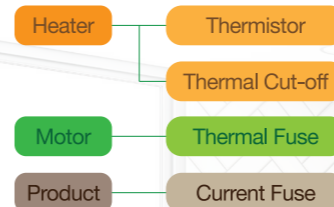

Multi-level safety structure protects you and your property from any accidents

## Easy Installation

Specially designed compact size allows easy installation on most households' ceilings.

Structure is improved for easy wiring as compared with previous model.



Scan for more information



# Ceiling Mount Series

Usage: Bathroom Toilet

## 30BUC

- Multi-functional
- Wireless Remote
- Compact Design



- Multi-function: Ventilation, Circulation, Heating and Clothes Drying
- PTC heating element for effective heating
- Multi-level safety protection
- 5-step off timer
- Motor insulation Class E
- IP protection: IPX2

### Dimension Unit : mm

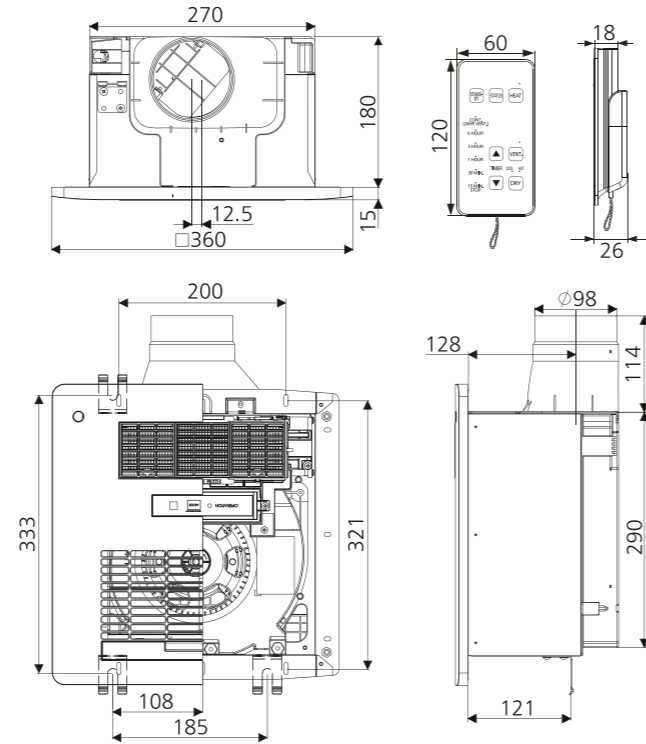

### Specification

Model	Voltage		Air Volume		Consumption [W]				Noise [dB(A)]				Weight [kg]	Installation Space [mm]
	[V]	[Hz]	[CMH]	[CFM]	Heat	Vent	Dry Cool	Dry Hot	Heat	Vent	Dry Cool	Dry Hot		
30BUC	220	60	160	95	1,650	24	33	1,550	46	39	46	46	5.0	300 x 300

#### Test Condition

- Air volume, electric characteristic and noise are specified at the static pressure of 0 Pa
- The values of noise level is A weighted average sound pressure level, the mean values are measured by our company, within +3 to -7 dB tolerance
- The values of noise level are measured at 1 m apart from the side of fan body when ducts are connected on outlet side
- The values of air volume are the mid-points of results measured by our company, within ±10% tolerance

### Performance Data

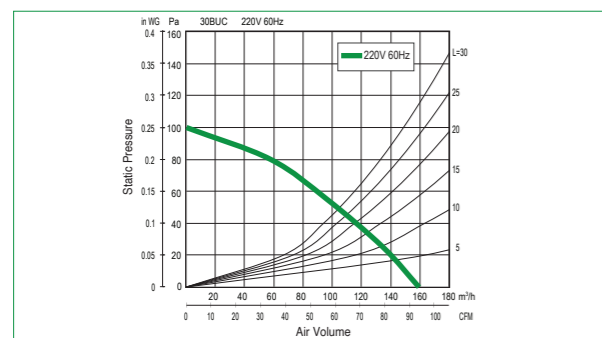

### Wiring Diagram

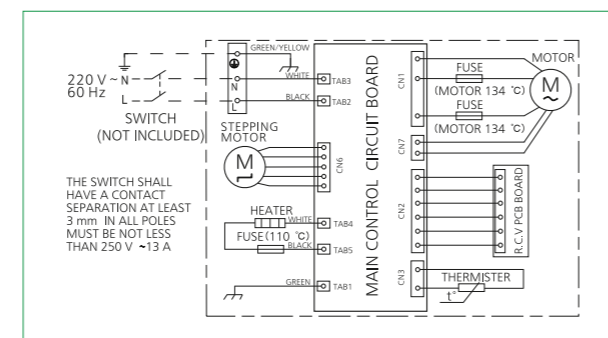

# Range Hood



Powerful



Easy to Clean

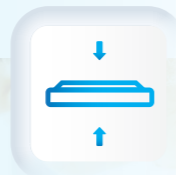

Slim Design

# Feature of Range Hood

## Sirocco Fan

The adopted sirocco fans can outperform the turbo fans while keeping the noise level low.

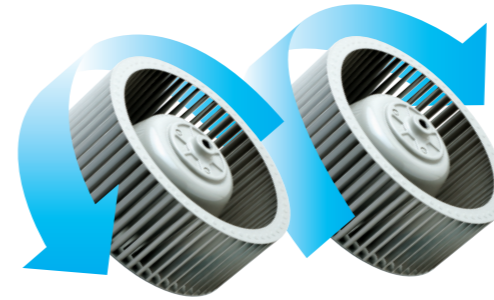

A typical range hood installation involves a long duct with at least one bending like the diagram below. Under a condition of adopting 1.5m long duct with a grille that results a static pressure of 80Pa, KDK range hood's air volume can reach 580 m<sup>3</sup>/h at Point C while some other brands can only reach 530 m<sup>3</sup>/h at Point D as illustrated in the graph on the left.

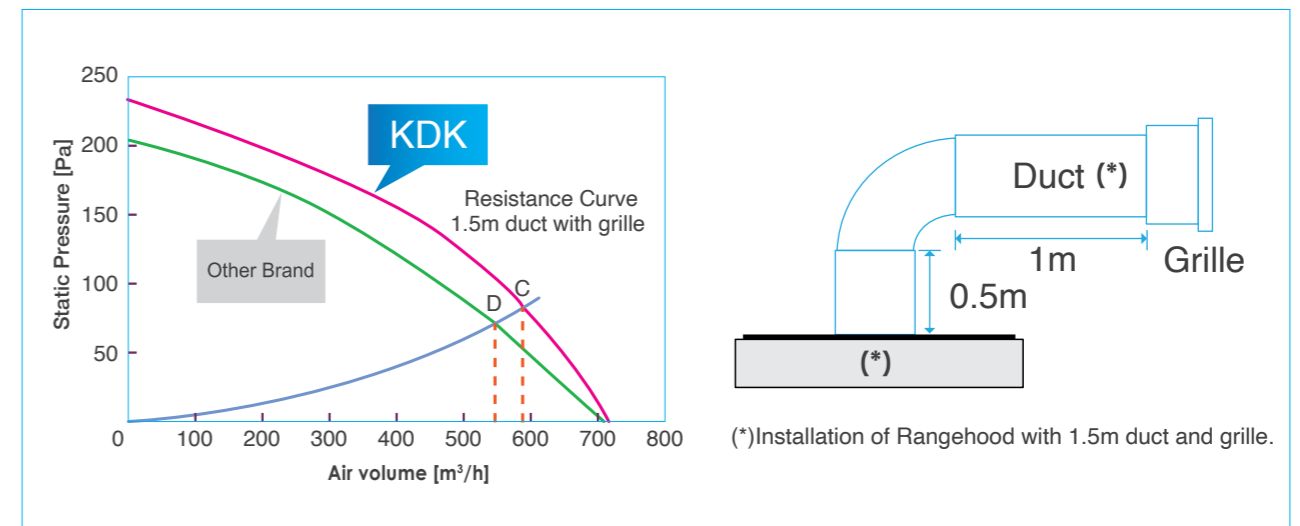

## Example

Comparison of Suction Power	Air Volume [m <sup>3</sup> /h]								
	without duct	5m duct		10m duct		15m duct		*1.5m duct grille	
KDK	720	650	89%	610	84%	560	77%	580 (C)	79%
Other Brand	720	610	85%	540	75%	480	67%	530 (D)	74%

Scan for more information



# Ceiling Mount Series

Usage: **Kitchen**

## 90HQUA

2-Speed Selection

Easy Maintenance

Slim Design



Dark Gray



Silver

- 2 motors with 2 sirocco fans adopted
- Individual control of motors with 2-speed selection
- Rocker switch
- Easy detachable for cleaning
- Slim designed main body with only 115mm thickness
- Colour option: silver / dark gray
- Motor insulation Class E

### Dimension

Unit : mm

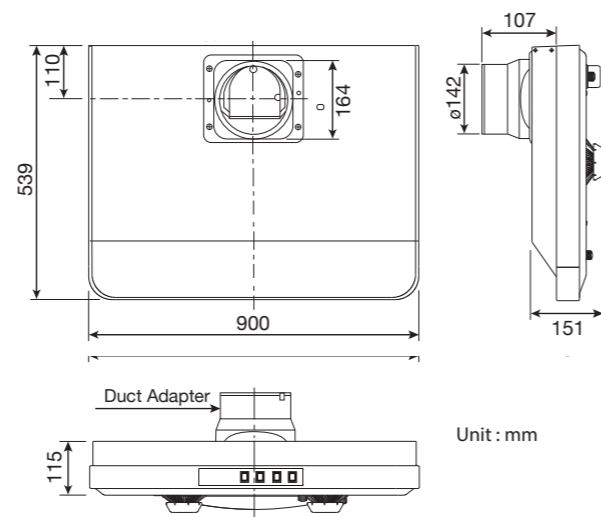

Unit : mm



Rocker Switch

### Specification

Model	Voltage			Air Volume		Consumption [W]	RPM	Noise [dB(A)]	Weight [kg]	Duct Size [mm]
	[V]	[Hz]		[CMH]	[CFM]					
90HQUA	220	50	Hi	785	462	152	993	52	18.0	Ø150
			Lo	484	285	75	570	38		
		60	Hi	779	459	127	905	53		
			Lo	464	273	69	594	41		
	240	50	Hi	775	456	136	911	52.7		
			Lo	523	308	80	653	43		

#### Test Condition

- Air volume, electric characteristic and noise are specified at the static pressure of 0 Pa
- The values of noise level is A weighted average sound pressure level, the mean values are measured by our company, within +3 to -7 dB tolerance
- The values of noise level are measured at 1 m apart from the side of fan body when ducts are connected on outlet side
- The values of air volume are the mid-points of results measured by our company, within ±10% tolerance

### Performance Data

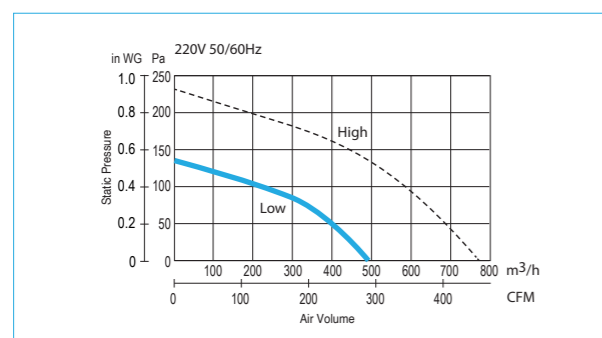

### Wiring Diagram

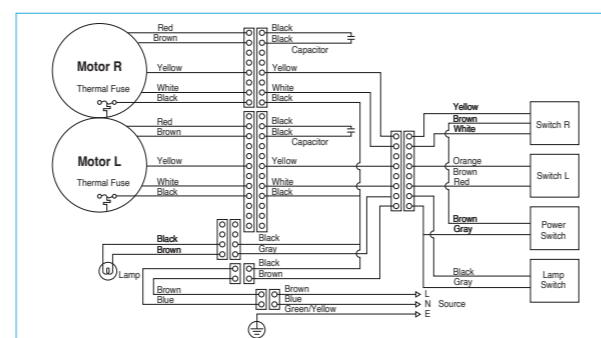

# Hand Dryer



Quick Drying



Anti-bacterial



Safe



Scan for more information



# Feature of Hand Dryer



### Safe Operation

- Eco Dry will stop after 60 seconds of continuous operation
- "Check" indicator will light up when the unit detects overheated

### Quick Response Sensor

Automatic sensor operation, no physical contact is required to activate the unit

### Heater ON/OFF Switch

Heater can be switched off for energy saving in hot season

## Quick Drying with 3-way Airflow



### Wide Nozzle

Blow off water droplets on the whole palm with wide airflow

### Spot Nozzle

Dry fine water droplets by rubbing hands with spot airflow

2 kinds of nozzle, wide nozzle and spot nozzle, are equipped at front and rear of drying chamber respectively for efficient drying. The structure realizes quick drying in only 4-9 seconds



## Super Alleru-buster Filter

The filter is equipped to ensure the air blow to your hand is clean

### Anti-bacteria Material as it is installed

The product body is adopted with anti-bacteria material to prevent the growth of bacteria and germs in the warm and humid environment of wash-room

(T09AC only)

### Drain Pan

Drain pan can reduce water dripping on the floor to avoid slippery



## What is Super alleru-buster?

Super alleru-buster can inhibit up to several types of allergen

Phenolic Polymer • Polyphenol

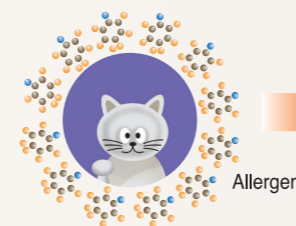

Allergen

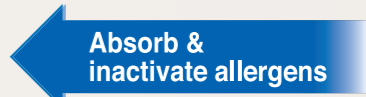
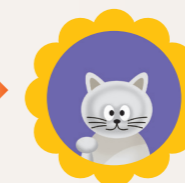

Absorb & inactivate allergens

### Full Tank Indicator

Remind you for cleaning up

Testing Organization: The Osaka Municipal Technical Research Institute.

Testing Method: To measure the level of reduction in cat's dandruff by Enzyme-linked Immuno Sorbent Assay.

# Standard Series

Usage: Toilet

## T09AC / T09BC

Anti-bacterial Body

Auto Sensor

IPX1 Protection



### Dimension Unit : mm

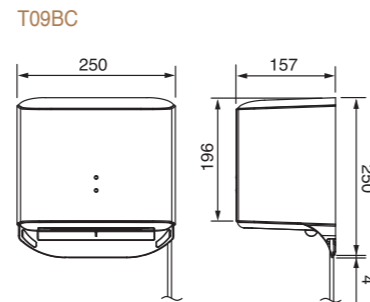
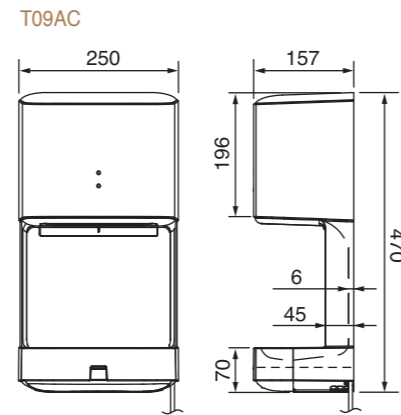

- Powerful air velocity
- Automatic operation by infra-red motion sensor
- Super alleru-buster filter equipped
- Anti-bacteria material used on product body
- ON/OFF switch for heater
- Safety check indicator
- Auto stop after 60 seconds of continuous operation
- Motor insulation Class E
- IP protection: IPX1
- T09AC only: Drain pan and water tank equipped with full tank indicator

### Specification

Model	Voltage		Consumption [W]		Air Velocity [m/s]	Noise [dB(A)]	Weight [kg]
	[V]	[Hz]	Heater ON	Heater OFF			
T09AC	220	50/60	1,020	650	90-110	62	4.0
	230		1,070	700			
T09BC	220	50/60	1,020	650	90-110	62	3.5
	230		1,070	700			

### Wiring Diagram

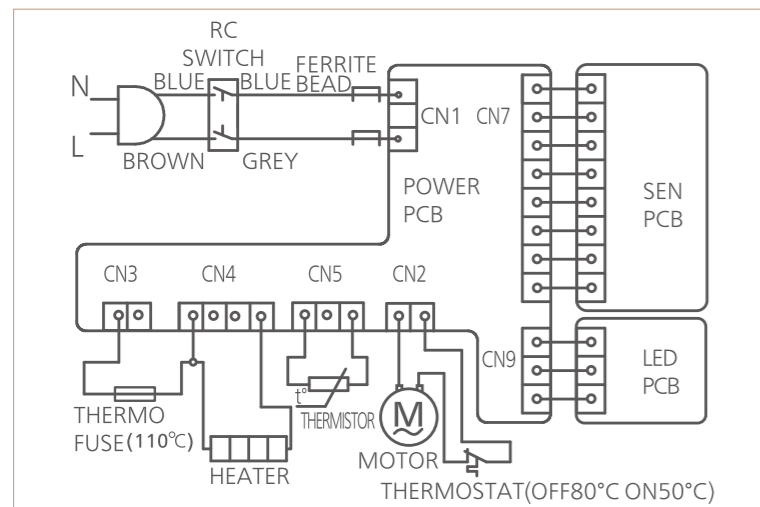

# Air Curtain



Effective



Durable



Easy Maintenance



Scan for more information



# Feature of Cross Flow Type Air Curtain

## Efficient Barrier Effect

- The Cross Flow Fan enables wide and uniform airflow distribution while keeping up the required air volume at a low noise level.
- Unique Auxiliary Air Inlet allows more air intake at lower front that enhances airflow output.

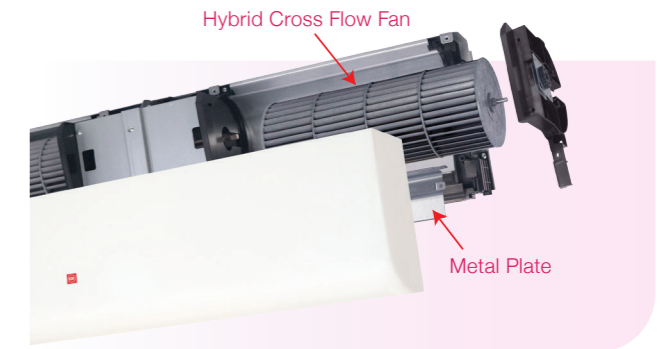

## Highly Durable

- Resin with glass fiber material is used in the Hybrid Cross Flow Fan.
- Incorporated with the metal bush, the durability is prolonged significantly.

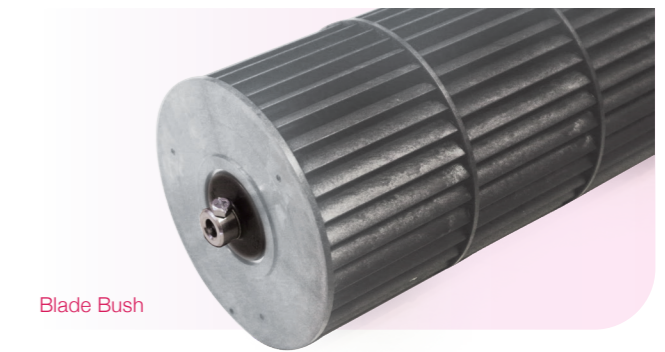

Blade Bush

## Easy Maintenance

- The Cross Flow Fan can generate air current between the fan and front cover. It forms the movement of dust that reduces dust accumulation on the fan blade.
- Simple structure allows convenient cleaning of the fan – just detach the front cover and metal plate to clean product interior.

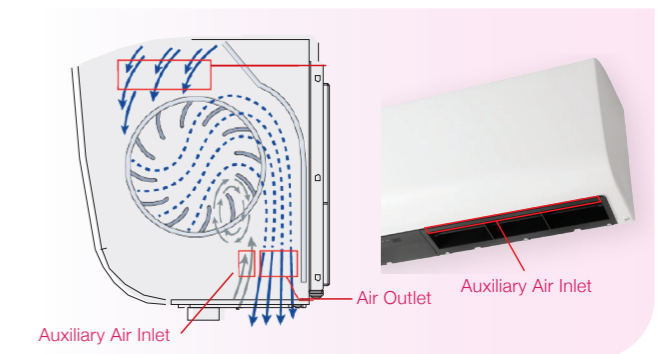

Auxiliary Air Inlet

Air Outlet

Auxiliary Air Inlet

## Contemporary Design

Its modern and sleek outlook with the air inlet on top well fits to the contemporary interior, delivering a clean and neat image.

## Convenient Control

- For remote controlled series, Stand-by and Hi/Lo speed can be simply switched by handheld remote control.
- For sensor series, it operates when the door is sensed open. It then automatically stops after 10 seconds once the door is sensed closed.

# Cross Flow Type - Remote Control Series

Usage: Shopping Mall Retail Store

3009GA / 3012GA / 3015GA  
4009GA / 4012GA / 4015GA

Wide and Uniform Airflow

Resin with Glass Fibre Fan Blade

2-speed Selection



Model	Dimension Unit : mm		
	3009GA 4009GA	3012GA 4012GA	3015GA 4015GA
A	900	1,200	1,500
B	50	200	350

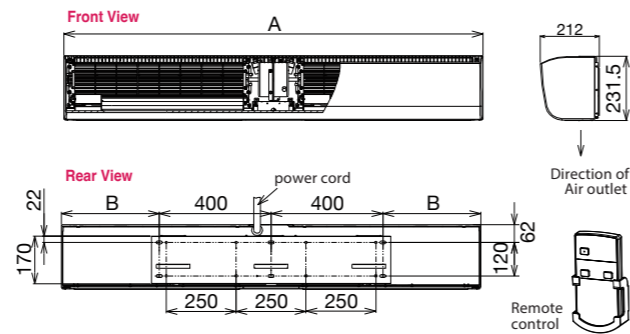

Wiring Diagram

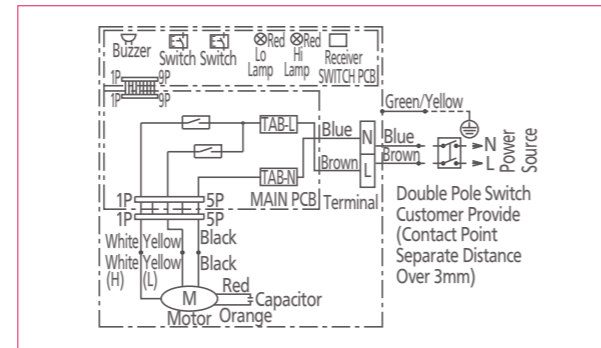

- Cross flow fan adopted for side and uniform airflow
- Thick air stream to provide high airflow momentum
- Fan blade made of resin with glass fibre and metal bush
- Permanently-lubricated ball bearing equipped
- Air deflection plate for airflow direction adjustment
- Soft touch switch panel with 2-speed selection
- Motor insulation Class B (4015GA: F)

## Specification

Model	Voltage			Air Volume		Consumption [W]	Current [A]	Outlet Velocity [m/s]	Noise [dB(A)]	Weight [kg]
	[V]	[Hz]		[CMH]	[CFM]					
3009GA	220	50	Hi	1,100	647	76	0.35	10.5	48.5	12.5
			Lo	920	541	70	0.32	8.5	45.0	
		60	Hi	1,100	647	92	0.42	10.5	49.5	
	240	50	Lo	900	530	78	0.36	8.5	45.0	
			Hi	1,150	677	86	0.37	10.5	50.5	
		60	Lo	960	565	80	0.35	9.0	47.5	
4009GA	220	50	Hi	1,340	789	110	0.50	12.0	54.5	13.5
			Lo	1,190	700	94	0.43	10.0	51.0	
		60	Hi	1,340	789	141	0.64	12.0	55.5	
	240	50	Lo	1,100	647	111	0.51	10.0	51.0	
			Hi	1,360	800	122	0.51	12.5	56.5	
		60	Lo	1,200	706	100	0.43	11.0	53.5	
3012GA	220	50	Hi	1,400	824	94	0.43	9.5	48.5	15.0
			Lo	1,270	747	85	0.40	8.0	45.0	
		60	Hi	1,400	824	109	0.51	9.5	48.5	
	240	50	Lo	1,250	736	94	0.46	8.0	45.0	
			Hi	1,500	883	107	0.46	10.0	50.5	
		60	Lo	1,320	777	95	0.43	9.0	47.0	
4012GA	220	50	Hi	1,700	1,001	126	0.59	12.0	52.5	16.0
			Lo	1,530	901	105	0.49	10.0	49.0	
		60	Hi	1,700	1,001	153	0.70	12.0	52.5	
	240	50	Lo	1,450	853	118	0.55	10.0	49.0	
			Hi	1,800	1,059	139	0.60	12.5	54.5	
		60	Lo	1,580	930	110	0.49	11.0	51.0	
3015GA	220	50	Hi	2,000	1,177	131	0.59	10.5	51.5	18.5
			Lo	1,800	1,059	110	0.50	9.5	48.0	
		60	Hi	2,000	1,177	150	0.68	10.5	51.5	
	240	50	Lo	1,750	1,030	118	0.54	9.5	48.0	
			Hi	2,100	1,236	145	0.60	11.0	53.5	
		60	Lo	1,850	1,089	115	0.50	10.0	50.5	
4015GA	220	50	Hi	2,450	1,442	177	0.81	13.0	56.0	18.5
			Lo	2,000	1,177	147	0.68	10.0	52.0	
		60	Hi	2,300	1,354	220	1.01	13.0	56.0	
	240	50	Lo	1,780	1,048	160	0.74	9.5	52.0	
			Hi	2,500	1,471	200	0.86	13.5	58.0	
		60	Lo	2,050	1,207	160	0.68	11.0	54.5	

Test Condition

Note : The parameters shown above are measured at ambient temperature of 20°C  
- The values of noise level are measured at 1.5 m apart from the product at angle of 45° below the air outlet at which is the maximum value  
- The velocity is measured in test laboratory. It may vary depends on different environment in actual usage

# Cross Flow Type - Sensor Series

Usage: Shopping Mall Retail Store

3009DA / 3012DA / 3015DA  
4009DA / 4012DA / 4015DA

Wide and Uniform Airflow

Resin with Glass Fibre Fan Blade

2-speed Selection



Model	Dimension Unit : mm		
	3009DA 4009DA	3012DA 4012DA	3015DA 4015DA
A	900	1,200	1,500
B	50	200	350

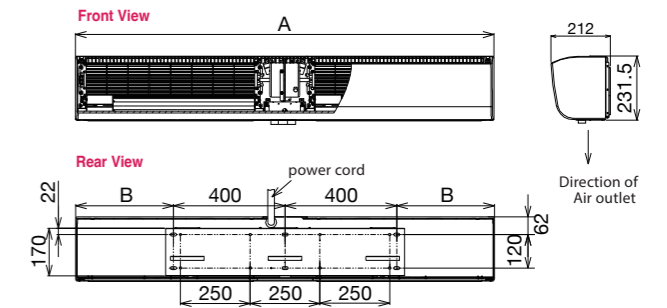

Wiring Diagram

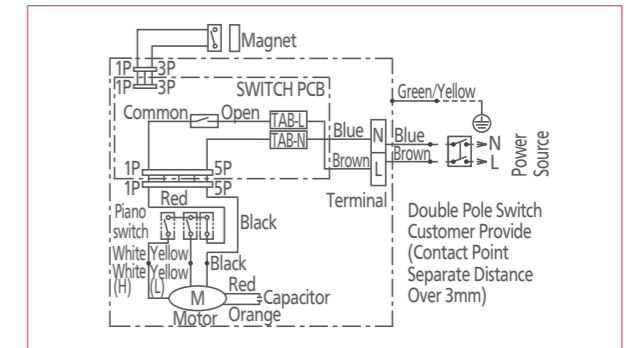

- Cross flow fan adopted for side and uniform airflow
- Thick air stream to provide high airflow momentum
- Fan blade made of resin with glass fibre and metal bush
- Permanently-lubricated ball bearing equipped
- Air deflection plate for airflow direction adjustment
- Soft touch switch panel with 2-speed selection
- Motor insulation Class B (4015DA: F)

## Specification

Model	Voltage			Air Volume		Consumption [W]	Current [A]	Outlet Velocity [m/s]	Noise [dB(A)]	Weight [kg]
	[V]	[Hz]		[CMH]	[CFM]					
3009DA	220	50	Hi	1,100	647	76	0.35	10.5	48.5	12.5
			Lo	920	541	70	0.32	8.5	45.0	
		60	Hi	1,100	647	92	0.42	10.5	49.5	
	240	50	Lo	900	530	78	0.36	8.5	45.0	
			Hi	1,150	677	86	0.37	10.5	50.5	
		60	Lo	960	565	80	0.35	9.0	47.5	
4009DA	220	50	Hi	1,340	789	110	0.50	12.0	54.5	13.5
			Lo	1,190	700	94	0.43	10.0	51.0	
		60	Hi	1,340	789	141	0.64	12.0	55.5	
	240	50	Lo	1,100	647	111	0.51	10.0	51.0	
			Hi	1,360	800	122	0.51	12.5	56.5	
		60	Lo	1,200	706	100	0.43	11.0	53.5	
3012DA	220	50	Hi	1,400	824	94	0.43	9.5	48.5	15.0
			Lo	1,270	747	85	0.40	8.0	45.0	
		60	Hi	1,400	824	109	0.51	9.5	48.5	
	240	50	Lo	1,250	736	94	0.46	8.0	45.0	
			Hi	1,500	883	107	0.46	10.0	50.5	
		60	Lo	1,320	777	95	0.43	9.0	47.0	
4012DA	220	50	Hi	1,700	1,001	126	0.59	12.0	52.5	16.0
			Lo	1,530	901	105	0.49	10.0	49.0	
		60	Hi	1,700	1,001	153	0.70	12.0	52.5	
	240	50	Lo	1,450	853	118	0.55	10.0	49.0	
			Hi	1,800	1,059	139	0.60	12.5	54.5	
		60	Lo	1,580	930	110	0.49	11.0	51.0	
3015DA	220	50	Hi	2,000	1,177	131	0.59	10.5	51.5	18.5
			Lo	1,800	1,059	110	0.50	9.5	48.0	
		60	Hi	2,000	1,177	150	0.68	10.5	51.5	
	240	50	Lo	1,750	1,030	118	0.54	9.5	48.0	
			Hi	2,100	1,236	145	0.60	11.0	53.5	
		60	Lo	1,850	1,089	115	0.50	10.0	50.5	
4015DA	220	50	Hi	2,450	1,442	177	0.81	13.0	56.0	18.5
			Lo	2,000	1,177	147	0.68	10.0	52.0	
		60	Hi	2,300	1,354	220	1.01	13.0	56.0	
	240	50	Lo	1,780	1,048	160	0.74	9.5	52.0	
			Hi	2,500	1,471	200	0.86	13.5	58.0	
		60	Lo	2,050	1,207	160	0.68	11.0	54.5	

Test Condition

Note : The parameters shown above are measured at ambient temperature of 20°C  
- The values of noise level are measured at 1.5 m apart from the product at angle of 45° below the air outlet at which is the maximum value  
- The velocity is measured in test laboratory. It may vary depends on different environment in actual usage

# Cross Flow Type - Standard Series

Usage: Shopping Mall Retail Store

3009UA / 3012UA / 3015UA  
4009UA / 4012UA / 4015UA

- Wide and Uniform Airflow
- Resin with Glass Fibre Fan Blade
- 2-speed Selection



- Cross flow fan adopted for side and uniform airflow
- Thick air stream to provide high airflow momentum
- Fan blade made of resin with glass fibre and metal bush
- Permanently-lubricated ball bearing equipped
- Air deflection plate for airflow direction adjustment
- Soft touch switch panel with 2-speed selection
- Motor insulation Class B (4015UA: F)

## Dimension

Unit : mm

Model	3009UA	3012UA	3015UA
	4009UA	4012UA	4015UA
A	900	1,200	1,500
B	50	200	350

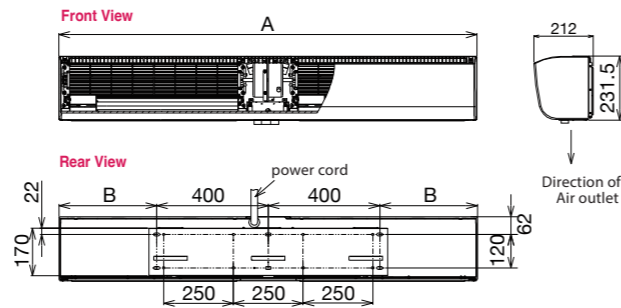

## Wiring Diagram

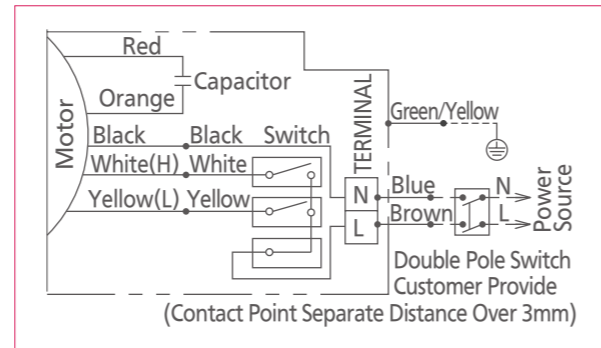

# Feature of Sirocco Type Air Curtain

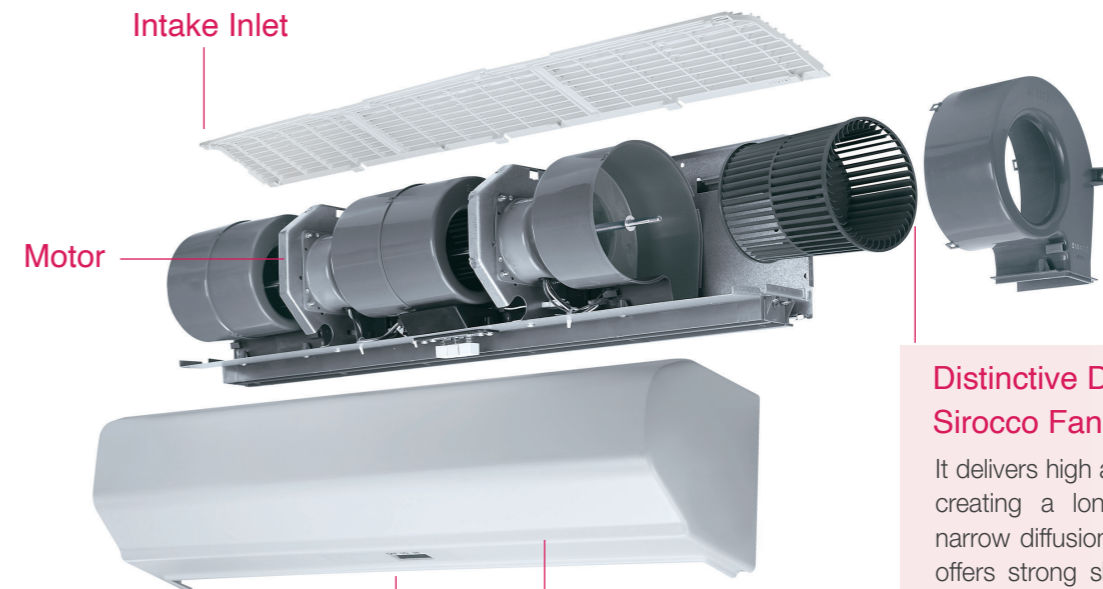

## Distinctive Design of Sirocco Fan

It delivers high air velocity, yet creating a long reach and narrow diffusion of airflow. It offers strong shut out ability while allowing people passing through comfortably.

## ABS Resin Casing

ABS is a material highly resistant to rust and with high bending flexibility, that enables a sleek, simple design fitting to modern interiors.

## Two-Speed Function



## Specification

Model	Voltage		Air Volume		Consumption [W]	Current [A]	Outlet Velocity [m/s]	Noise [dB(A)]	Weight [kg]
	[V]	[Hz]	[CMH]	[CFM]					
3009UA	220	50	Hi 1,100	647	76	0.35	10.5	48.5	12.5
		60	Lo 920	541	70	0.32	8.5	45.0	
	240	50	Hi 1,100	647	92	0.42	10.5	49.5	
		60	Lo 900	530	78	0.36	8.5	45.0	
4009UA	220	50	Hi 1,150	677	86	0.37	10.5	50.5	13.5
		60	Lo 960	565	80	0.35	9.0	47.5	
	240	50	Hi 1,340	789	110	0.50	12.0	54.5	
		60	Lo 1,190	700	94	0.43	10.0	51.0	
3012UA	220	50	Hi 1,340	789	141	0.64	12.0	55.5	15.0
		60	Lo 1,100	647	111	0.51	10.0	51.0	
	240	50	Hi 1,360	800	122	0.51	12.5	56.5	
		60	Lo 1,200	706	100	0.43	11.0	53.5	
4012UA	220	50	Hi 1,400	824	94	0.43	9.5	48.5	16.0
		60	Lo 1,270	747	85	0.40	8.0	45.0	
	240	50	Hi 1,400	824	109	0.51	9.5	48.5	
		60	Lo 1,250	736	94	0.46	8.0	45.0	
3015UA	220	50	Hi 1,500	883	107	0.46	10.0	50.5	18.5
		60	Lo 1,320	777	95	0.43	9.0	47.0	
	240	50	Hi 1,700	1,001	126	0.59	12.0	52.5	
		60	Lo 1,530	901	105	0.49	10.0	49.0	
4015UA	220	50	Hi 1,700	1,001	153	0.70	12.0	52.5	18.5
		60	Lo 1,450	853	118	0.55	10.0	49.0	
	240	50	Hi 1,800	1,059	139	0.60	12.5	54.5	
		60	Lo 1,580	930	110	0.49	11.0	51.0	
3015UA	220	50	Hi 2,000	1,177	131	0.59	10.5	51.5	18.5
		60	Lo 1,800	1,059	110	0.50	9.5	48.0	
	240	50	Hi 2,000	1,177	150	0.68	10.5	51.5	
		60	Lo 1,750	1,030	118	0.54	9.5	48.0	
4015UA	220	50	Hi 2,100	1,236	145	0.60	11.0	53.5	18.5
		60	Lo 1,850	1,089	115	0.50	10.0	50.5	
	240	50	Hi 2,450	1,442	177	0.81	13.0	56.0	
		60	Lo 2,000	1,177	147	0.68	10.0	52.0	
4015UA	220	50	Hi 2,300	1,354	220	1.01	13.0	56.0	18.5
		60	Lo 1,780	1,048	160	0.74	9.5	52.0	
	240	50	Hi 2,500	1,471	200	0.86	13.5	58.0	
		60	Lo 2,050	1,207	160	0.68	11.0	54.5	

Test Condition  
 Note : The parameters shown above are measured at ambient temperature of 20°C  
 - The values of noise level are measured at 1.5 m apart from the product at angle of 45° below the air outlet at which is the maximum value  
 - The velocity is measured in test laboratory. It may vary depends on different environment in actual usage

Length of unit	900mm (3 feet)	1200mm (4 feet)	900mm (3 feet)	1200mm (4 feet)	900mm (3 feet)	1200mm (4 feet)	900mm (3 feet)	1200mm (4 feet)
	08ESK	08ELK	10ESK	10ELK	12ESK	12ELK	14ESK	14ELK
Air velocity chart (m/s)								
Maximum value at HI speed 50Hz	3.5 - 4.5		4.5 - 5.5		6.0 - 7.0		7.5 - 8.5	
Efficient distance	2.5m (8 feet)		3.0m (10 feet)		3.5m (12 feet)		4.0m (14 feet)	



# Sirocco Type - 900 Series

Usage: Shopping Mall Retail Store

08ESK / 10ESK  
12ESK / 14ESK

Push Button Switch

ABS Resin Casing

2-speed Selection

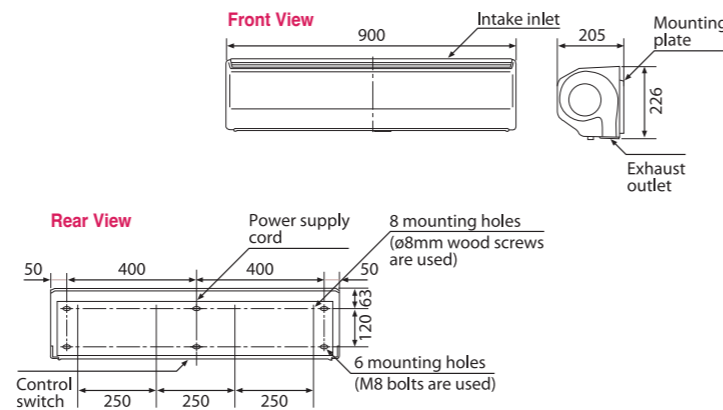

Wiring Diagram

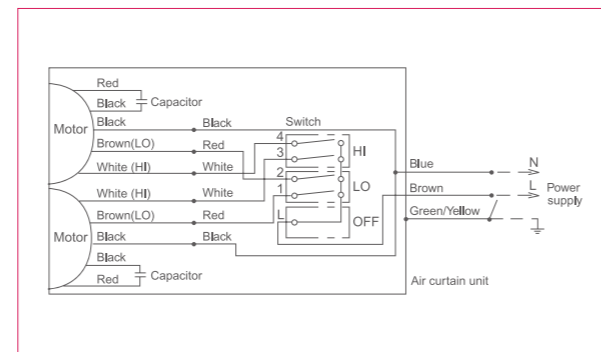

- Sirocco fan adopted for long reach and narrow diffusion of airflow
- ABS resin casing to provide better weather resistance
- Permanently-lubricated ball bearing equipped
- Air deflection plate for airflow direction adjustment
- Push button switch
- 2-speed selection
- Motor insulation Class E

## Specification

Model	Voltage			Air Volume		Consumption [W]	Current [A]	Outlet Velocity [m/s]	Noise [dB(A)]	Weight [kg]
	[V]	[Hz]		[CMH]	[CFM]					
08ESK	220	50	Hi	650	383	46	0.23	11.5	42	12.0
			Lo	580	341	42	0.21	10.3	39	
		60	Hi	690	406	57	0.28	12.1	43	
			Lo	560	330	49	0.25	9.9	38	
	240	50	Hi	680	400	51	0.24	11.9	43	
			Lo	620	365	47	0.23	10.9	41	
10ESK	220	50	Hi	750	441	72	0.40	13.0	46	12.0
			Lo	630	371	62	0.29	11.1	42	
		60	Hi	860	506	88	0.42	14.9	50	
			Lo	600	353	72	0.33	10.9	40	
	240	50	Hi	750	441	84	0.46	13.2	46	
			Lo	630	371	66	0.30	11.7	43	
12ESK	220	50	Hi	1,050	618	176	0.82	16.9	55	13.0
			Lo	960	565	155	0.69	15.8	50	
		60	Hi	990	583	202	0.94	16.1	54	
			Lo	940	553	170	0.75	15.3	49	
	240	50	Hi	1,120	659	200	0.86	17.9	57	
			Lo	1,040	612	169	0.75	16.8	54	
14ESK	220	50	Hi	1,340	789	257	1.14	21.9	62	13.0
			Lo	1,168	687	218	0.99	19.1	59	
		60	Hi	1,303	767	312	1.43	21.3	61	
			Lo	1,083	637	255	1.16	17.7	57	
	240	50	Hi	1,395	821	281	1.18	22.8	63	
			Lo	1,272	749	238	1.00	20.8	60	

Test Condition

Note : The parameters shown above are measured at ambient temperature of 20°C

- The values of noise level are measured at 1.5 m apart from the product at angle of 45° below the air outlet at which is the maximum value

- The velocity is measured in test laboratory. It may vary depends on different environment in actual usage

# Sirocco Type - 1200 Series

Usage: Shopping Mall Retail Store

08ELK / 10ELK  
12ELK / 14ELK

Push Button Switch

ABS Resin Casing

2-speed Selection

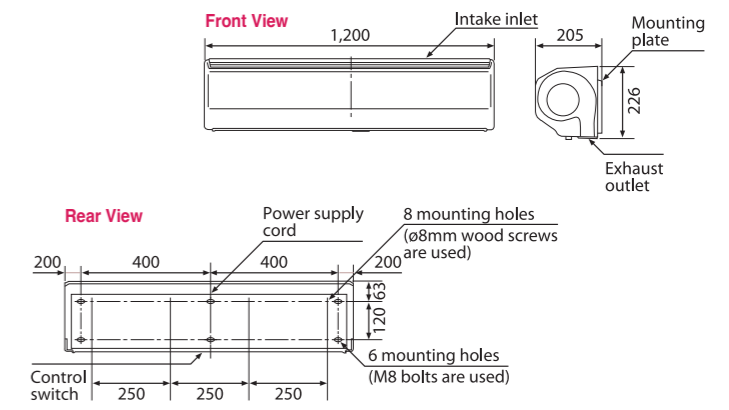

Wiring Diagram

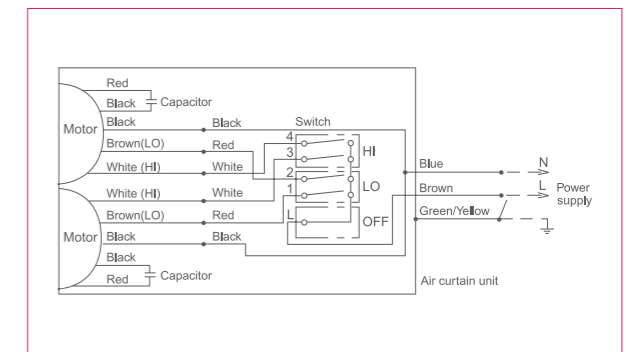

- Sirocco fan adopted for long reach and narrow diffusion of airflow
- ABS resin casing to provide better weather resistance
- Permanently-lubricated ball bearing equipped
- Air deflection plate for airflow direction adjustment
- Push button switch
- 2-speed selection
- Motor insulation Class E

## Specification

Model	Voltage			Air Volume		Consumption [W]	Current [A]	Outlet Velocity [m/s]	Noise [dB(A)]	Weight [kg]
	[V]	[Hz]		[CMH]	[CFM]					
08ELK	220	50	Hi	880	518	57	0.28	11.6	43	14.0
			Lo	800	471	53	0.27	10.6	41	
		60	Hi	940	553	74	0.36	12.4	45	
			Lo	790	465	62	0.32	10.5	40	
	240	50	Hi	920	541	65	0.29	12.1	44	
			Lo	850	500	59	0.28	11.2	42	
10ELK	220	50	Hi	1,000	589	96	0.54	13.1	46	14.0
			Lo	830	489	74	0.35	11.0	42	
		60	Hi	1,150	677	116	0.56	15.1	50	
			Lo	790	465	85	0.41	10.5	41	
	240	50	Hi	1,010	594	116	0.66	13.2	47	
			Lo	880	518	86	0.38	11.6	43	
12ELK	220	50	Hi	1,420	836	224	1.04	17.0	56	15.0
			Lo	1,320	777	200	0.90	15.8	51	
		60	Hi	1,340	789	258	1.21	16.2	55	
			Lo	1,290	759	220	1.04	15.4	50	
	240	50	Hi	1,510	889	252	1.10	17.9	58	
			Lo	1,410	830	218	0.98	16.7	56	
14ELK	220	50	Hi	1,867	1,099	333	1.52	22.5	63	15.0
			Lo	1,668	982	290	1.32	20.1	61	
		60	Hi	1,826	1,075	423	1.93	22.0	63	
			Lo	1,552	913	339	1.55	18.7	59	
	240	50	Hi	1,942	1,143	364	1.53	23.4	64	
			Lo	1,818	1,070	320	1.33	21.9	62	

Test Condition

Note : The parameters shown above are measured at ambient temperature of 20°C

- The values of noise level are measured at 1.5 m apart from the product at angle of 45° below the air outlet at which is the maximum value

- The velocity is measured in test laboratory. It may vary depends on different environment in actual usage

# Ceiling Fan / Electric Fan



High Breeze



Quiet



Safe



Scan for more information  
Ceiling Fan    Electric Fan

# Safety Feature of Ceiling Fan

In pursuit of high quality of life, ceiling fans are expected with multiple functions and more value-added features. Safety and reliability have become the major concerns when selecting a ceiling fan.

## Safety Shaft Cap

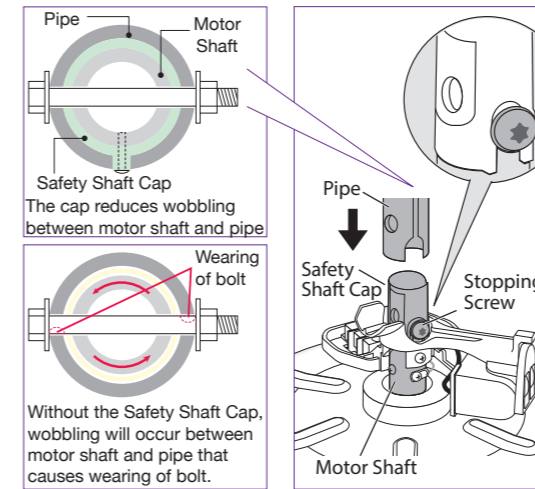

### Problem

Improper movement causes friction between bolt, motor shaft and pipe that increases wear and tear and cause fracture.

### Our solution

Safety Shaft Cap can reduce movement between bolt, motor shaft and pipe. This minimizes wearing of motor shaft and bolt, thus prevent falling of fan.

## Safety Wire

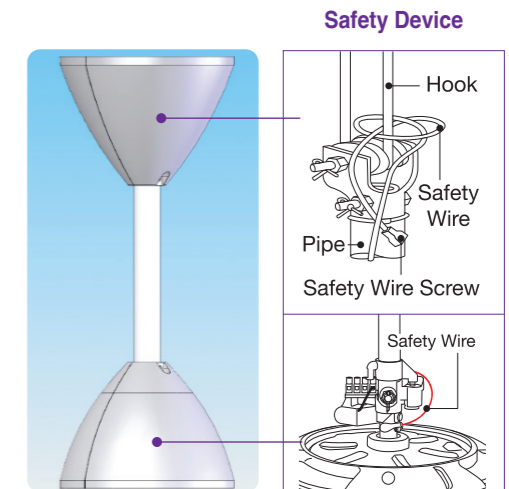

### Problem

Fan motor may fall from the pipe rod accidentally due to factors such as wearing of shaft, bolt etc.

### Our solution

Safety wire helps to secure fan motor with ceiling hook. This prevents falling of motor in case it detaches from the pipe rod.

## Safety Blade Plate / Hanger

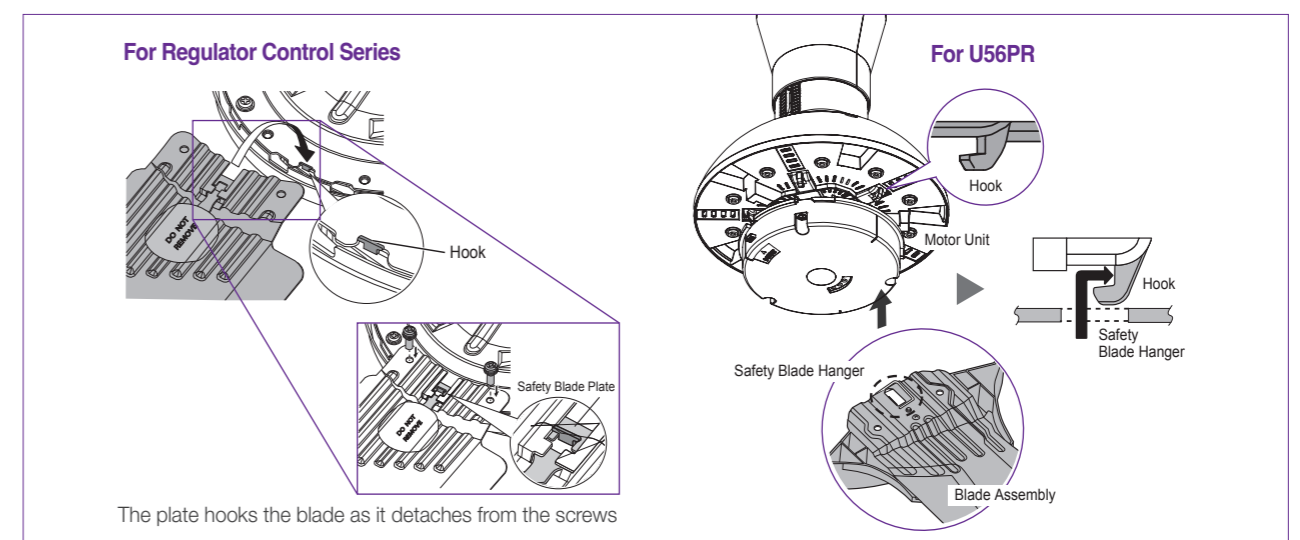

### Problem

Blade may break and fall off from fan motor in case fatigue failure of material occurs.

### Our solution

An exclusively designed fall prevention plate / hanger is equipped to hold blade to the motor in case of breakage. This mechanism secures against falling of blade.

# Remote Control Series

Usage: Living Room Bedroom Restaurant Lobby

## U56PR

- Remote Control
- Fall Prevention Measures
- Metal Blades



- 3-speed selection
- Off Timer with LED indicator (1, 3, 6 hours)
- Sleep mode
- Thermal fuse to prevent overheating
- Current fuse to secure against power surge
- Safety wire provided
- Safety shaft cap to prevent fan falling
- Permanently lubricated ball bearing equipped
- Motor insulation Class E
- Colour: White body with golden ring

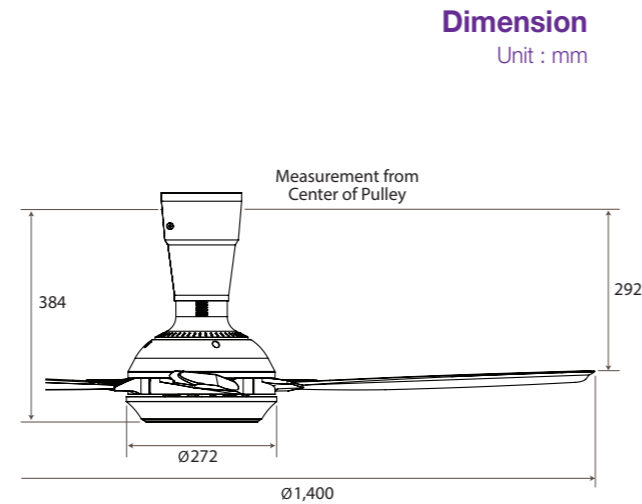

Dimension  
Unit : mm

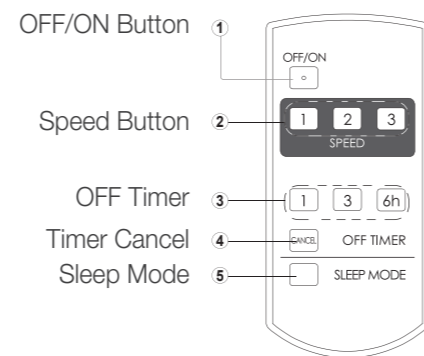

### Wiring Diagram

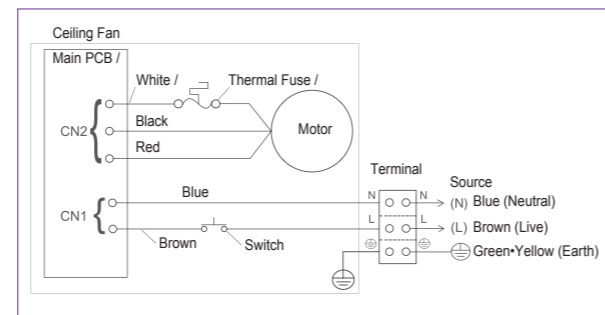

### Specification

Model	Voltage [V]	Frequency [Hz]	*	Consumption [W]	RPM	Air Velocity		Air Volume		Weight [kg]
						[m/min]	[ft/min]	[m³/min]	[ft³/min]	
U56PR	220	50	Hi	62	175	137	449	181	6,392	6.7
			Lo	20	87	-	-	-	-	
		Hi	74	182	146	479	194	6,851		
	230	50	Lo	21	89	-	-	-	-	
			Hi	66	182	146	479	194	6,851	
		Lo	19	89	-	-	-	-		
240	50	Hi	73	188	153	502	204	7,204		
		Lo	20	94	-	-	-	-		

\*Hi - Notch 3 / Lo - Notch 1

# Regulator Control Series

Usage: Living Room Bedroom Restaurant Lobby

## T48XC / T56XC

- Slim Panel Regulator
- Fall Prevention Measures
- Metal Blades



- 5-speed selection
- Thermal fuse to prevent overheating
- Safety wire provided
- Safety shaft cap to prevent fan falling
- Permanently lubricated ball bearing equipped
- Motor insulation Class E
- Colour option: Gray body with silver ring  
White body with golden ring

Dimension Unit : mm					
Model	9 inch	12 inch	16 inch	18 inch	22 inch
Pipe Length	229	305	406	457	559
F	437	513	614	665	764

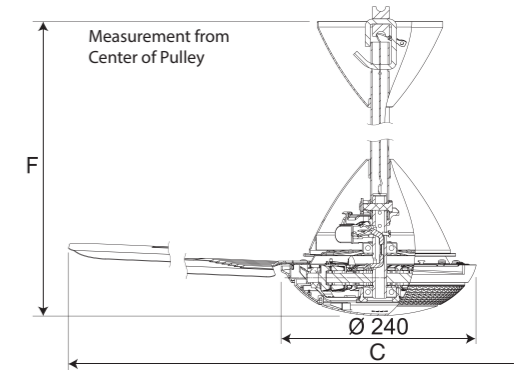

Model :	C
T48XC	Ø1,200
T48XGMN	Ø1,200
T56XC	Ø1,400
T56XGMN	Ø1,400

### Wiring Diagram

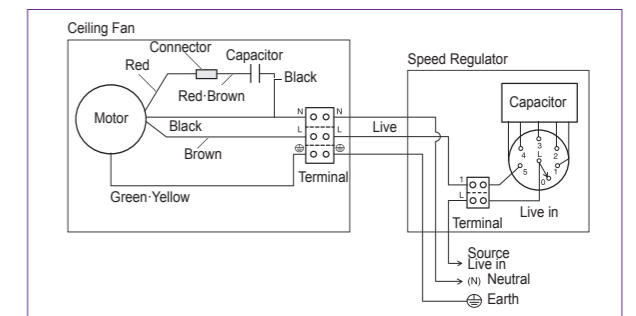

### Specification

Model	Voltage [V]	Frequency [Hz]	*	Consumption [W]	RPM	Air Velocity		Air Volume		Weight [kg]
						[m/min]	[ft/min]	[m³/min]	[ft³/min]	
T48XC	220	50	Hi	45	285	160	525	155	5,474	5.3
			Lo	15	137	-	-	-	-	
		Hi	55	311	175	574	170	6,003		
	230	50	Lo	15	129	-	-	-	-	
			Hi	49	296	165	541	170	6,003	
		Lo	16	146	-	-	-	-		
T56XC	220	50	Hi	51	303	170	558	165	5,827	5.6
			Lo	18	154	-	-	-	-	
		Hi	70	268	165	541	220	7,769		
	230	50	Lo	14	103	-	-	-	-	
			Hi	76	268	170	558	225	7,946	
		Lo	17	106	-	-	-	-		
240	50	Hi	75	275	170	558	225	7,946		
		Lo	15	109	-	-	-	-		
	Hi	76	273	165	541	220	7,769			
Lo	17	115	-	-	-	-				

\*Hi - Notch 5 / Lo - Notch 1

# Regulator Control Series

Usage: Living Room Bedroom Restaurant Lobby

## T48XG / T56XG

- Compact Regulator
- Fall Prevention Measures
- Metal Blades



- 5-speed selection
- Thermal fuse to prevent overheating
- Safety wire provided
- Safety shaft cap to prevent fan falling
- Permanently lubricated ball bearing equipped
- Glossy diamond-pattern fan ring
- Motor insulation Class E
- Colour option: White body with golden ring  
Gray body with silver ring

**Dimension**  
Unit : mm

Model	9 inch	12 inch	16 inch	18 inch	22 inch
Pipe Length	229	305	406	457	559
F	437	513	614	665	764

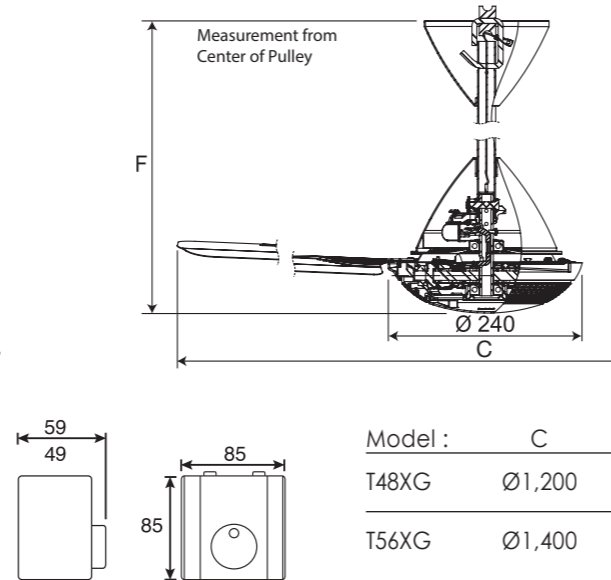

### Wiring Diagram

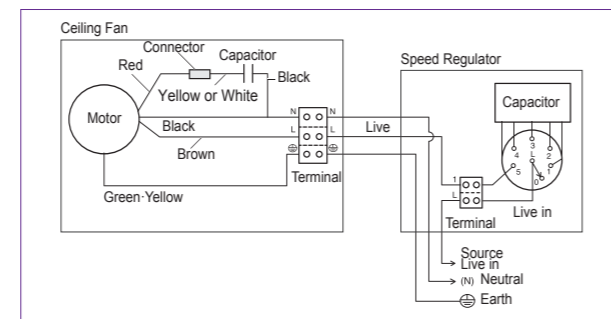

### Specification

Model	Voltage [V]	Frequency [Hz]	*	Consumption [W]	RPM	Air Velocity		Air Volume		Weight [kg]
						[m/min]	[ft/min]	[m³/min]	[ft³/min]	
T48XG	220	50	Hi	45	285	160	525	155	5,474	5.3
			Lo	15	137	-	-	-	-	
		60	Hi	55	311	175	574	170	6,003	
			Lo	15	129	-	-	-	-	
	230	50	Hi	49	296	165	541	170	6,003	
			Lo	16	146	-	-	-	-	
		240	Hi	51	303	170	558	165	5,827	
			Lo	18	154	-	-	-	-	
T56XG	220	50	Hi	70	268	165	541	220	7,769	5.6
			Lo	14	103	-	-	-	-	
		60	Hi	76	268	170	558	225	7,946	
			Lo	17	106	-	-	-	-	
	230	50	Hi	75	275	170	558	225	7,946	
			Lo	15	109	-	-	-	-	
		240	Hi	76	273	165	541	220	7,769	
			Lo	17	115	-	-	-	-	

\*Hi - Notch 5 / Lo - Notch 1

# Regulator Control Series

Usage: Living Room Bedroom Restaurant Lobby

## X48XC / X56XC

- Slim Panel Regulator
- Fall Prevention Measures
- Metal Blades



- 5-speed selection
- Thermal fuse to prevent overheating
- Safety wire provided
- Safety shaft cap to prevent fan falling
- Permanently lubricated ball bearing equipped
- Motor insulation Class E
- Colour: White body with silver ring

**Dimension**  
Unit : mm

Model	9 inch	12 inch	16 inch	18 inch	22 inch
Pipe Length	229	305	406	457	559
F	437	513	614	665	764

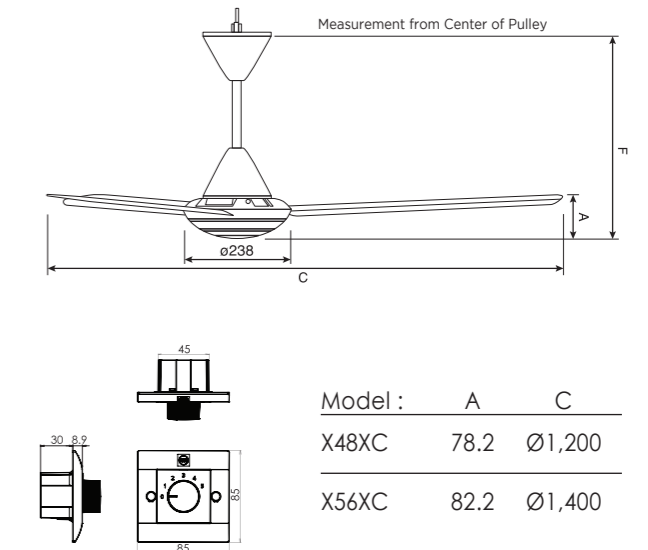

### Wiring Diagram

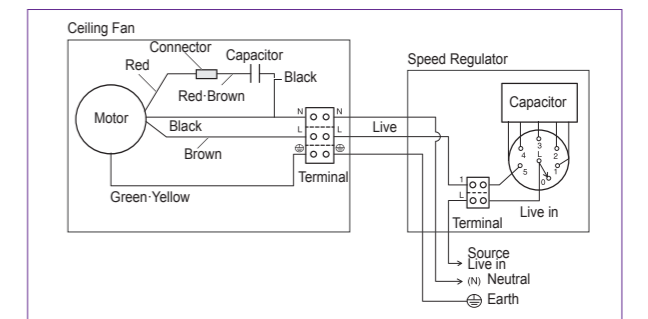

### Specification

Model	Voltage [V]	Frequency [Hz]	*	Consumption [W]	RPM	Air Velocity		Air Volume		Weight [kg]
						[m/min]	[ft/min]	[m³/min]	[ft³/min]	
X48XC	220	50	Hi	45	285	160	525	155	5,474	5.3
			Lo	15	137	-	-	-	-	
		60	Hi	55	311	175	574	170	6,003	
			Lo	15	129	-	-	-	-	
	230	50	Hi	49	296	165	541	170	6,003	
			Lo	16	146	-	-	-	-	
		240	Hi	51	303	170	558	165	5,827	
			Lo	18	154	-	-	-	-	
X56XC	220	50	Hi	70	268	165	541	220	7,769	5.6
			Lo	14	103	-	-	-	-	
		60	Hi	76	268	170	558	225	7,946	
			Lo	17	106	-	-	-	-	
	230	50	Hi	75	275	170	558	225	7,946	
			Lo	15	109	-	-	-	-	
		240	Hi	76	273	165	541	220	7,769	
			Lo	17	115	-	-	-	-	

\*Hi - Notch 5 / Lo - Notch 1

# Regulator Control Series

Usage: Living Room Bedroom Restaurant Lobby

## X48XG / X56XG

- Compact Regulator
- Fall Prevention Measures
- Metal Blades

Dimension  
Unit : mm

Model	9 inch	12 inch	16 inch	18 inch	22 inch
Pipe Length	229	305	406	457	559
F	437	513	614	665	764

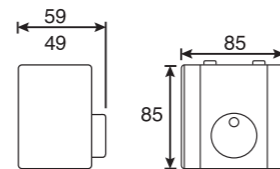
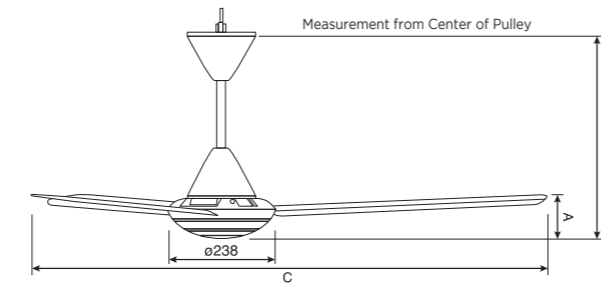

Model :	C
X48XG	Ø1,200
X56XG	Ø1,400

- 5-speed selection
- Thermal fuse to prevent overheating
- Safety wire provided
- Safety shaft cap to prevent fan falling
- Permanently lubricated ball bearing equipped
- Motor insulation Class E
- Colour: White body with silver ring

### Wiring Diagram

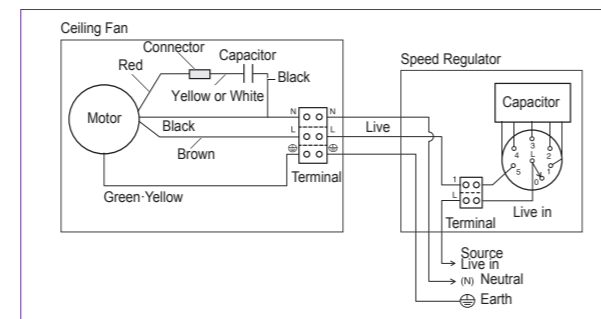

### Specification

Model	Voltage [V]	Frequency [Hz]	*	Consumption [W]	RPM	Air Velocity		Air Volume		Weight [kg]
						[m/min]	[ft/min]	[m³/min]	[ft³/min]	
X48XG	220	50	Hi	45	285	160	525	155	5,474	5.3
			Lo	15	137	-	-	-	-	
		60	Hi	55	311	175	574	170	6,003	
			Lo	15	129	-	-	-	-	
	230	50	Hi	49	296	165	541	170	6,003	
			Lo	16	146	-	-	-	-	
240	50	Hi	51	303	170	558	165	5,827		
		Lo	18	154	-	-	-	-		
X56XG	220	50	Hi	70	268	165	541	220	7,769	5.6
			Lo	14	103	-	-	-	-	
		60	Hi	76	268	170	558	225	7,946	
			Lo	17	106	-	-	-	-	
	230	50	Hi	75	275	170	558	225	7,946	
			Lo	15	109	-	-	-	-	
240	50	Hi	76	273	165	541	220	7,769		
		Lo	17	115	-	-	-	-		

\*Hi - Notch 5 / Lo - Notch 1

# Cycle Fan

Usage: Living Room Bedroom Restaurant School

## M40R

- 360° Oscillation
- Regulator
- Metal Blades

### Adjustment of Circulating Angle

The oscillation angle can be adjusted to 15, 30, 50 degrees.

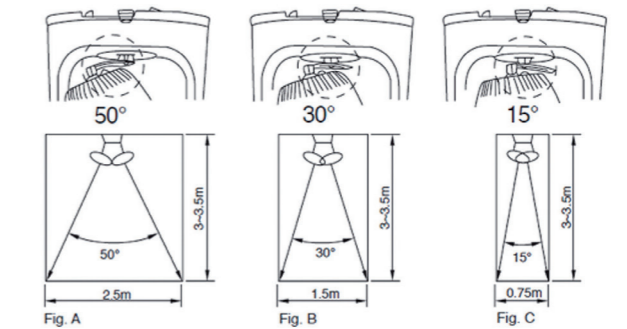

- 5-speed selection
- Oscillation over 360°
- Speed and ON/OFF controlled by regulator
- Easy adjustment for circulating angle (15°, 30°, 50°)
- Thermal fuse to prevent overheating
- Safety wire provided
- Permanently lubricated ball bearing equipped
- Painted metal blades
- Colour option: Blue
- Gray

### Wiring Diagram

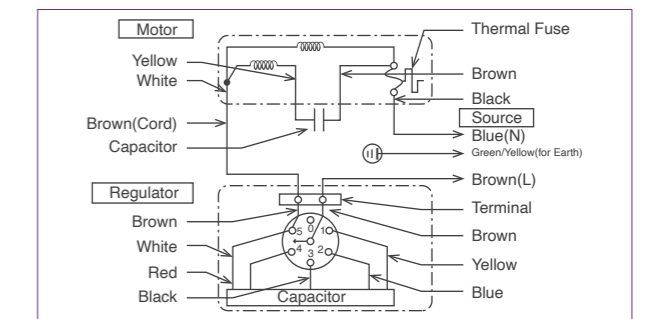

### Specification

Model	Voltage [V]	Frequency [Hz]	*	Consumption [W]	RPM	Air Velocity		Air Volume		Weight [kg]
						[m/min]	[ft/min]	[m³/min]	[ft³/min]	
M40R	220	50	Hi	46.8 - 57.2	1,080 - 1,320	256	840	79	2,790	4.3
			Lo	22.5 - 27.5	690 - 850	-	-	-	-	
		60	Hi	57.7 - 70.5	1,160 - 1,410	277	909	86	3,037	
			Lo	26.6 - 32.5	710 - 860	-	-	-	-	

\*Hi - Notch 5 / Lo - Notch 1

# Wall Fan - Cord-Operated Series

Usage: Living Room Bedroom Restaurant School

## M30C / M40C

Pull Switch

Easy Angle Adjustment

3-speed Selection

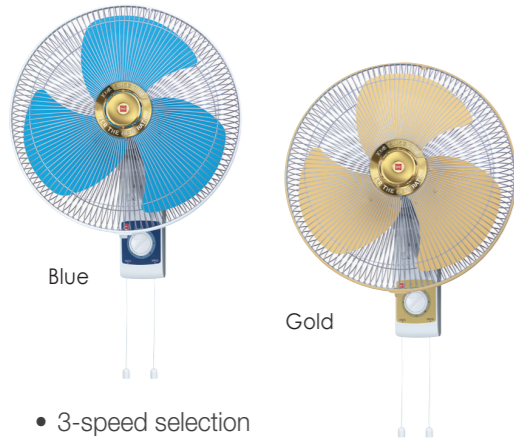

- 3-speed selection
- Speed and ON/OFF controlled by pull switch
- Speed and Oscillation change by pull cord
- Easy adjustment for tilt angle and oscillation angle
- Thermal fuse to prevent overheating
- Safety shaft cap to prevent fan falling
- Permanently lubricated ball bearing equipped
- Colour option: Blue (M30C and M40C)  
Gold (M40C only)

### Adjustment of Tilt Angle and Oscillation Angle

#### “One-touch” adjustment of tilt

The airflow can be adjusted upward or downward by simply moving the guard up or down as shown in the figure. Adjust the angle of the fan only after first confirming that it has stopped rotating.

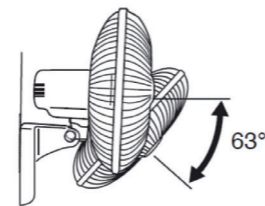

#### Double oscillation

To change the direction of the air flow, simply push the fan guard to the desired position.

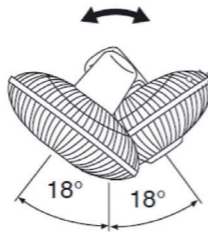

### Installation

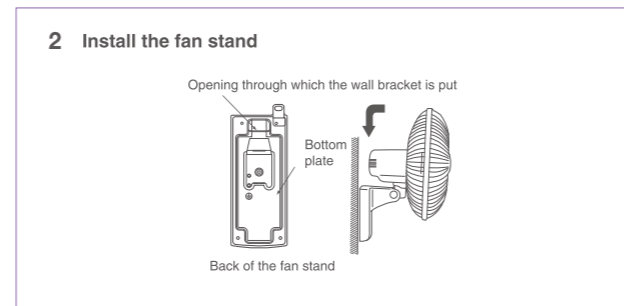
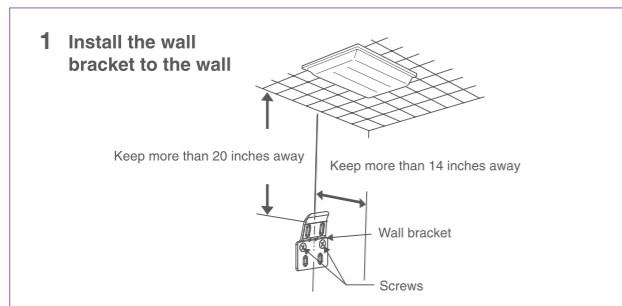

### Specification

Model	Voltage [V]	Frequency [Hz]	*	Consumption [W]	RPM	Air Velocity		Air Volume		Weight [kg]
						[m/min]	[ft/min]	[m³/min]	[ft³/min]	
M30C	220	50	Hi	34.0 - 41.6	1,124 - 1,374	215	705	45	1,589	3.4
			Lo	26.3 - 32.1	779 - 952	-	-	-	-	
		60	Hi	39.5 - 48.3	1,244 - 1,520	237	778	50	1,766	
			Lo	27.3 - 33.3	714 - 872	-	-	-	-	
M40C	220	50	Hi	42.5 - 51.9	1,097 - 1,341	226	741	63	2,225	4.4
			Lo	33.5 - 40.9	744 - 910	-	-	-	-	
		60	Hi	52.8 - 64.6	1,166 - 1,425	241	791	67	2,366	
			Lo	34.7 - 42.5	676 - 826	-	-	-	-	

\*Hi - Notch 3 / Lo - Notch 1

# Wall Fan - Remote Control Series

Usage: Living Room Bedroom Restaurant School

## M40M

Remote Control

Easy Angle Adjustment

3-speed Selection



- 3-speed selection
- Remote control for speed, oscillation and off timer
- Soft touch switch panel with LED indicator
- Off timer (1, 3, 6 hours)
- Easy adjustment for tilt angle and oscillation angle
- Thermal fuse to prevent overheating
- Safety shaft cap to prevent fan falling
- Permanently lubricated ball bearing equipped
- Transparent plastic blade
- Colour option: Gray or Black

### Adjustment of Tilt Angle and Oscillation Angle

#### “One-touch” adjustment of tilt

The airflow can be adjusted upward or downward by simply moving the guard up or down as shown in the figure. Adjust the angle of the fan only after first confirming that it has stopped rotating.

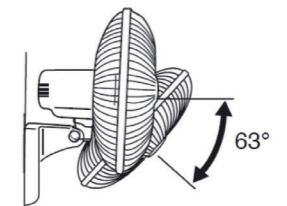

#### Double oscillation

To change the direction of the air flow, simply push the fan guard to the desired position.

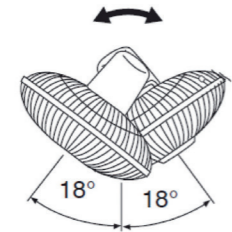

### Installation

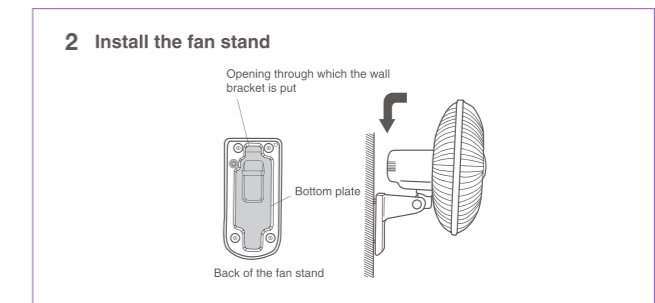
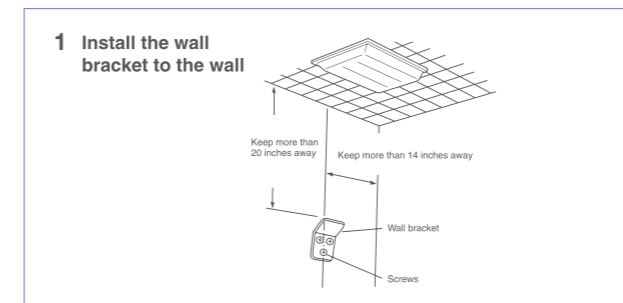

### Specification

Model	Voltage [V]	Frequency [Hz]	*	Consumption [W]	RPM	Air Velocity		Air Volume		Weight [kg]
						[m/min]	[ft/min]	[m³/min]	[ft³/min]	
M40M	220	50	Hi	46.8 - 57.2	1,055 - 1,289	228	748	63	2,225	4.4
			Lo	37.9 - 46.3	688 - 840	-	-	-	-	
		60	Hi	56.1 - 68.5	1,094 - 1,337	237	778	65	2,295	
			Lo	37.9 - 46.3	625 - 763	-	-	-	-	

\*Hi - Notch 3 / Lo - Notch 1

# Wall Fan - Big Wall Fan

Usage: Restaurant School Wet Market Shopping Street

## YU50X

Guide Vane Design

Aluminium Blades

3-speed Selection



- Guide Vane design generates strong and focus air flow up to 10 m distance
- Aluminum blades for stronger air flow and durability
- Added angle adjust bolt for extra stability on the fan's knee joint
- Full automatic oscillation
- 3-speed ON/OFF pull switch
- New and modern Front Guard Design

### New Guide Vane

Guide Vane shape is matched to intake flow, minimizing pressure loss.

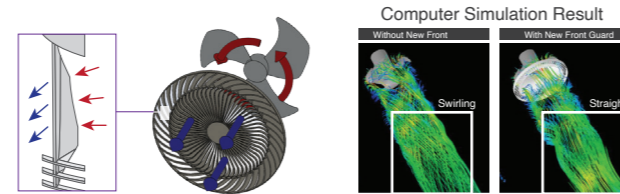

Guide Vane  
Change swirling flow to straight restrain flow spreading

### New Metal Blade Design

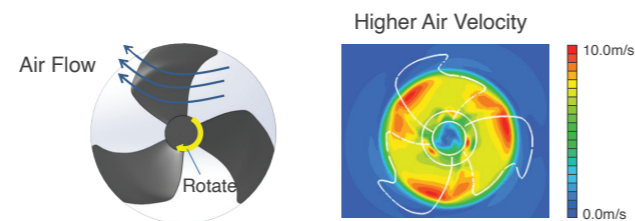

New Guide Vane and metal blade design bring larger air volume and higher air velocity to reach further distance.

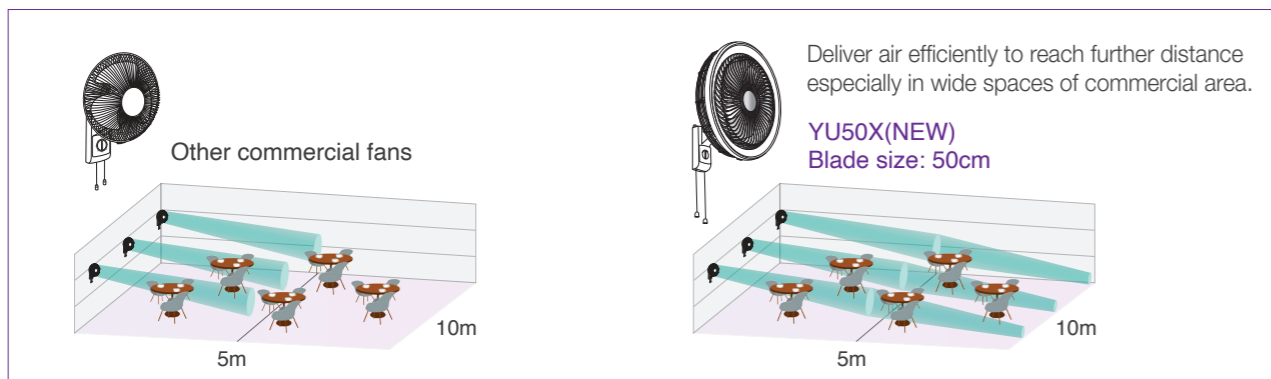

### Specification

Model	Voltage [V]	Frequency [Hz]	*	Consumption [W]	RPM	Air Velocity		Air Volume		Weight [kg]
						[m/min]	[ft/min]	[m³/min]	[ft³/min]	
YU50X	220	50	Hi	63	1,230	280	919	100	3,531	4.4
			Lo	53	850	-	-	-	-	
			Hi	67	1,260	290	951	105	3,708	
			Lo	56	880	-	-	-	-	
	230	50	Hi	70	1,280	300	984	110	3,885	
			Lo	60	940	-	-	-	-	
	240	50	Hi	60	1,200	290	951	115	4,061	
			Lo	51	920	-	-	-	-	
	220	60	Hi	76	1,220	295	968	120	4,238	
			Lo	53	800	-	-	-	-	

\*Hi - Notch 3 / Lo - Notch 1

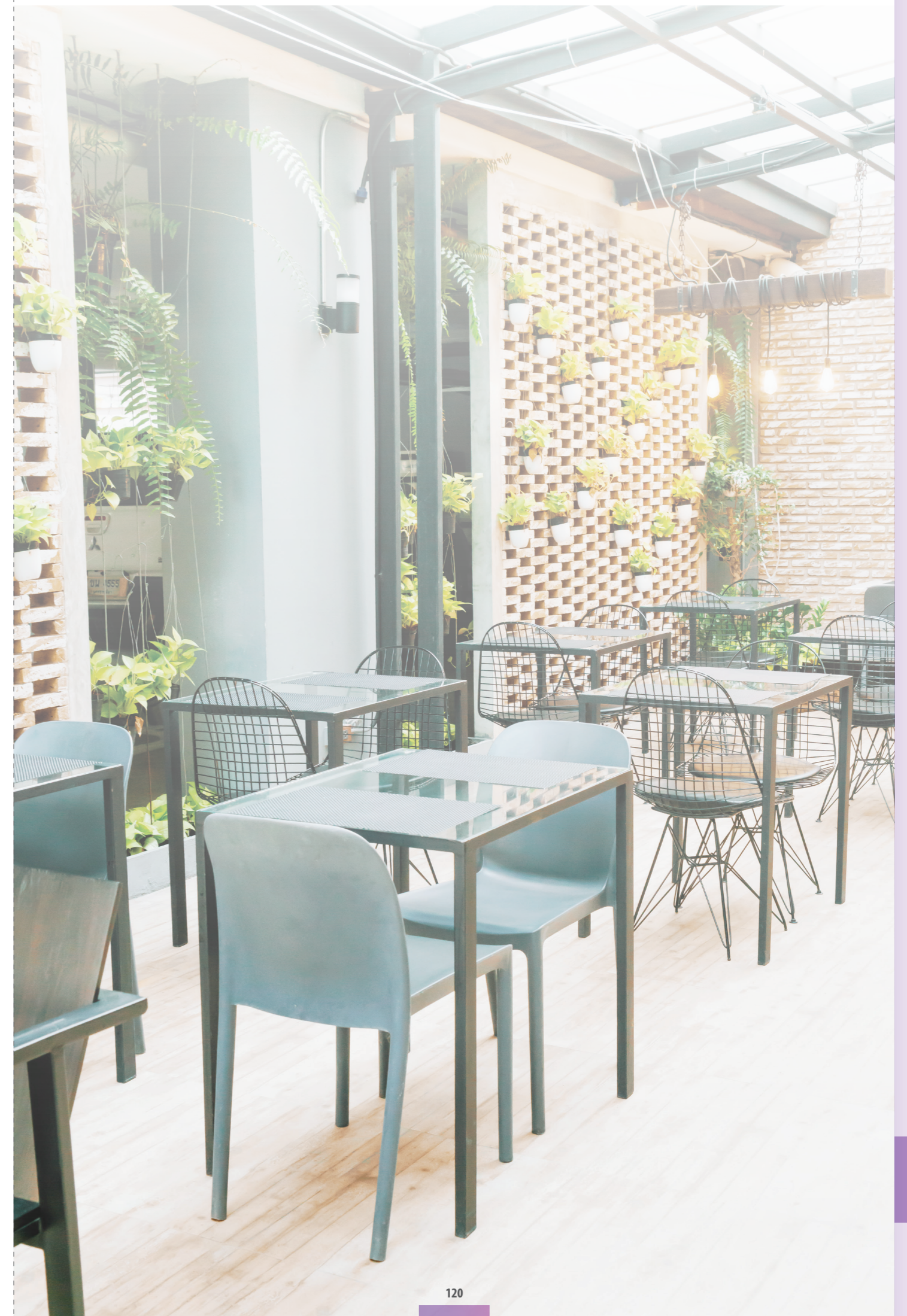

# Ventilation Product Specification Summary

## ■ Ceiling Mount Type Ventilation Fan (AMCA Certified)

Series	Model	Voltage [V]	Frequency [Hz]	Speed	CFM / SONE AT STATIC Pressure (ps-inches of H <sub>2</sub> O)										RPM	Watts*		Watts**
					Inches of H <sub>2</sub> O	0	0.1	0.125	0.25	0.375	0.5	0.625	0.75	0.875		For AMCA	For ICE	
Super Quiet Series	17CUH	220	60	-	CFM	44	32	29	-	-	-	-	-	-	664	10	10	
					Sones	0.3	0.5	0.6	-	-	-	-	-	-				
	240	50	-	CFM	51	43	40	-	-	-	-	-	-	728	10	9.5		
				Sones	0.3	0.4	0.5	-	-	-	-	-	-					
	24CUH	220	60	-	CFM	83	73	68	46	-	-	-	-	-	585	13	13.5	
					Sones	0.4	0.5	0.6	1.3	-	-	-	-	-				
	240	50	-	CFM	89	77	75	51	-	-	-	-	-	614	13	12		
				Sones	0.5	0.7	0.7	1.4	-	-	-	-	-					
	24CDH	240	50	-	CFM	106	93	89	65	-	-	-	-	-	782	17	16.5	
					Sones	0.9	0.9	0.9	1.6	-	-	-	-	-				
	24CHH	220	60	-	CFM	109	99	96	75	48	-	-	-	-	791	22	20.5	
					Sones	1.0	0.9	1.0	1.3	2.2	-	-	-	-				
	240	50	-	CFM	117	109	96	73	33	-	-	-	-	861	21	19.5		
				Sones	1.2	1.2	1.2	1.3	1.8	-	-	-	-					
	24CXH	220	50	-	CFM	tbc	tbc	tbc	tbc	tbc	-	-	-	-				
					Sones													
CFM																		
Sones																		
27CHH	220	60	Hi	CFM	182	162	156	118	78	37	-	-	-	570	33	33		
				Sones	1.1	1.2	1.3	1.7	2.2	2.5	-	-	-					
	240	50	Hi	CFM	198	179	172	126	78	18	-	-	-	609	37	34		
				Sones	1.4	1.5	1.6	1.8	2.3	2.5	-	-	-					
32CDH	220	60	Hi	CFM	226	202	196	163	127	91	53	-	-	580	48	48		
				Sones	1.2	1.3	1.4	1.7	2.2	2.7	3.3	-	-					
240	50	Hi	CFM	257	236	230	192	147	99	53	-	-	675	56	50			
			Sones	1.6	1.7	1.8	1.9	2.5	3.0	3.6	-	-						

Performance certified is for installation type B: Free inlet, Ducted outlet. Performance ratings include the effects of an inlet grille and backdraft shutter. Speed (RPM) shown is nominal. Performance is based on actual speed of test. The sound ratings shown are loudness values in fan sones at 5 ft. (1.5m) in a hemispherical free field calculated per AMCA International Standard 301. Values shown are for installation type B: Free inlet hemispherical sone levels.

\* the Watts rating is for AMCA test method and it is at the static pressure of 0 inch of H<sub>2</sub>O.

\*\* the Watts rating is only for IEC test method and the AMCA Certified Rating Seal does not apply to IEC test method watts.

## ■ Ceiling Mount Type Ventilation Fan (AMCA Certified)

Series	Model	Voltage [V]	Frequency [Hz]	Speed	CFM / SONE AT STATIC Pressure (ps-inches of H <sub>2</sub> O)										RPM	Watts*		Watts**
					Inches of H <sub>2</sub> O	0	0.1	0.125	0.25	0.375	0.5	0.625	0.75	0.875		For AMCA	For ICE	
DC Motor Series	24JRB	220	60	Hi	CFM	88	88	88	88	63	34	5	-	-	853	10	8	
					Sones	0.7	1.0	1.0	1.3	1.7	1.8	3.1	-	-				
	240	50	Hi	CFM	88	88	88	88	63	34	5	-	-					
				Sones	0.7	1.0	1.0	1.3	1.7	1.8	3.1	-	-					
24JAB	220	60	Hi	CFM	88	88	88	88	63	34	5	-	-	839	10	8		
				Sones	0.6	0.9	1.0	1.4	1.6	1.9	3.2	-	-					
	240	50	Hi	CFM	88	88	88	88	63	34	5	-	-					
				Sones	0.6	0.9	1.0	1.4	1.6	1.9	3.2	-	-					
Metal Series	24CMUA	220	60	-	CFM	55	40	37	20	-	-	-	-	495	13	12		
					Sones	0.3	0.7	0.8	1.6	-	-	-	-					
	240	50	-	CFM	55	44	41	24	-	-	-	-	562	14	13			
				Sones	0.3	0.8	1.0	1.4	-	-	-	-						
	24CMHA	220	60	-	CFM	94	85	83	72	54	-	-	-	681	25	23		
					Sones	1.0	1.4	1.5	1.9	2.3	-	-	-				-	
	240	50	-	CFM	108	98	95	77	44	-	-	-	-	753	27	25		
				Sones	1.4	1.8	1.9	2.1	2.2	-	-	-	-					
27CMHA	220	60	-	CFM	208	184	178	144	108	79	-	-	-	615	46	43		
				Sones	1.6	1.7	1.7	2.3	3.2	3.5	-	-	-					
240	50	-	CFM	219	194	188	150	110	70	-	-	-	669	46	43			
			Sones	1.9	1.9	2.0	2.4	3.4	3.1	-	-	-						
Standard Series	38CDG	220	60	Hi	CFM	344	323	317	290	261	230	197	163	126	626	98	98	
					Sones	3.1	3.2	3.2	3.3	3.6	4.1	4.5	5.7	5.7				
38CDG 05 38CDG	240	50	Hi	CFM	387	367	362	336	305	259	212	165	108	737	118	107		
				Sones	4.0	4.1	4.2	4.3	4.4	4.7	5.3	5.7	6.2					

Performance certified is for installation type B: Free inlet, Ducted outlet. Performance ratings include the effects of an inlet grille and backdraft shutter. Speed (RPM) shown is nominal. Performance is based on actual speed of test. The sound ratings shown are loudness values in fan sones at 5 ft. (1.5m) in a hemispherical free field calculated per AMCA International Standard 301. Values shown are for installation type B: Free inlet hemispherical sone levels.

\* the Watts rating is only for AMCA test method and it is at the static pressure of 0 inch of H<sub>2</sub>O.

\*\* the Watts rating is only for IEC test method and the AMCA Certified Ratings Seal does not apply to IEC test method watts.

# Ventilation Product Specification Summary

## Cabinet Fan (In-line Fan) (AMCA Certified)

Low Noise Type Cabinet Fan Model Comparison																			
Model	Voltage [V]	Frequency [Hz]	Speed	CFM / SONE AT STATIC Pressure (ps-inches of H <sub>2</sub> O)											RPM	Watts*		Watts**	
				Inches of H <sub>2</sub> O	0	0.1	0.125	0.25	0.375	0.5	0.75	1	1.25	1.5		For AMCA	For ICE		
12NSB	220	60	Hi	CFM	114	105	102	87	65	-	-	-	-	-	-	1,460	26	23	
				Sones	1.5	1.4	1.4	1.3	1.4	-	-	-	-	-					
15NSB	220	60	Hi	CFM	200	183	177	149	118	83	-	-	-	-	1,520	45	42		
				Sones	2.7	2.5	2.4	2.3	2.2	2.0	-	-	-	-					
18NSB	220	60	Hi	CFM	274	261	258	241	222	196	137	-	-	-	1,470	80	73		
				Sones	3.3	3.1	3.0	2.9	2.7	2.6	2.7	-	-	-					
18NFB	220	60	Hi	CFM	417	399	395	373	347	318	237	-	-	-	1,420	128	119		
				Sones	4.0	3.9	3.9	3.9	3.6	3.5	3.4	-	-	-					
20NSB	220	60	Hi	CFM	469	459	456	444	433	413	354	275	-	-	1,380	170	159		
				Sones	4.0	4.0	3.9	3.8	3.9	4.0	4.1	4.2	-	-					
23NLB	220	60	Hi	CFM	655	642	640	625	611	597	555	505	440	-	1,400	350	310		
				Sones	6.0	6.0	5.9	5.9	5.7	5.7	5.8	5.8	5.8	-					
25NSB	220	60	Hi	CFM	940	924	919	899	877	857	790	710	610	5.2	1,380	460	425		
				Sones	7.1	7.1	7.1	7.0	6.8	6.8	6.7	6.7	6.7	6.9					
25NFB	220	60	Hi	CFM	1,016	1,000	995	975	954	933	875	803	710	590	1,420	680	520		
				Sones	8.2	8.2	8.2	8.2	7.9	7.9	7.8	7.6	7.5	7.5					
25NSB	240	50	Hi	CFM	963	938	935	906	868	822	719	567	395	-	1,305	481	370		
				Sones	10.1	9.8	9.7	9.3	9.2	8.8	8.0	7.5	8.2	-					
25NFB	240	50	Hi	CFM	1,057	1,048	1,040	1,010	972	922	811	660	473	-	1,330	537	430		
				Sones	12.1	11.9	11.5	11.1	10.6	9.8	8.7	8.7	10.3	-					

Performance certified is for installation type D: Ducted inlet, Ducted outlet. Performance ratings do not include the effects of appurtenances (accessories). Speed (RPM) shown is nominal. Performance is based on actual speed of test. The sound ratings shown are loudness values in fan sonas at 5 ft. (1.5m) in a hemispherical free field calculated per AMCA International Standard 301. Values shown are for installation type D: ducted inlet hemispherical sone levels. Ratings do not include the effect of duct end correction.  
 \* the Watts rating is for AMCA test method and it is at the static pressure of 0 inch of H<sub>2</sub>O.  
 \*\* the Watts rating is only for IEC test method and the AMCA Certified Rating Seal does not apply to IEC test method watts.

Low Noise Type Cabinet Fan (Three Phase Series) Model Comparison (Non-AMCA Certified)											
Model	Phase	Voltage [V]	Frequency [Hz]	Consumption [W]	RPM	Air Volume		Noise [dB(A)]	Weight [kg]	Duct Size [mm]	Impeller Diameter [mm]
						[CMH]	[CFM]				
25SWC	3	380	50	940	1,375	4,000	2,354	43	60	250 x 250	250
			60	1,450	1,530	4,500	2,648	45			
25SMC	3	380	50	1,180	1,345	5,200	3,060	45	60	250 x 700	250
			60	1,750	1,470	5,500	3,237	46			
28NXC	3	380	50	600	1,295	2,600	1,560	44	28	Ø250	280
			60	840	1,380	2,650	1,560	45			

Note:  
 The value in specification tables are representative characteristic value at 380V 50/60Hz.  
 RPM data is for reference only. Values may vary subject to different conditions.  
 The above Low Noise Type Cabinet Fan (Three Phase Series) Model are not licensed to bear the AMCA Certified Rating Seal.

## Industrial Type Ventilation Fan (AMCA Certified)

Model	Voltage [V]	Frequency [Hz]	CFM / SONE AT STATIC Pressure (ps-inches of H <sub>2</sub> O)										RPM	Watts*		Watts**	
			Inches of H <sub>2</sub> O	0	0.05	0.075	0.1	0.125	0.25	0.375	0.5	0.375		FOR AMCA	FOR IEC		
25GSE	220	60	CFM	788	742	715	686	647	-	-	-	-	1,570	61	57		
			Sones	4.9	4.7	4.5	4.5	4.6	-	-	-	-					
30GSE	220	60	CFM	701	657	633	600	585	187	-	-	-	1,400	48	44		
			Sones	3.8	3.6	3.6	3.5	3.6	8.6	-	-	-					
35GSE	220	60	CFM	1,308	1,247	1,217	1,184	1,153	772	-	-	-	1,460	129	119		
			Sones	9.0	9.0	9.1	9.0	9.1	9.4	-	-	-					
40GSE	220	60	CFM	1,177	1,119	1,090	1,058	1,026	561	243	-	-	1,315	106	98		
			Sones	5.5	5.5	5.6	5.6	5.8	11.1	12.0	-	-					
45GSC	220	60	CFM	1,850	1,788	1,752	1,712	1,669	1,456	600	-	-	1,640	178	161		
			Sones	11.9	11.6	12.0	12.4	13.6	14.6	13.4	-	-					
50GSC	220	60	CFM	1,615	1,548	1,506	1,458	1,411	1,147	390	-	-	1,435	130	122		
			Sones	8.6	8.2	8.2	8.0	8.0	12.6	13.4	-	-					
55GSC	220	60	CFM	2,677	2,581	2,535	2,488	2,440	2,170	2,050	-	-	1,550	294	270		
			Sones	20.0	20.0	19.7	19.4	19.3	18.9	19.9	-	-					
60GSC	220	60	CFM	2,135	2,067	2,035	2,000	1,965	1,800	1,480	-	-	1,440	164	151		
			Sones	9.0	8.5	8.7	8.7	8.7	13.0	14.2	-	-					

Performance certified is for installation type A: Free inlet, Free outlet with partition. Performance ratings do not include the effects of appurtenances (accessories). The sound ratings shown are loudness values in fan sonas at 5 ft. (1.5m) in a hemispherical free field calculated per AMCA International Standard 301. Values shown are for installation type A: Free inlet hemispherical sone levels. Performance is based on actual speed of test. \*the Watts rating is only for AMCA test method and it is at the static pressure of 0 inch of H<sub>2</sub>O.  
 \*\*the Watts rating is only for IEC test method.

Model	Voltage [V]	Frequency [Hz]	CFM / SONE AT STATIC Pressure (ps-inches of H <sub>2</sub> O)				RPM	Watts*		Watts**	
			Inches of H <sub>2</sub> O	0	0.2	0.3		0.4	FOR AMCA	FOR IEC	
45GSC	220	60	CFM	3,278	3,131	3,001	2,795	1,563	346	325	
			Sones	10	10.4	10.6	10.8				
50GSC	220	60	CFM	2,854	2,648	2,454	2,030	1,430	277	241	
			Sones	7.8	7.7	7.8	9.4				
55GSC	220	60	CFM	3,884	3,443	3,090	2,501	1,080	347	326	
			Sones	10.9	11.3	11.5	11.8				
60GSC	220	60	CFM	3,354	2,854	2,266	912	968	293	271	
			Sones	11.7	13.8	14.5	15.4				
65GSC	220	60	CFM	5,038	4,349	3,943	3,560	1,088	384	361	
			Sones	10.1	9.8	9.5	10.1				
70GSC	220	60	CFM	4,402	3,855	3,366	2,972	980	289	263	
			Sones	10.3	8.6	8.5a	11.5				

Performance certified is for installation type A: Free inlet, Free outlet with partition. Performance ratings do not include the effects of appurtenances (accessories). The Speed (RPM) and Watts rating shown are at the static pressure of 0 inch of H<sub>2</sub>O. The sound ratings shown are loudness values in fan sonas at 5 ft. (1.5m) in a hemispherical free field calculated per AMCA International Standard 301. Values shown are for installation type A: Free inlet hemispherical sone levels. \*the Watts rating is only for AMCA test method and it is at the static pressure of 0 inch of H<sub>2</sub>O.  
 \*\*the Watts rating is only for IEC test method.

## Industrial Type Ventilation Fan (Non-AMCA Certified)

Model	Phase	Voltage [V]	Frequency [Hz]	Consumption [W]	RPM	Air Volume		Noise [dB(A)]	Weight [kg]
						[CMH]	[CFM]		
45GTC	3	380	50	220	1,450	5,520	3,249	52	18.5
			60	330	1,690	6,420	3,779	56	
50GTC	3	380	50	320	1,400	6,960	4,097	54	28.5
			60	475	1,590	8,010	4,715	58	
60GTC	3	380	50	310	940	9,420	5,544	49	34
			60	450	1,070	10,920	6,427	53	

Model	Voltage [V]	Frequency [Hz]	Air Volume		Current [A]	Input [W]	Noise [dB(A)]	RPM	Weight [kg]	Installation Space W x L [mm]
			m <sup>3</sup> /h	ft <sup>3</sup> /min						
40KAQA	220	50	1,880	1,105	0.260	47.0	51.0	1,230 ~ 1,370	6.4	444 x 444
			1,920	1,130	0.270	52.0	51.0	1,250 ~ 1,390		
	240	60	1,960	1,155	0.290	59.0	51.0	1,270 ~ 1,410		
			2,130	1,254	0.310	67.0	52.5	1,400 ~ 1,540		

Note:  
 The value in specification tables are representative characteristic value at 220V, 50/60Hz.  
 RPM data is for reference only. Values may vary subject to different conditions.  
 The above Industrial Ventilating Fan Model are not licensed to bear the AMCA Certified Rating Seal.

# Ventilation Product Specification Summary

## Wall Mount Type Ventilation Fan (AMCA Certified)

Series	Model	Voltage [V]	Frequency [Hz]	CFM/SONE AT STATIC Pressure (ps-inches of H <sub>2</sub> O)				RPM	Watts* FOR AMCA	Watts** FOR IEC
				inches of H <sub>2</sub> O	0	0.025	0.05			
Metallic	20ASB	220	60	CFM Sones	330 1.7	259 1.9	183 3.9	1,358	25.5	21.5
		240	50	CFM Sones	296 1.5	198 1.7	151 3.2	1,252	22.4	19.5
	20ASB 05	240	50	CFM Sones	296 1.5	198 1.7	151 3.2	1,252	22.4	19.5
	25ASB	220	60	CFM Sones	522 1.9	414 1.6	240 2.2	1,277	35.5	30.5
		240	50	CFM Sones	486 2.0	434 2.0	314 2.4	1,194	35.1	29.5
	25ASB 05	240	50	CFM Sones	486 2.0	434 2.0	314 2.4	1,194	35.1	29.5
	30ASB	220	60	CFM Sones	637 2.0	400 2.7	85 2.2	1,088	39.8	34.5
		240	50	CFM Sones	706 2.9	620 2.3	498 2.2	1,175	38.1	34
	30ASB 05	240	50	CFM Sones	706 2.9	620 2.3	498 2.2	1,175	38.1	34
Automatic Shutter	15AAQ1	220	60	CFM Sones	157 2.5	122 1.9	65 2.3	1,533	20.6	19
		240	50	CFM Sones	154 1.7	120 1.4	63 2.1	1,453	20.1	19
	20AUH	220	60	CFM Sones	355 2.5	314 2.5	196 1.7	1,410	32.4	28.5
	25AUH	220	60	CFM Sones	514 1.8	426 1.5	290 1.8	1,200	37.8	33
	30AUH 11	220	60	CFM Sones	572 1.0	453 1.7	235 2.6	856	37.0	33
Automatic Shutter Louver	20ALH	220	60	CFM Sones	328 3.5	280 3.2	170 3.4	1,385	32.8	28.5
	25ALH	220	60	CFM Sones	420 2.7	372 2.7	232 4.6	1,097	37.5	33
	30ALH 11	220	60	CFM Sones	447 2.0	288 2.7	154 2.2	756	37.1	33

Series	Model	Voltage [V]	Frequency [Hz]	CFM/SONE AT STATIC Pressure (ps-inches of H <sub>2</sub> O)				RPM	Watts* FOR AMCA	Watts** FOR IEC	
				inches of H <sub>2</sub> O	0	0.02	0.04				0.06
Automatic Shutter	20AUA	220	60	CFM Sones	370 2.1	328 2.1	274 2.2	227 2.5	1,430	23.5	22
		240	50	CFM Sones	339 2.0	295 2.1	257 2.0	200 2.7	1,303	23	21.5
	25AUA	220	60	CFM Sones	542 2.4	504 2.3	460 1.9	361 2.5	1,387	33.2	31
		240	50	CFM Sones	542 3.6	493 3.2	443 3.0	394 3.1	1,252	31	29
	30AUA	220	60	CFM Sones	655 2.0	567 1.6	456 1.6	242 2.4	938	35.3	33
		240	50	CFM Sones	696 2.0	580 1.8	491 1.6	340 2.2	964	34.8	32.5
Automatic Shutter Louver	20ALA	220	60	CFM Sones	334 2.8	296 2.7	256 3.1	197 3.9	1,398	23.5	22
		240	50	CFM Sones	301 2.5	274 2.5	234 2.7	175 2.8	1,278	23	21.5
	25ALA	220	60	CFM Sones	471 3.4	411 3.2	350 2.9	250 3.0	1,224	33.2	31
		240	50	CFM Sones	482 4.2	438 4.1	389 3.8	328 3.8	1,217	32.1	30
	30ALA	220	60	CFM Sones	510 2.5	446 1.9	372 2.0	219 2.1	876	35.3	33
		240	50	CFM Sones	571 3.1	494 2.6	411 2.5	263 3.3	896	35.3	32.5

Performance certified is for installation type A: Free inlet, Free outlet with partition. Performance ratings include the effects of backdraft shutter for all models and inlet grill for Model ALA, ALH, ALF 11. Performance ratings include the effects of inlet grille and backdraft shutter for Model ALA. The speed (RPM) and Watts rating shown are at the static pressure of 0 inch of H<sub>2</sub>O. The sound ratings shown are loudness values in fan sones at 5 ft. (1.5m) in a hemispherical free field calculated per AMCA International Standard 301. Values shown are for installation type A: Free inlet hemispherical sone levels.

\*the Watts rating only for AMCA test method and it is at the static pressure of 0 inch of H<sub>2</sub>O.

\*\*the Watts rating only for ICE test method and the AMCA Certified Ratings Seal does not apply to IEC test method watts.

## Wall Mount Type Ventilation Fan (Non-AMCA Certified)

Model	Voltage		Air Volume [CMH]	Consumption [W]	RPM	Noise [dB(A)]	Weight [kg]	Installation Space [mm]	Wall Thickness [mm]
	[V]	[Hz]							
10EGKB	220	50	76	4.3	2,660	33	1.0	Ø130~140	100-150
	230	50	77	4.6	2,675	33			
	240	50	77	5.0	2,690	33			
15EGKB	220	50	162	5.7	2,265	36	1.3	Ø175~185	100-150
	230	50	165	6.1	2,330	37			
	240	50	165	6.5	2,390	37			
10EGSB	220	50	76	4.3	2,665	35	0.8	Ø120~125	>205
		60	87	4.7	3,140	37.5			
	230	50	77	4.6	2,670	35			
15EGSB	220	50	155	5.7	2,130	36	1.0	Ø165~170	>240
		60	180	6.1	2,470	40			
	230	50	160	6.1	2,230	37			
10BAQ1	220	50	76.3	15	1,250	40.1	1.7	155 x 205	-
		60	72.9	17	1,200	39.8			
	230	50	80.3	16	1,300	41.2			
240	50	84.9	17.5	1,385	42				

Note: RPM data is for reference only, values may vary subject to different conditions

Test Condition

- Air volume, electric characteristic and noise are specified at the static pressure of 0 Pa
- The values of noise level is A weighted average sound pressure level, the mean values are measured by our company, within +3 to -7 dB tolerance
- The values of noise level are measured at 1 m apart from the side of fan body when ducts are connected on outlet side
- The values of air volume are the mid-points of results measured by our company, within ±10% tolerance

# Ventilation Product Specification Summary

## Window Mount Type Ventilation Fan (AMCA Certified)

Model	Voltage [V]	Frequency [Hz]	CFM/SONE AT STATIC Pressure (ps-inches of H <sub>2</sub> O)				RPM	Watts*	Watts**	
			inches of H <sub>2</sub> O	0	0.05	0.1				0.15
15WHCT	220	60	CFM	127	94	63	31	2,440	14.6	13
			Sones	3.0	3.6	3.5	3.9			
20WHCT	220	60	CFM	250	188	127	78	1,517	24.4	22
			Sones	3	3.9	4.5	4.2			
20WHCT	240	50	CFM	230	147	103	53	1,333	23.4	22
			Sones	2.8	3.8	3.4	4			

Model	Voltage [V]	Frequency [Hz]	CFM/SONE AT STATIC Pressure (ps-inches of H <sub>2</sub> O)				RPM	Watts*	Watts**	
			inches of H <sub>2</sub> O	0	0.02	0.04				0.06
15WAA 15WAAMN	220	60	CFM	124	109	91	79	2,021	19.6	18
			Sones	3.6	4.5	4.1	4			
20WAA 20WAAMN	220	60	CFM	250	147	124	94	1,385	18.4	17
			Sones	3	3.8	3.5	3.3			
20WAA 20WAAMN	240	50	CFM	230	153	141	131	1,375	18.6	17.5
			Sones	2.8	3.3	3.4	3.4			

Model	Voltage [V]	Frequency [Hz]	CFM/SONE AT STATIC Pressure (ps-inches of H <sub>2</sub> O)				RPM	Watts*	Watts**	
			inches of H <sub>2</sub> O	0	0.01	0.02				0.03
15WUD 15WUDMN	220	60	CFM	105	94	79	66	1,425	9.7	8.9
			Sones	0.9	0.9	2.2	2.4			
20WUD 20WUDMN	220	60	CFM	188	129	112	88	980	19.2	17.9
			Sones	0.8	1.2	1.8	1.4			
20WUD 20WUDMN	240	50	CFM	221	168	141	118	1,096	18.5	17.2
			Sones	1.8	1.6	2.2	2.0			

Performance certified is for installation type A: Free inlet, Free outlet with partition. Performance ratings include the effects of backdraft shutter for all models and inlet grill for Model 15WHCT and 20WHCT. The Speed (RPM) and Watts rating shown are at the static pressure of 0 inch of H<sub>2</sub>O. The sound ratings shown are loudness values in fan sones at 5 ft. (1.5m) in a hemispherical free field calculated per AMCA International Standard 301. Values shown are for installation type A: Free Inlet hemispherical sone levels.

\* the Watts rating is only for AMCA test method and it is at the static pressure of 0 inch of H<sub>2</sub>O.

\*\* the Watts rating is only for IEC test method and the AMCA Certified Ratings Seal does not apply to IEC test method watts.

## Energy Recovery Ventilator (AMCA Certified)

Model	Voltage [V]	Frequency [Hz]	CFM / SONE AT STATIC Pressure (ps-inches of H <sub>2</sub> O)												RPM	Watts*	Watts**
			Inches of H <sub>2</sub> O	0	0.1	0.125	0.25	0.375	0.5	0.75	1	1.25	1.5	1.75			
E25DZUA	220	60	CFM (OA-SA)	183	172	168	155	143	131	108	77	14	-	-	1,448	197	171
			CFM (RA-EA)	130	118	115.5	104	91	77	44	0	-	-	-			
E35DZUA	220	60	CFM (OA-SA)	258	250	247	237	225	211	174	144	118	69	-	1,425	348	310
			CFM (RA-EA)	192	183	180	169	157	144	116	84	49	0	-			
E50DZUA	220	60	CFM (OA-SA)	339	330	326	314	303	290	261	230	188	134	80	1,501	470	406
			CFM (RA-EA)	253	241	238	224	207	190	154	117	82	41	-			

Performance certified is for installation type D-Ducted inlet, Ducted outlet. Speed (RPM) shown is nominal. Performance is based on actual speed of test. Performance ratings do not include the effects of appurtenances (accessories).\*

Air performance ratings for gross supply airflow are from port 2. Air performance ratings for gross exhaust airflow are to port 3.

\* The Watts rating is only for AMCA test method and it is at the static pressure of 0 inch of H<sub>2</sub>O.

\*\* The Watts rating is only for IEC test method and AMCA Certified Rating Seal does not apply to IEC test method watts.

Main Body	Size (mm)	650 x 750 x 220	680 x 920 x 230	680 x 1090 x 240
	Weight	30	39	45
	OA Side Duct Diameter	Ø200		
	Duct Diameter RA/SA/EA	Ø150		

Up-Side Down Installation	Up-Side Down Installation
---------------------------	---------------------------

Filter Box	Duct Diameter	Ø200	
	Size (mm)	600 x 385 x 240	600 x 385 x 350

# Ventilation Product Specification Summary

## Mini Sirocco Fan (Non-AMCA Certified)

Model	Voltage [V]	Frequency [Hz]	Speed	Air Volume [CMH]	Consumption [W]	Noise Level [dB]		Net Weight [kg]
						Inlet	Side	
10CGB	220	50	Hi	154	15	41.0	28.0	1.9
			Lo	115	12	35.5	24.0	
		60	Hi	133	12	36.5	24.0	
			Lo	93	9	28.5	20.0	
	230	60	Hi	143	13	38.0	25.0	
			Lo	100	10	30.5	20.0	
	220-240	50	Hi	134-143	10-11	37.0-39.0	23.0-25.0	
			Lo	110-125	9-10	32.0-35.0	20.0-23.0	
12CGB	220	50	Hi	250	22	44.0	29.0	2.5
			Lo	175	16	32.0	19.0	
		60	Hi	225	25	42.5	29.0	
			Lo	145	18	32.0	21.0	
	230	60	Hi	242	27	44.0	30.0	
			Lo	153	19	34.0	21.5	
	220-240	50	Hi	233-262	23-28	44.5-46.5	29.0-32.0	
			Lo	156-175	19-23	33.0-36.0	18.0-20.0	
14CGB	220	50	Hi	332	35	50.0	34.0	2.8
			Lo	226	28	40.0	26.0	
		60	Hi	260	30	43.0	30.0	
			Lo	200	25	35.5	25.0	
	230	60	Hi	275	33	44.5	31.5	
			Lo	212	28	37.5	26.0	
	220-240	50	Hi	280-315	28-32	44.5-46.5	31.0-33.0	
			Lo	227-265	26-30	40.0-44.0	27.0-31.0	
16CGB	220	50	Hi	509	50	49.0	35.0	5.6
			Lo	405	43	43.5	30.0	
		60	Hi	483	57	48.0	32.0	
			Lo	372	44	41.0	27.0	
	230	60	Hi	503	61	49.0	34.5	
			Lo	393	48	42.5	29.0	
	220-240	50	Hi	509-542	50-56	49.0-51.5	35.0-38.0	
			Lo	405-450	43-48	43.5-46.0	30.0-32.0	

## Mini Sirocco Fan (Non-AMCA Certified)

Model	Voltage [V]	Frequency [Hz]	Speed	Air Volume [CMH]	Consumption [W]	Noise Level [dB]		Net Weight [kg]
						Inlet	Side	
17CGB	220	50	Hi	791	86	50.0	36.0	10.1
			Lo	640	70	44.0	31.0	
		60	Hi	752	95	49.0	34.0	
			Lo	612	73	43.5	29.0	
	230	60	Hi	789	104	50.0	35.0	
			Lo	641	80	44.0	31.0	
	220-240	50	Hi	791-875	86-101	50.0-52.5	36.0-39.0	
			Lo	640-705	70-83	44.0-47.0	31.0-32.0	
19CGB	220	50	Hi	947	121	55.0	41.0	10.2
			Lo	857	105	51.5	37.0	
		60	Hi	885	127	52.0	39.0	
			Lo	760	107	48.0	37.0	
	230	60	Hi	931	140	53.5	40.0	
			Lo	791	117	49.5	36.5	
	220-240	50	Hi	919-997	113-130	52.0-54.0	40.0-42.0	
			Lo	804-880	99-115	50.0-52.0	38.0-40.0	
21CGB	220	50	Hi	1420	238	67.0	54.0	14.6
			Lo	1143	182	60.0	47.0	
		60	Hi	1500	328	68.0	57.0	
			Lo	1042	215	58.0	47.0	
	230	60	Hi	1550	342	69.0	57.5	
			Lo	1100	230	59.5	48.0	
	220-240	50	Hi	1420-1435	238-247	66.0-67.0	54.0-55.0	
			Lo	1143-1220	182-197	60.0-62.5	47.0-51.0	

**Notes:**

- ① The values of rated input, air volume and noise are specified at the static pressure of 0 Pa.
- ② The values of noise level is A weighted average sound pressure level, the mean values are measured by our company, within +3 and -7 tolerance.
- ③ The values of noise level are measured at the 1.5m apart from the inspection panel of the fan body when ducts are connected on both inlet and outlet side. It is based on the assumption that the noise of fan body propagates to room inside.
- ④ The values of air volume are the mid-points of results measured by our company, with ±10% tolerance.

# Performance Data Summary

## Ceiling Mount Type Ventilation Fan (Non-AMCA Certified)

### DC Motor Series: 24JRB

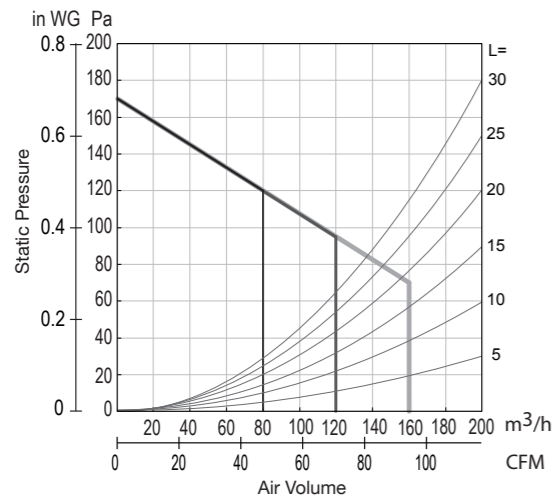

### DC Motor Series: 24JAB

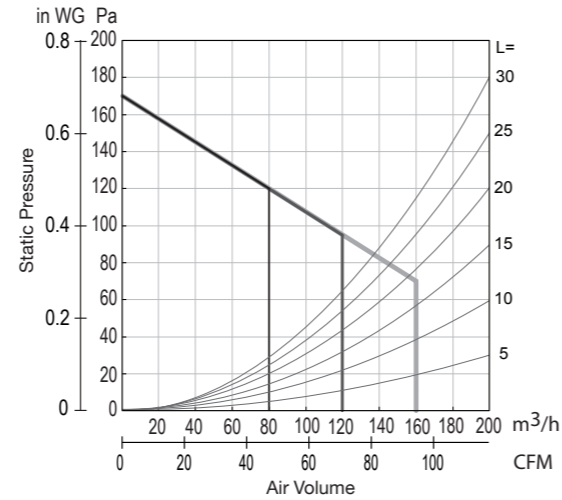

### Super Quiet Series: 17CUH

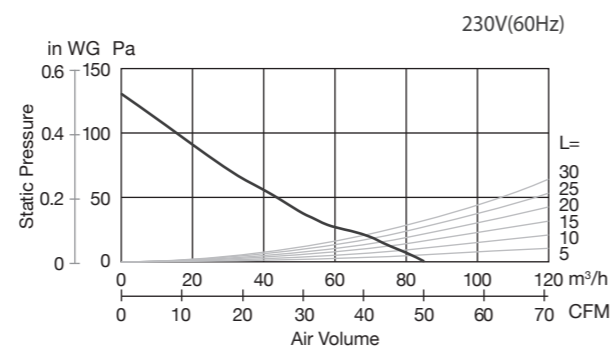
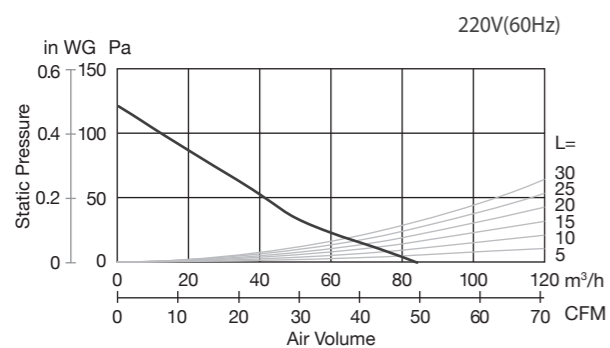
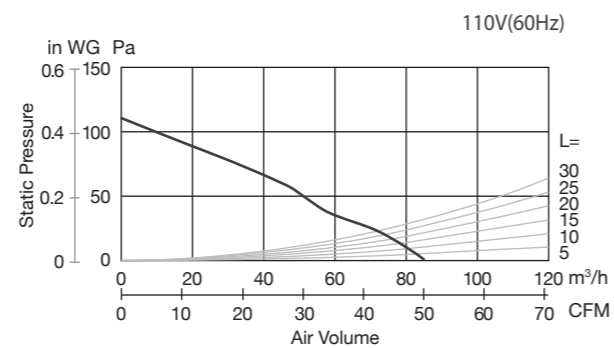
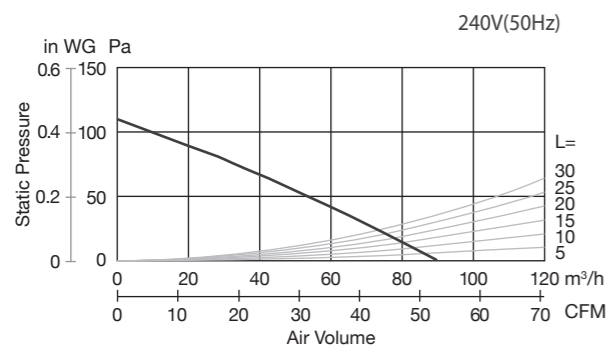
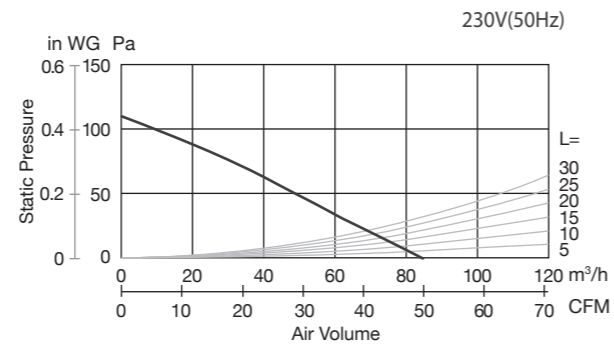
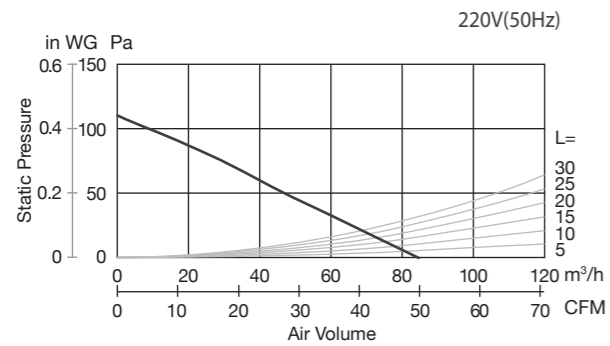

## Ceiling Mount Type Ventilation Fan (Non-AMCA Certified)

### Super Quiet Series: 24CUH

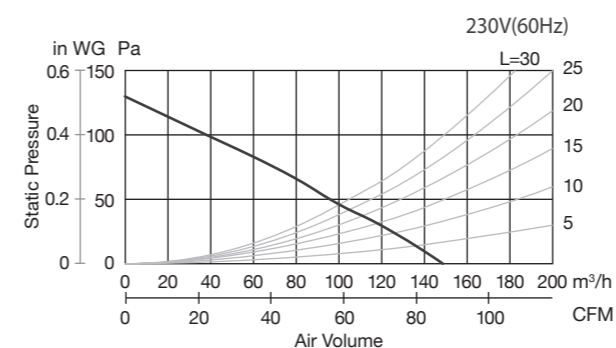
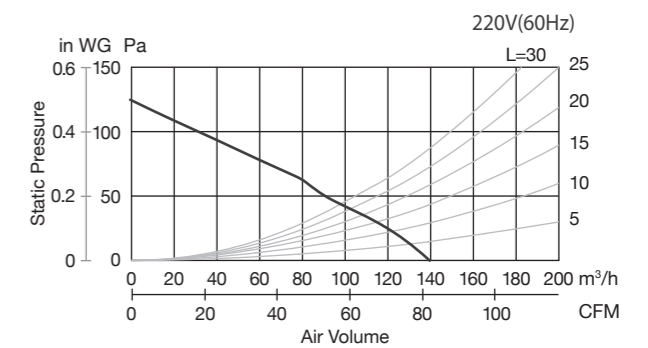
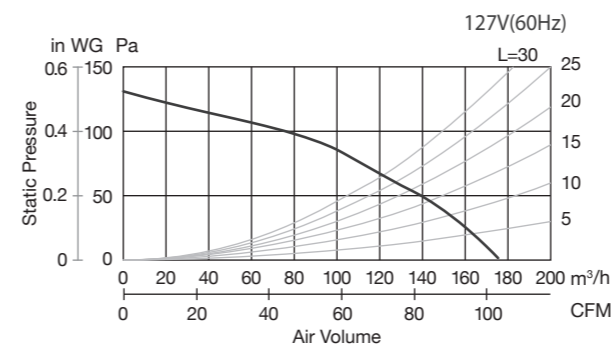
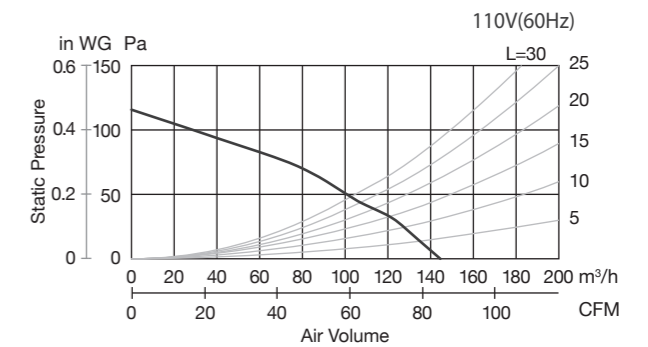
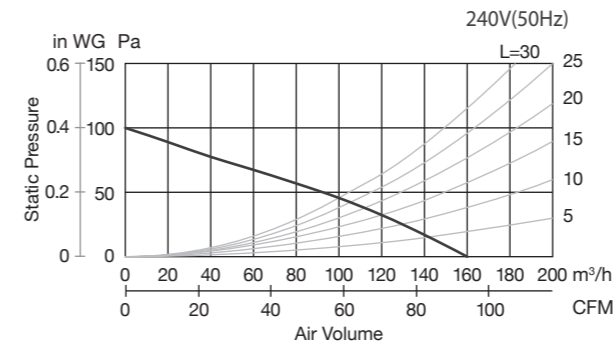
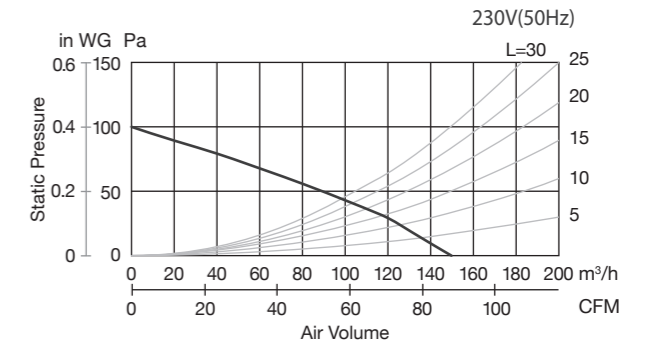
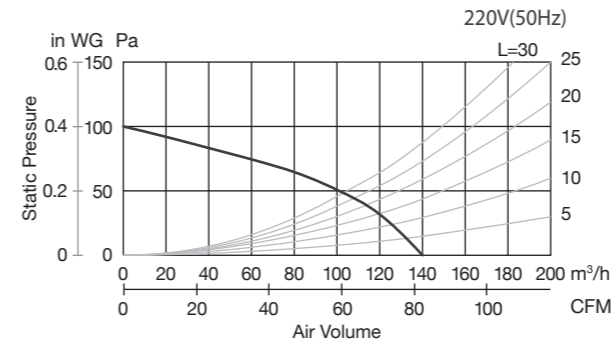

# Performance Data Summary

## Ceiling Mount Type Ventilation Fan (Non-AMCA Certified)

### Super Quiet Series: 24CDH

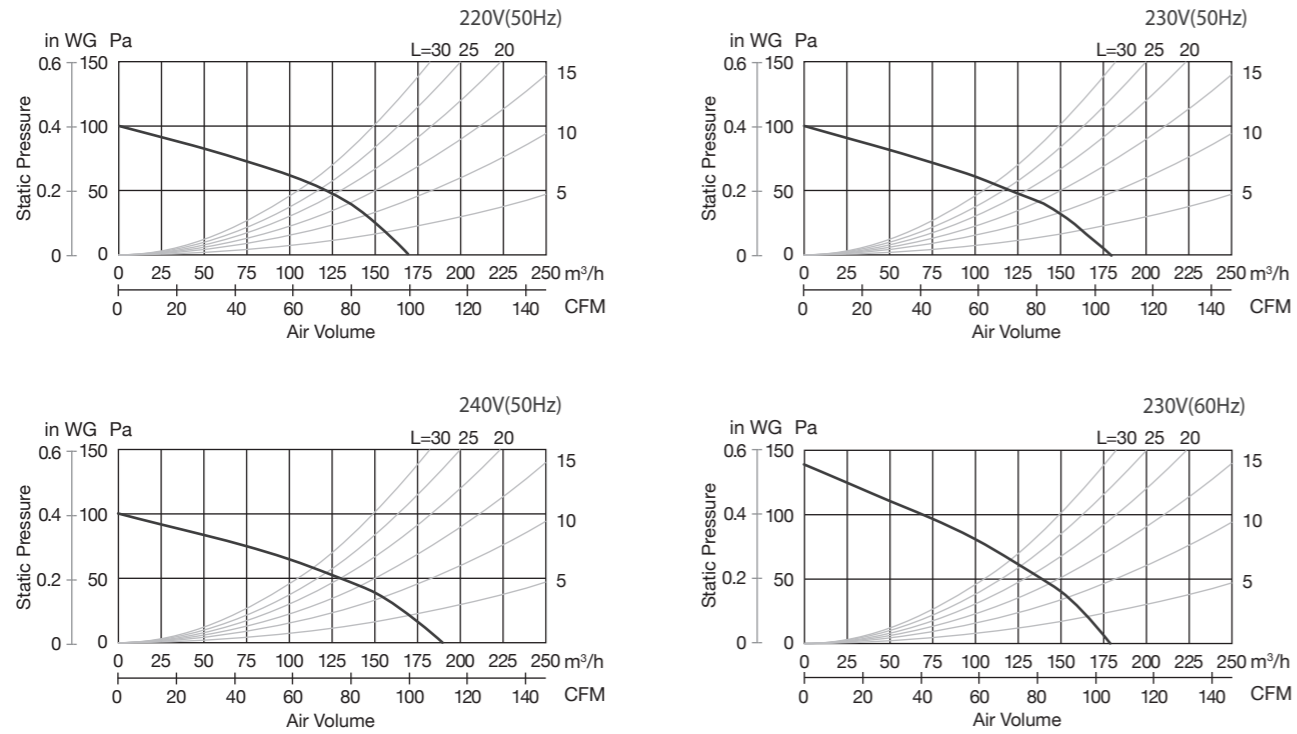

### Super Quiet Series: 24CHH

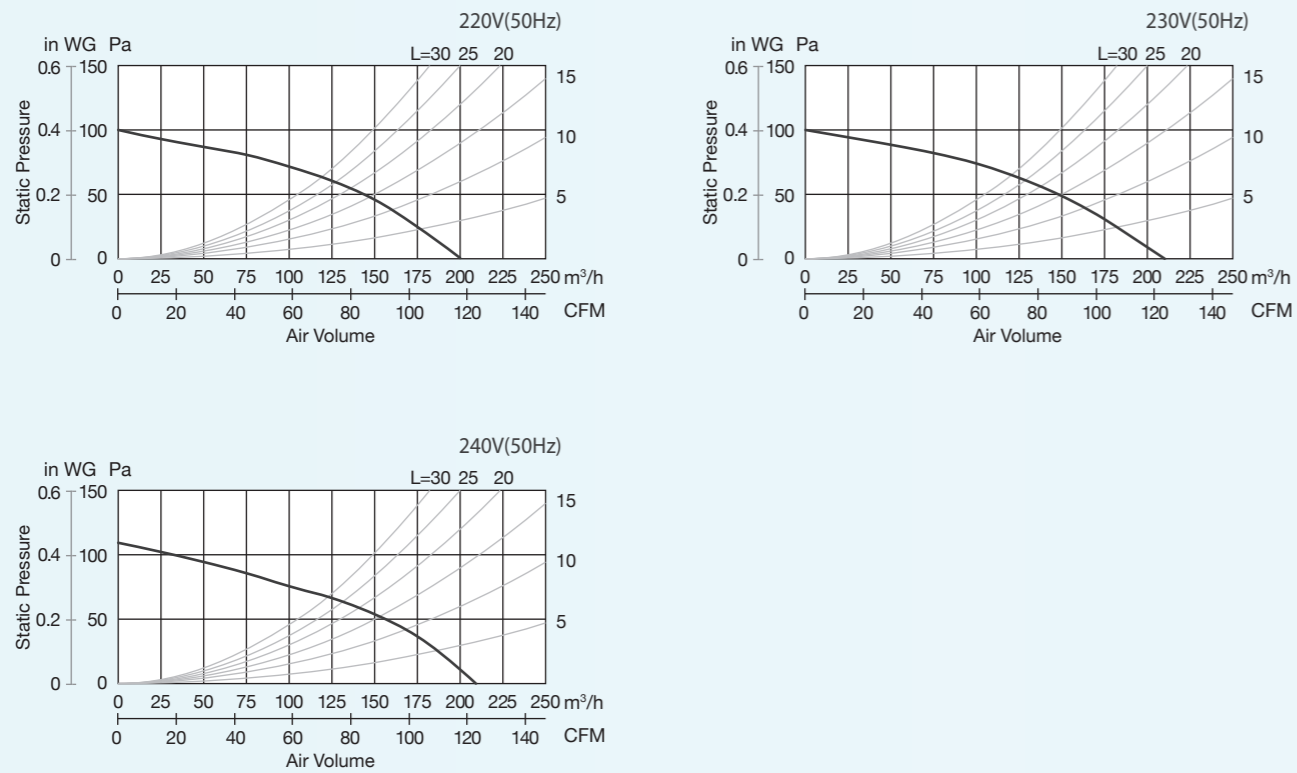

## Ceiling Mount Type Ventilation Fan (Non-AMCA Certified)

### Super Quiet Series: 24CXH

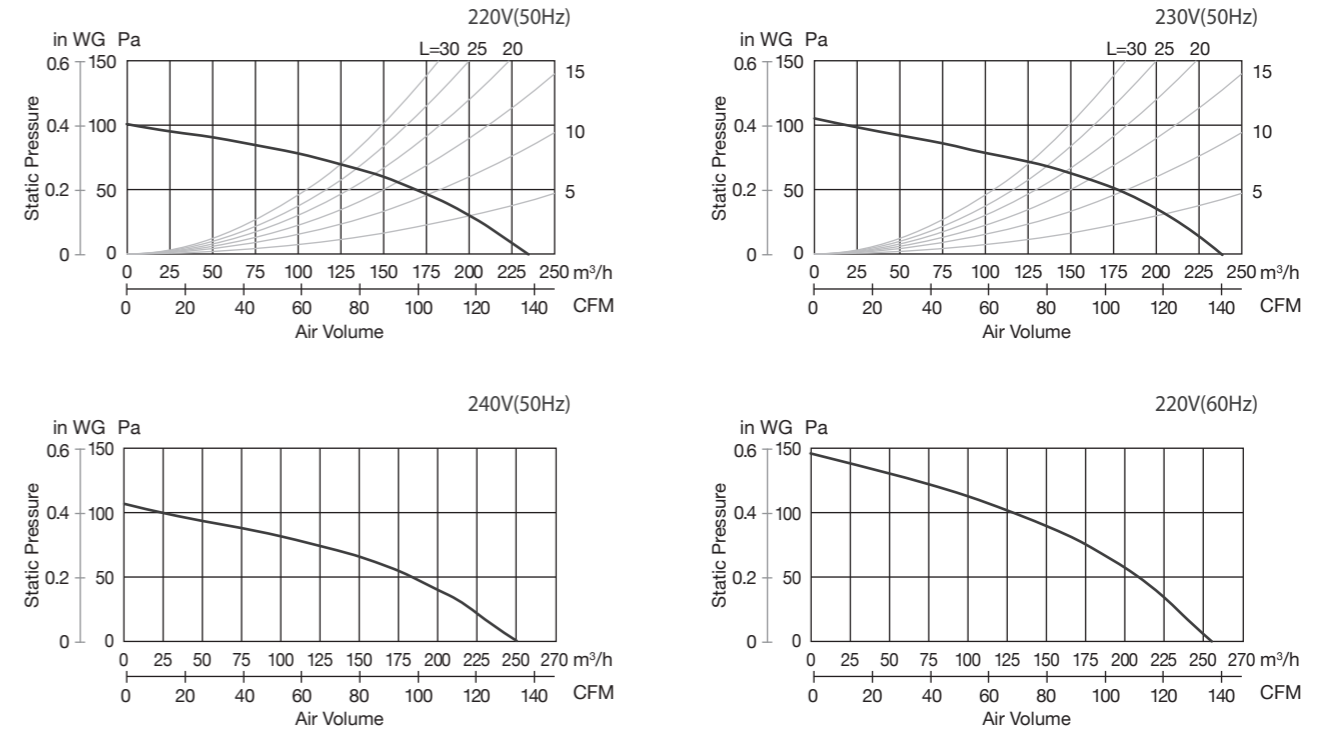

### Super Quiet Series: 24CHH

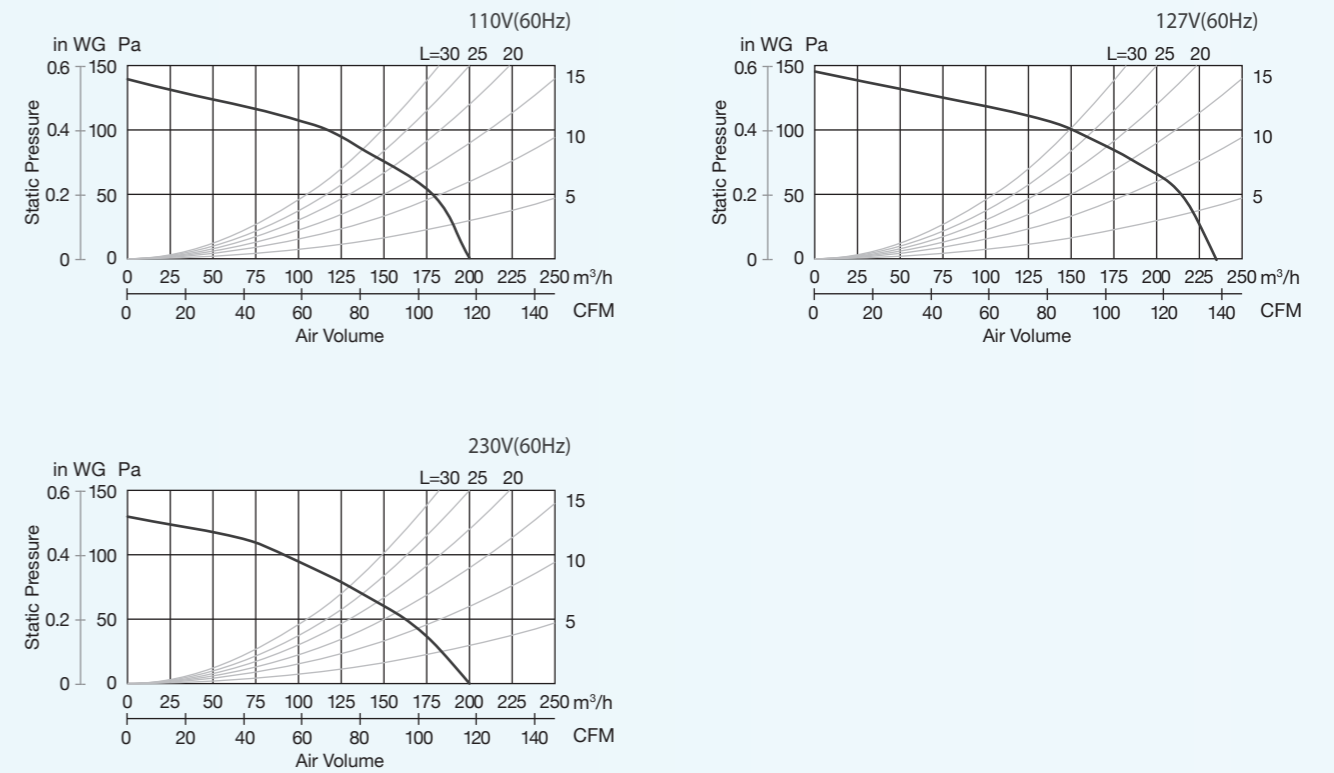

# Performance Data Summary

## Ceiling Mount Type Ventilation Fan (Non-AMCA Certified)

### Super Quiet Series: 27CHH

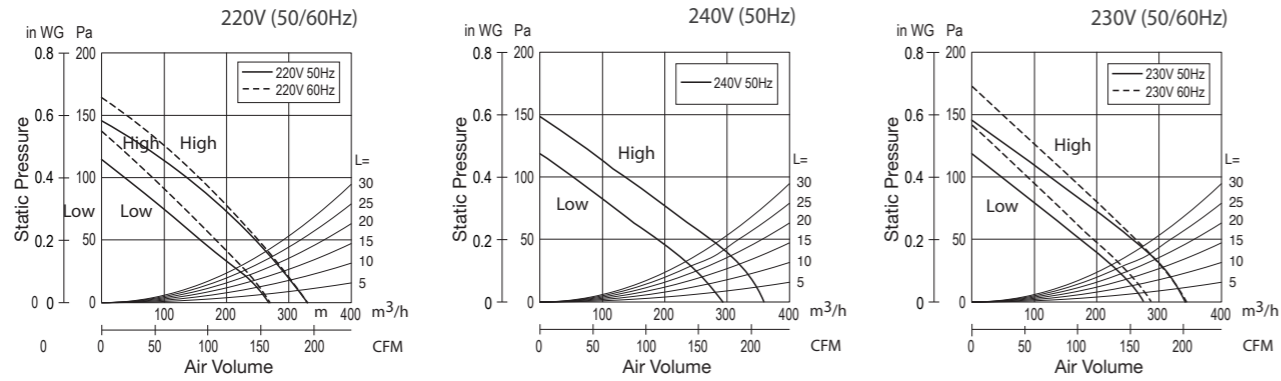

### Super Quiet Series: 32CDH

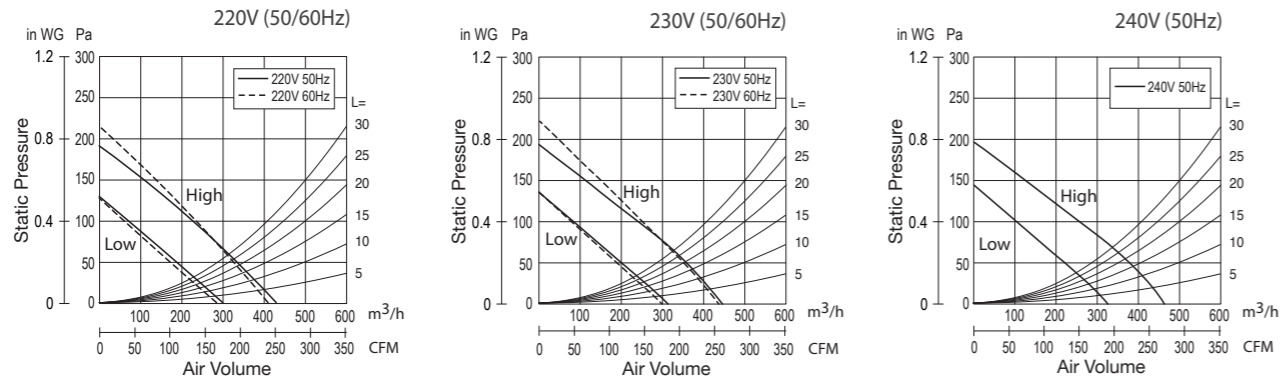

### Super Quiet Series: 32CHH

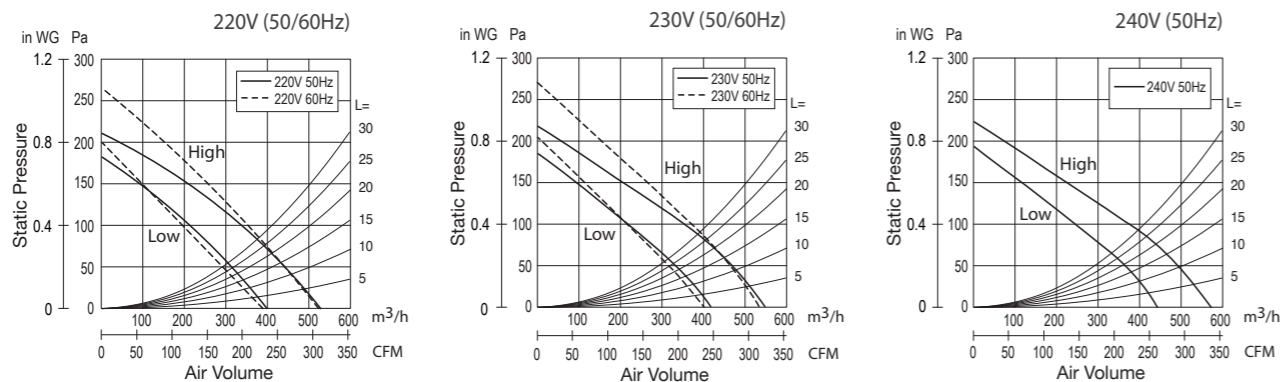

### Super Quiet Series: 38CHG

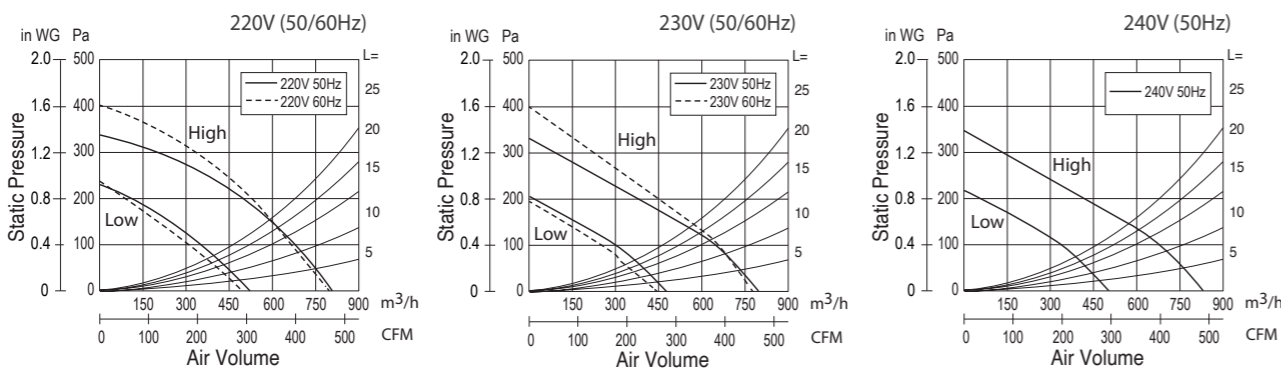

## Ceiling Mount Type Ventilation Fan (Non-AMCA Certified)

### Metal Series: 24CMUA

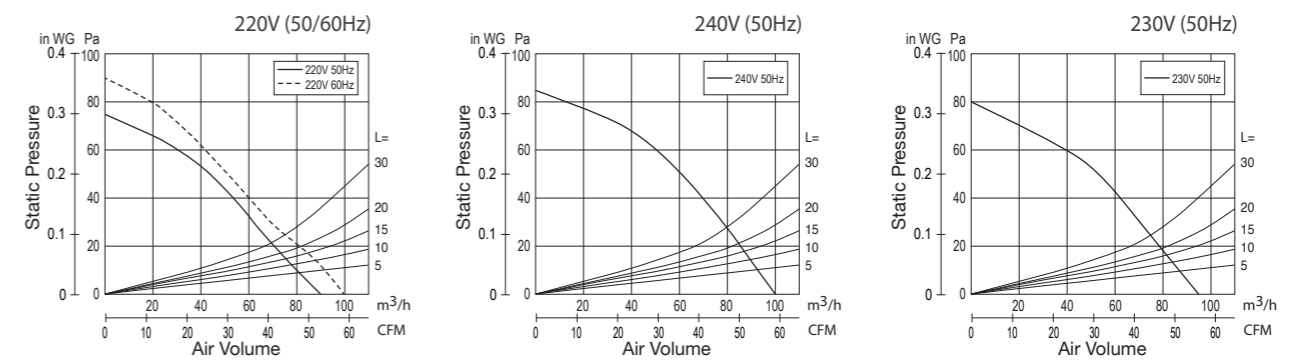

### Metal Series: 24CMHA

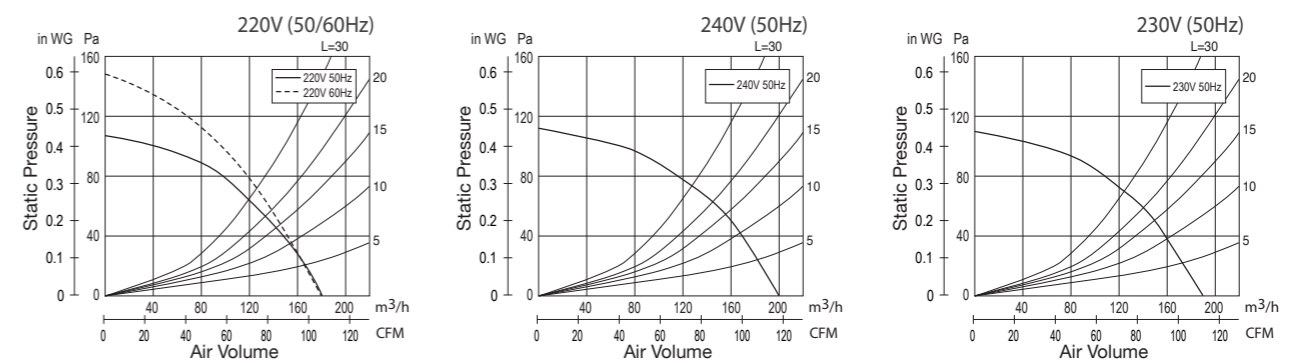

### Metal Series: 27CMHA

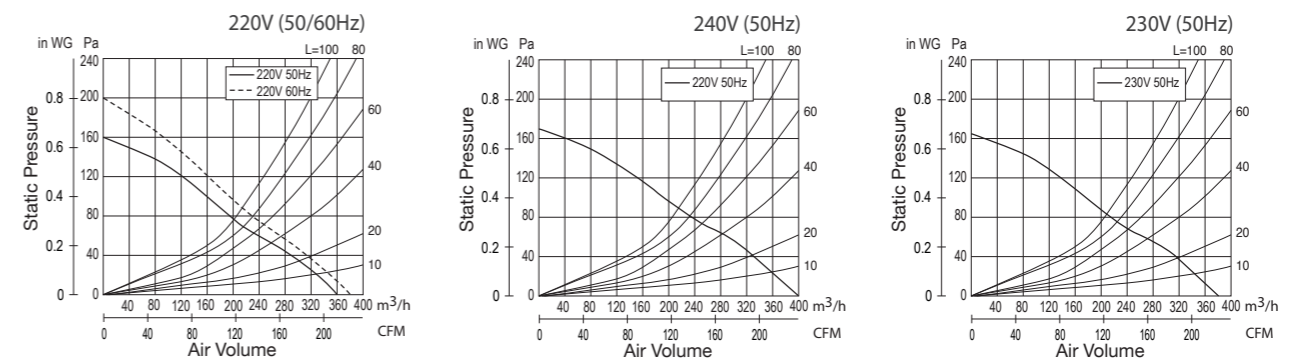

### Standard Series: 38CDG / 38CDG 05

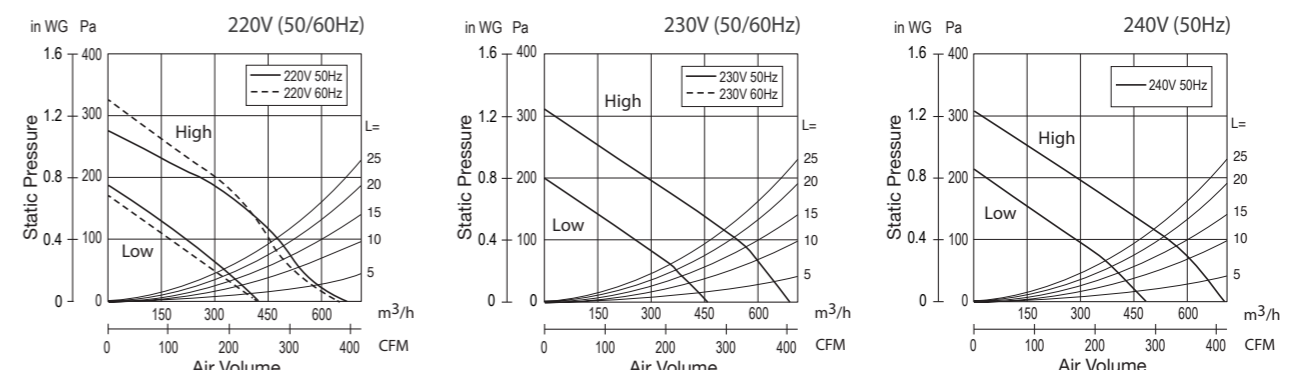

# Performance Data Summary

## Wall Mount Type Ventilation Fan (Non-AMCA Certified)

### Automatic Shutter Series: 20AUA

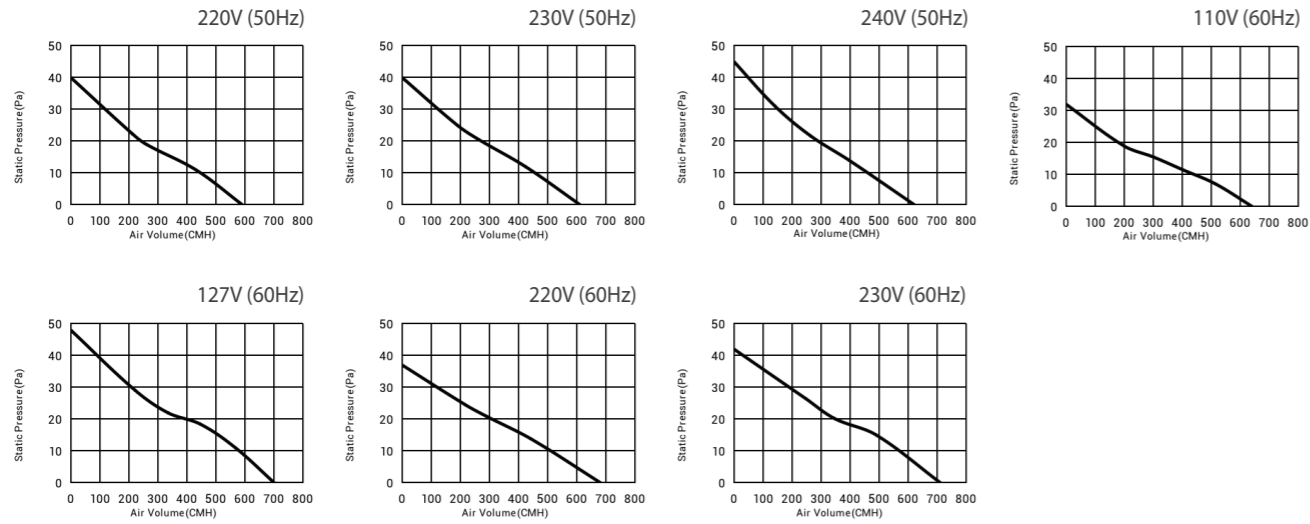

### Automatic Shutter Series: 25AUA

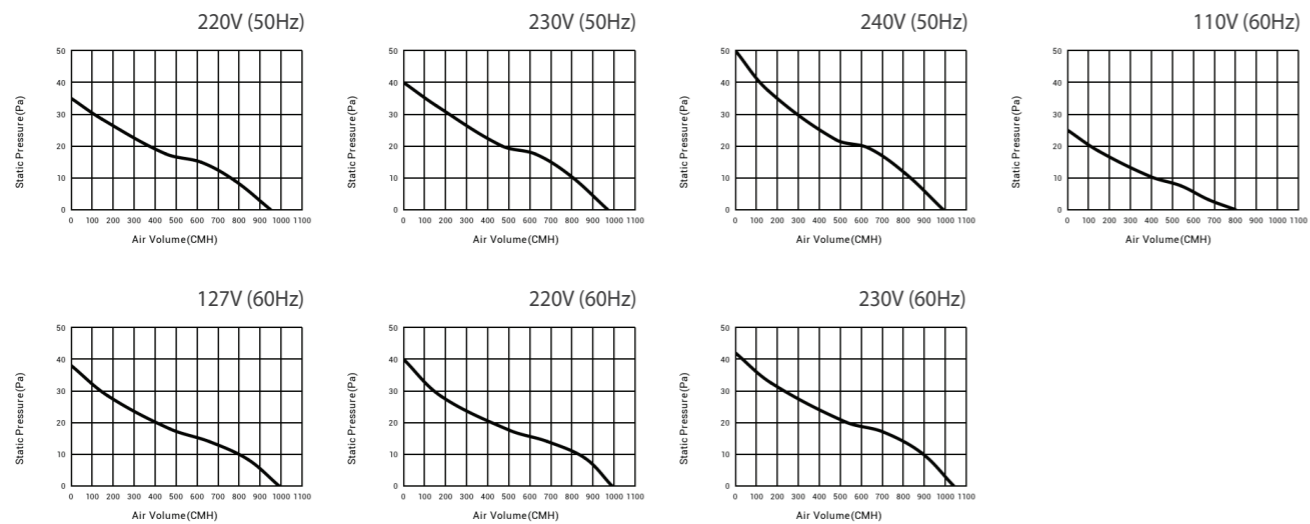

## Wall Mount Type Ventilation Fan (Non-AMCA Certified)

### Automatic Shutter Series: 30AUA

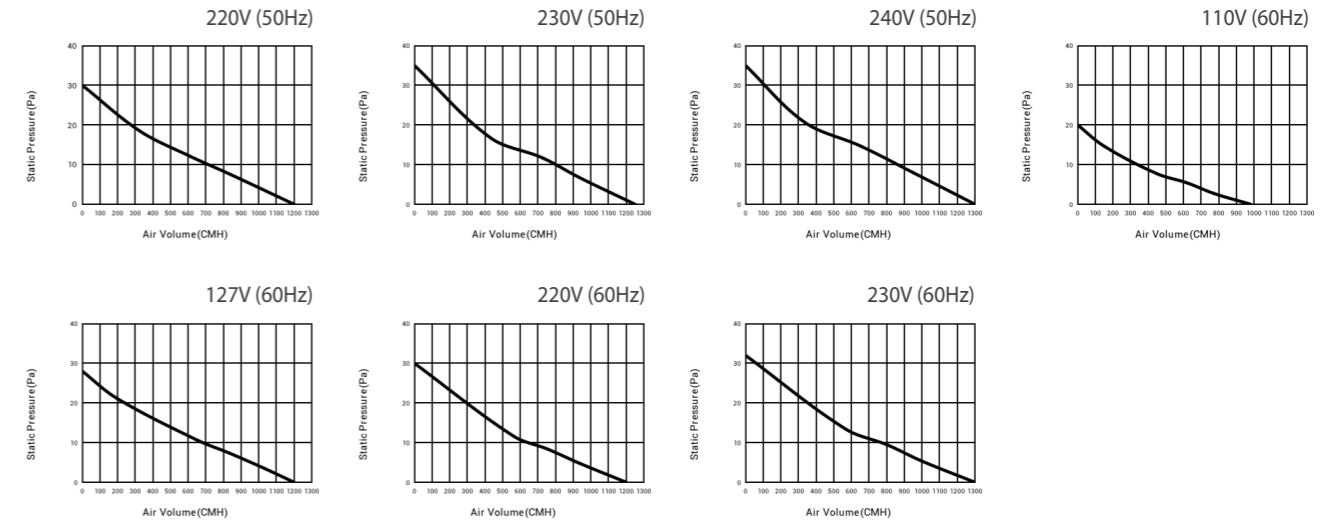

### Automatic Shutter Louver Series: 20ALA

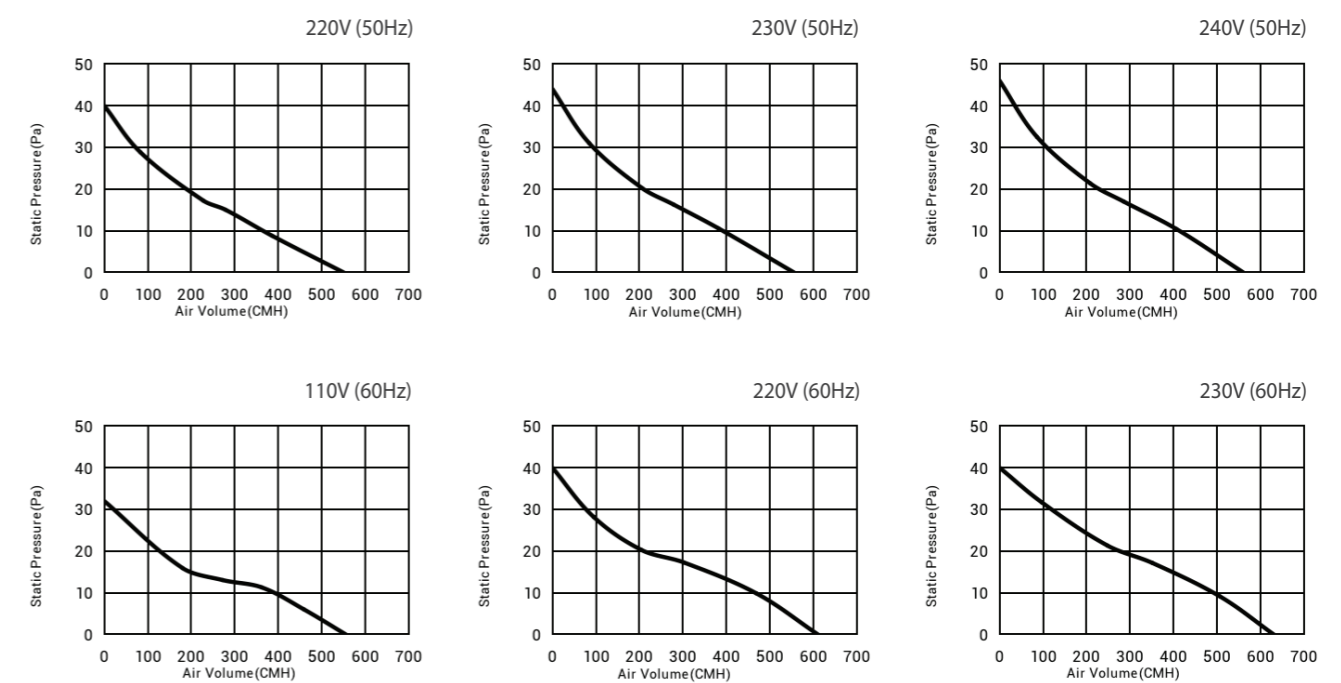

# Performance Data Summary

## Wall Mount Type Ventilation Fan (Non-AMCA Certified)

### Automatic Shutter Louver Series: 25ALA

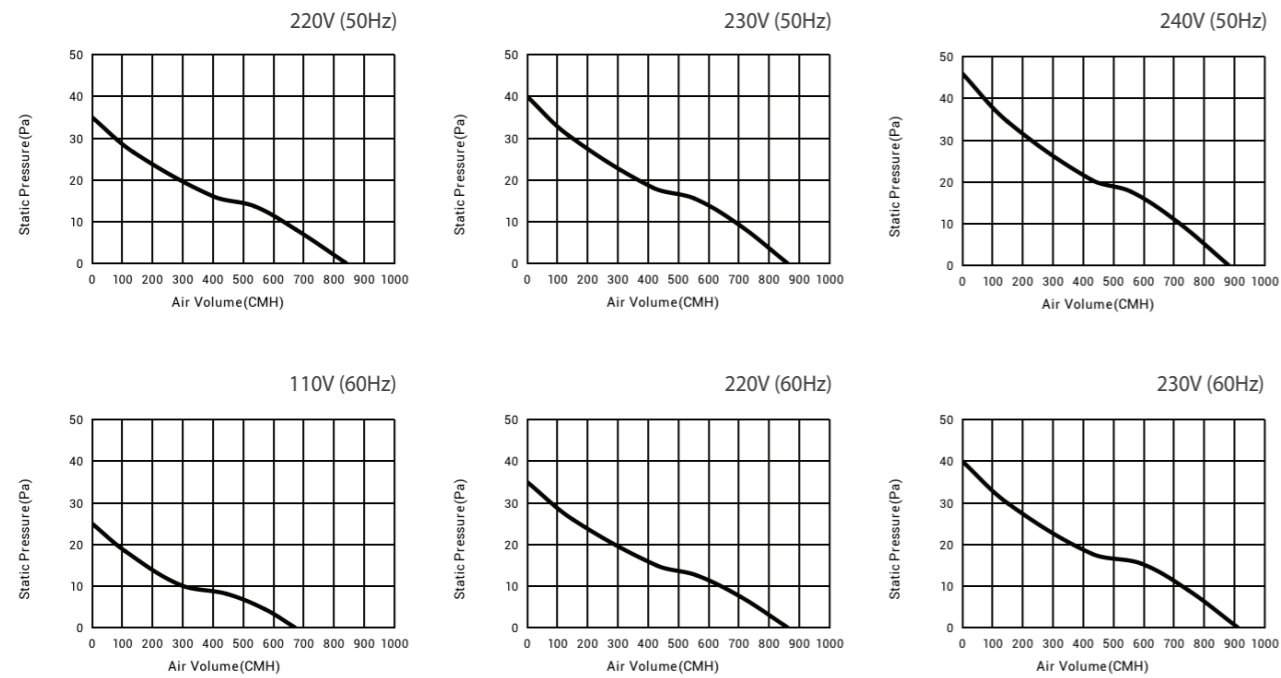

### Automatic Shutter Louver Series: 30ALA

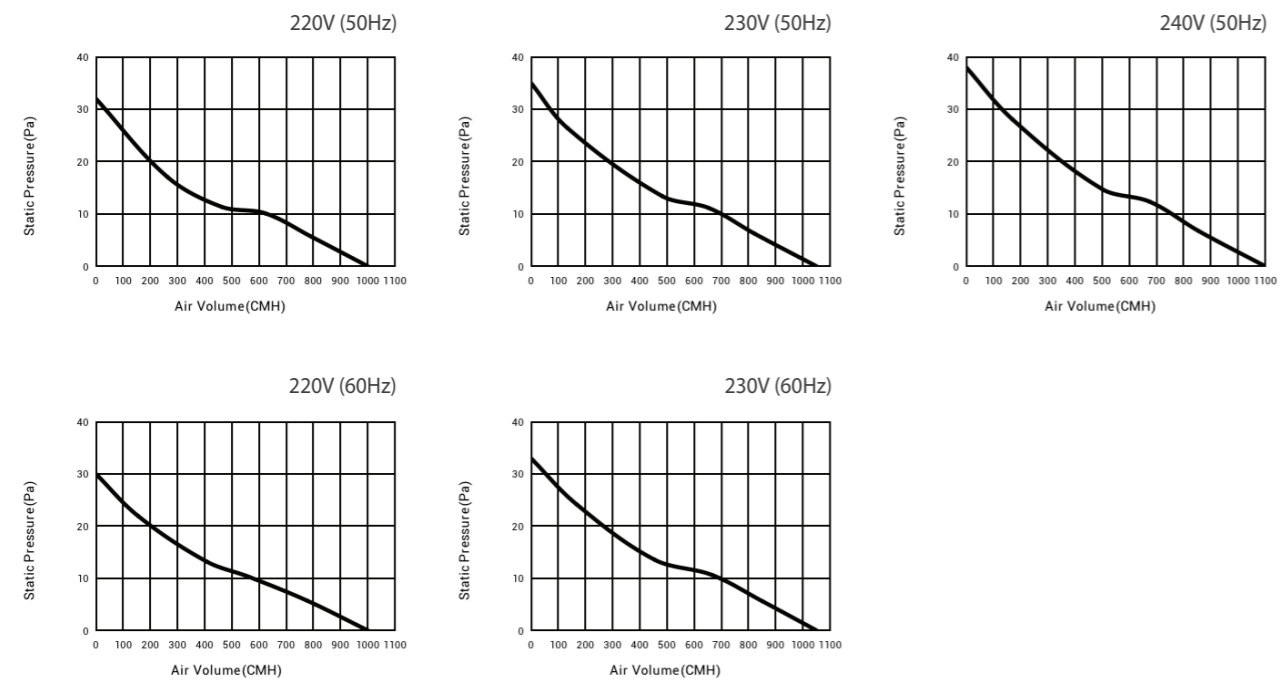

## Window Mount Type Ventilation Fan (Non-AMCA Certified)

### Electric Shutter Series: 15WHCT

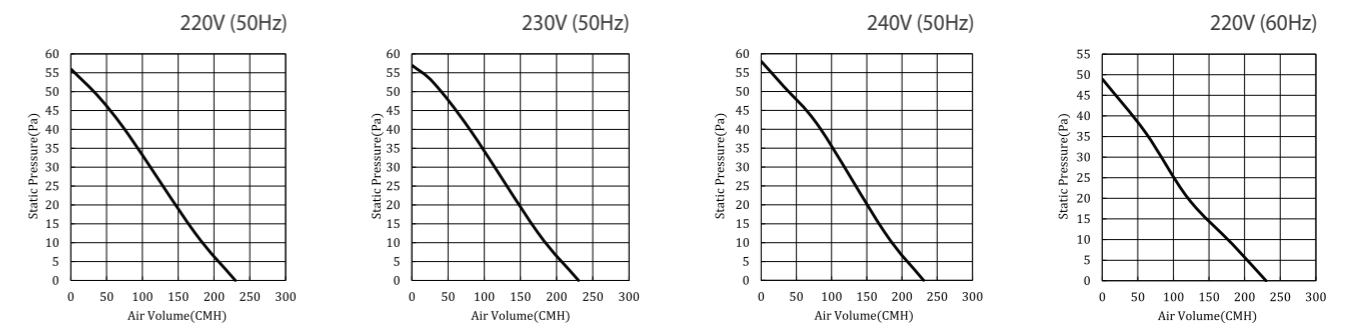

### Electric Shutter Series: 20WHCT

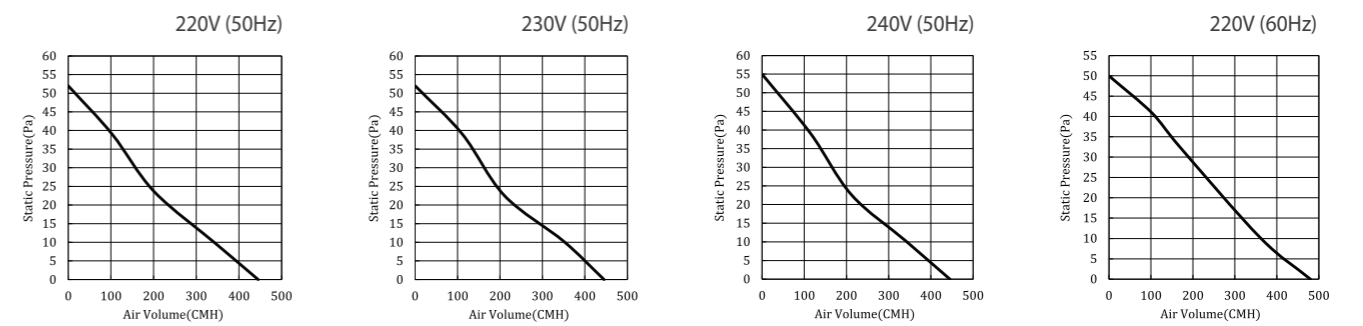

### Automatic Shutter Series: 15WAA

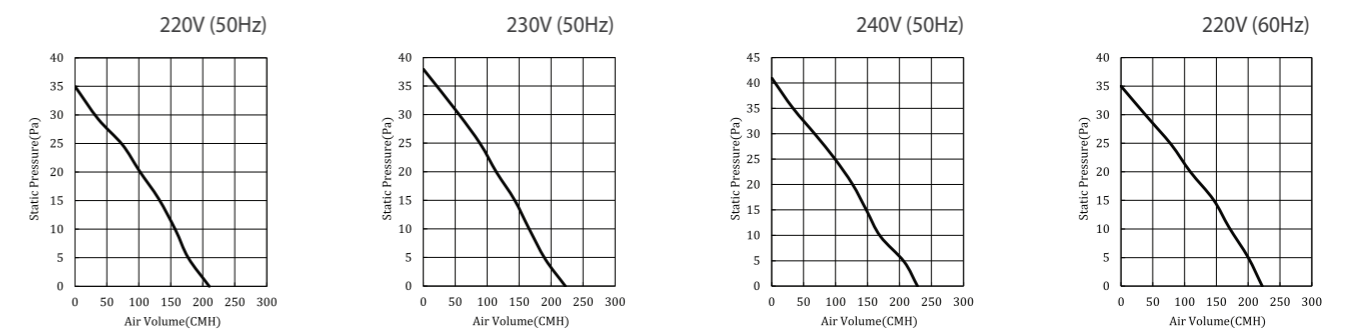

# Performance Data Summary

## Window Mount Type Ventilation Fan (Non-AMCA Certified)

### Automatic Shutter Series: 20WAA

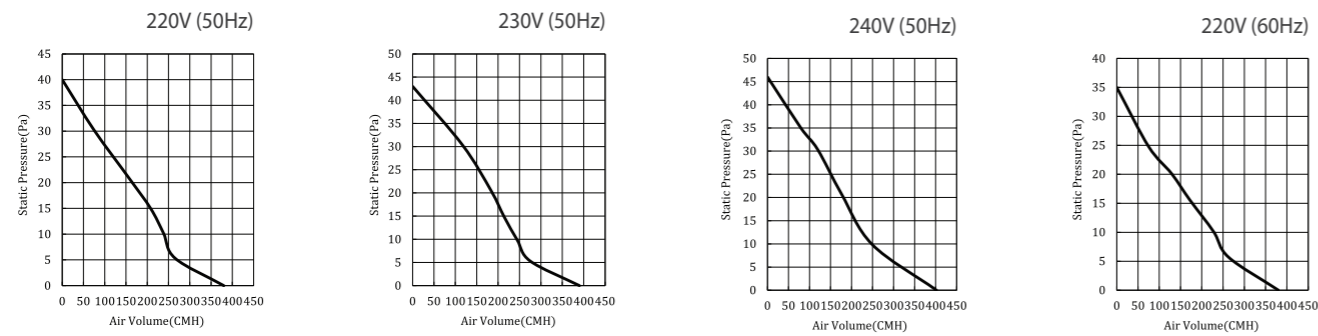

### Automatic Shutter Series: 15WAAMN

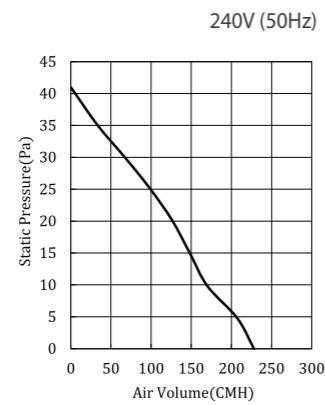

### Automatic Shutter Series: 20WAAMN

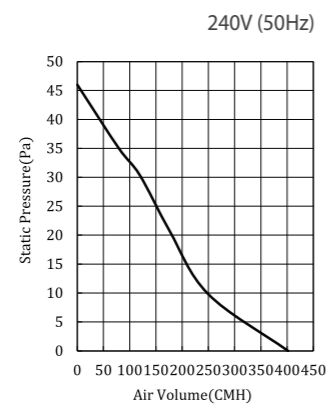

## Window Mount Type Ventilation Fan (Non-AMCA Certified)

### Cord-operated Shutter Series: 15WUD

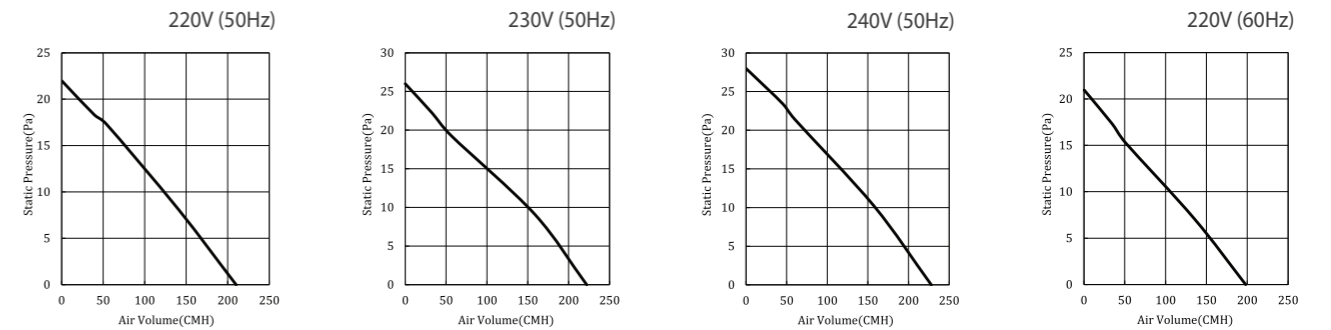

### Cord-operated Shutter Series: 20WUD

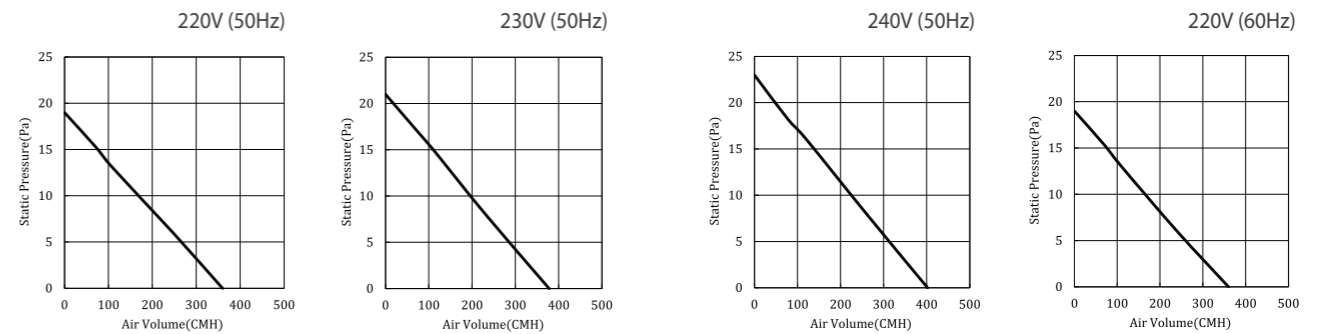

### Cord-operated Shutter Series: 15WUDMN

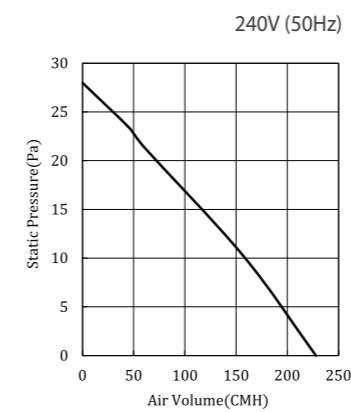

### Cord-operated Shutter Series: 20WUDMN

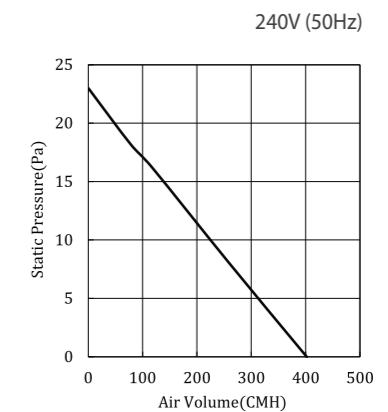

# Performance Data Summary

## Industrial Type Ventilation Fan (Non-AMCA Certified)

### Shutter Series: 40KAQA

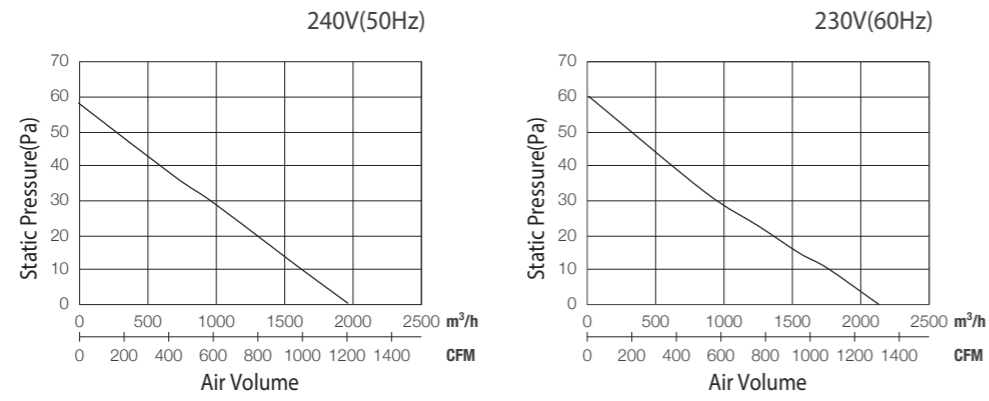
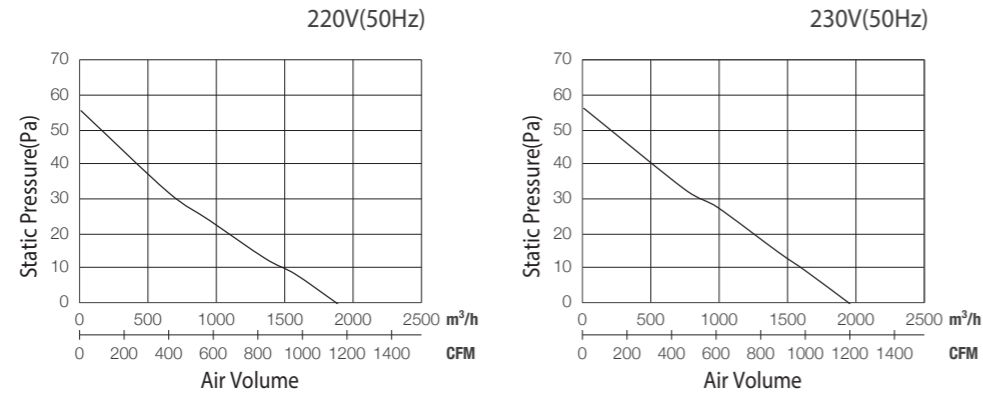

### High Pressure Series: 25GSE

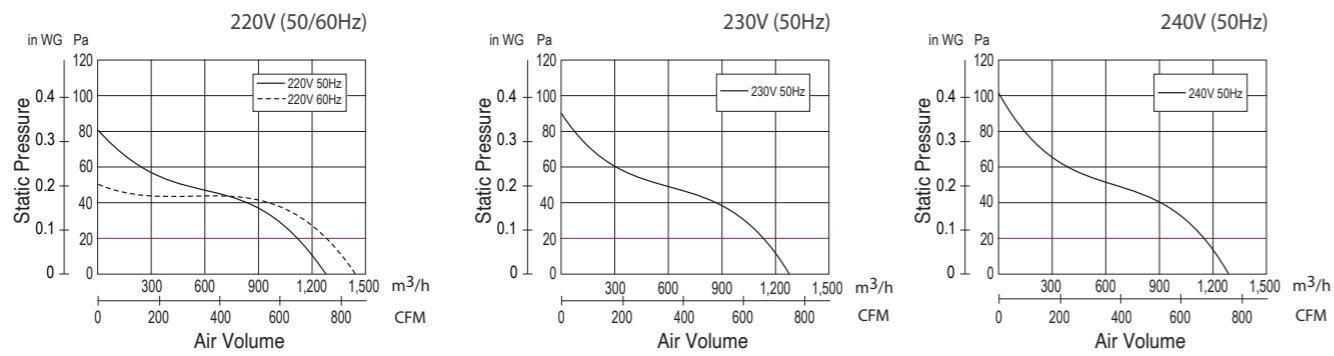

## Industrial Type Ventilation Fan (Non-AMCA Certified)

### High Pressure Series: 30GSE

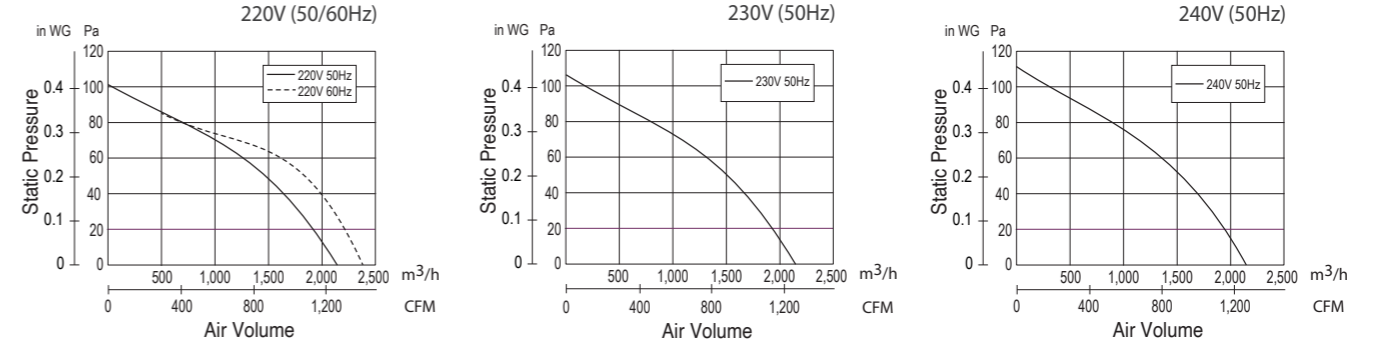

### High Pressure Series: 35GSE

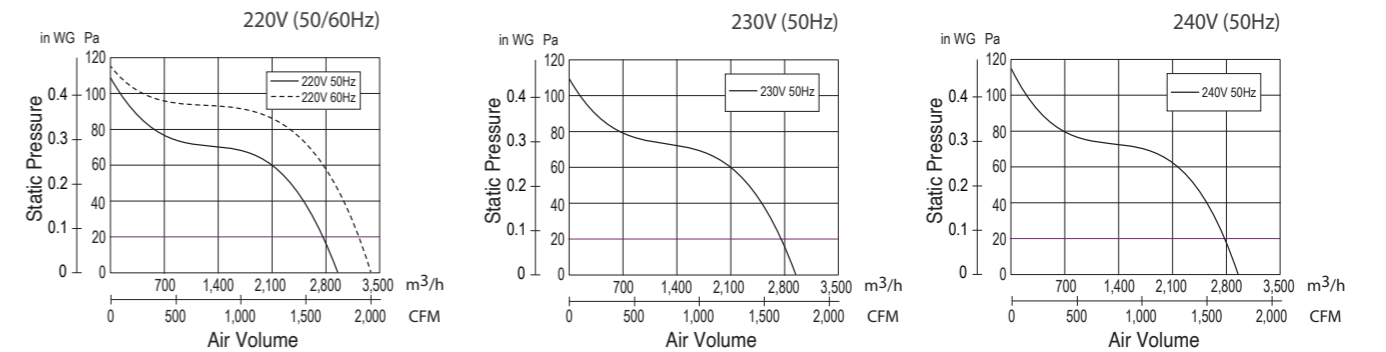

### High Pressure Series: 40GSE

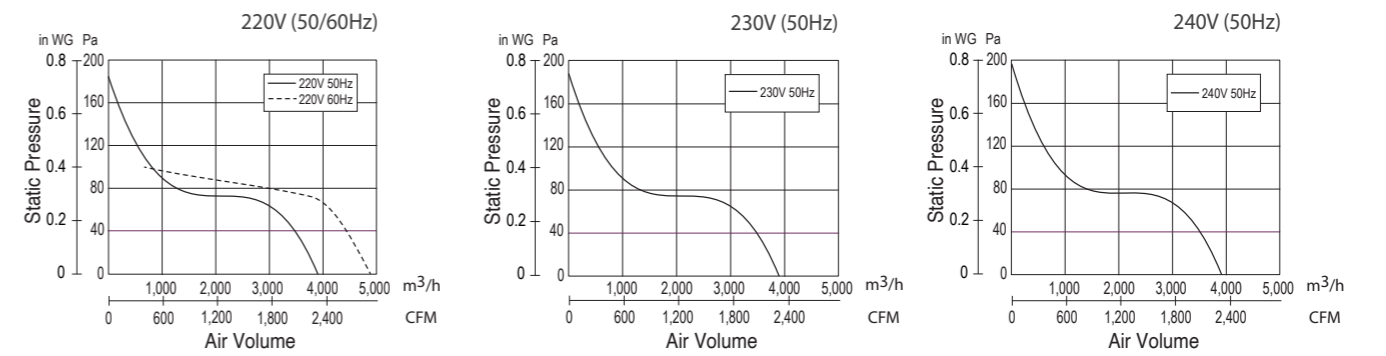

# Performance Data Summary

## Industrial Type Ventilation Fan (Non-AMCA Certified)

### High Pressure Series: 45GSC

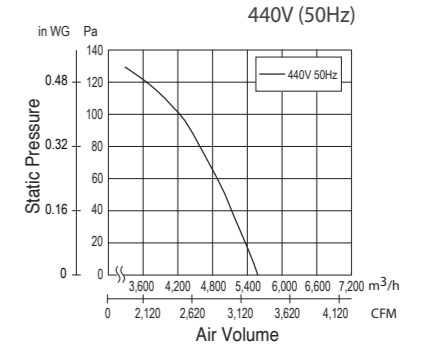
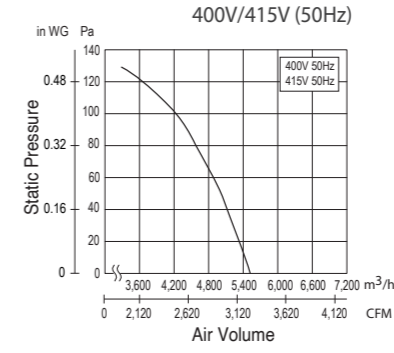
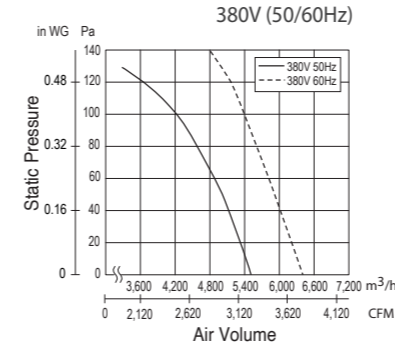
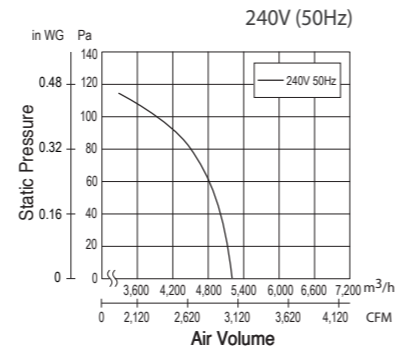
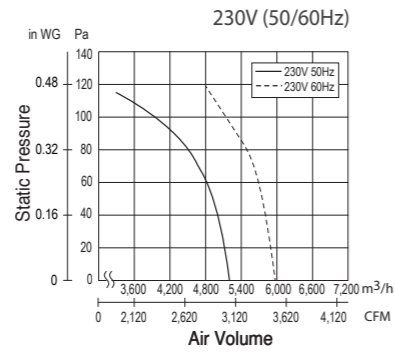
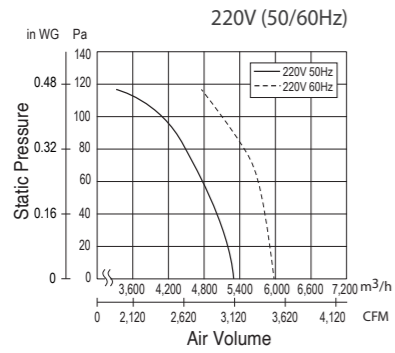

### High Pressure Series: 50GSC

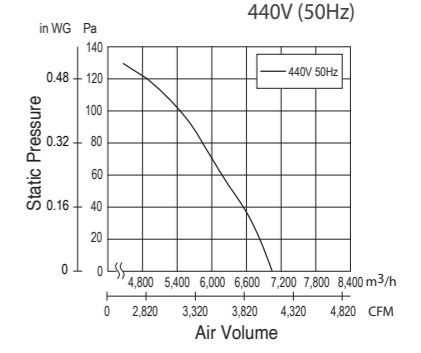
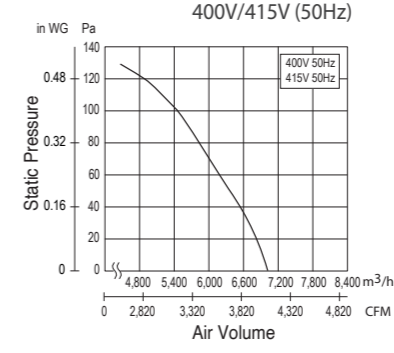
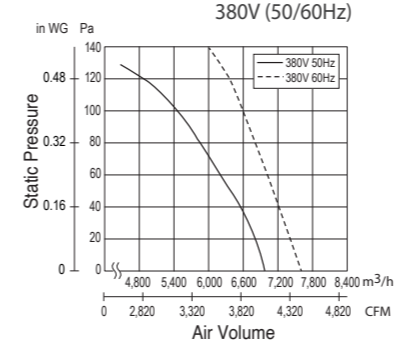
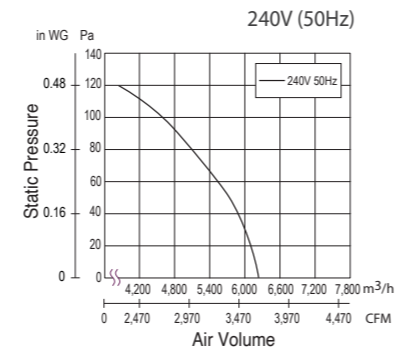
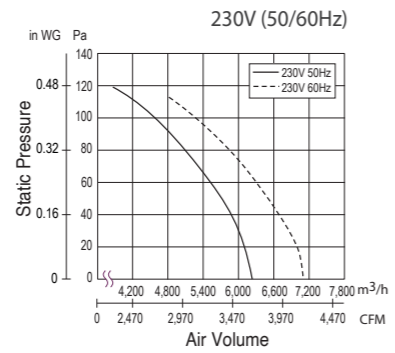
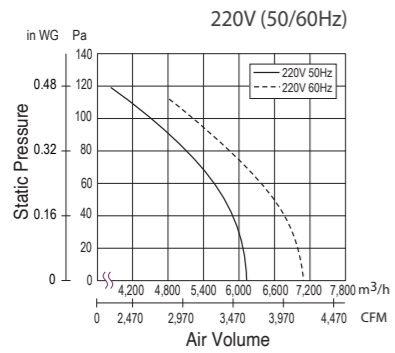

### High Pressure Series: 60GSC

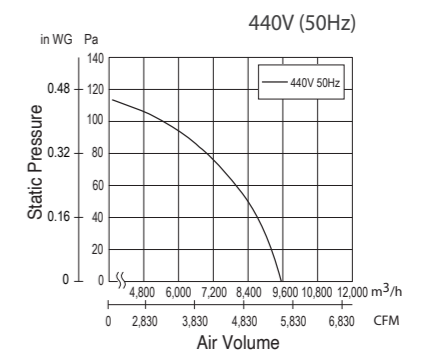
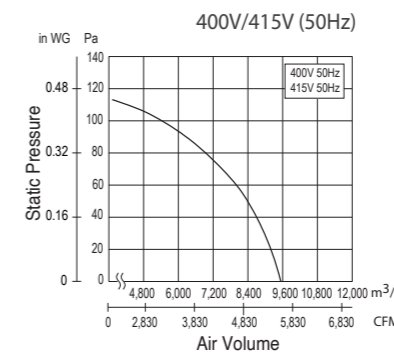
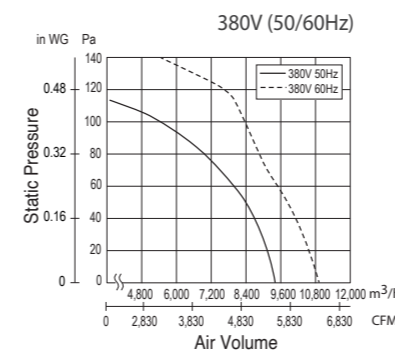
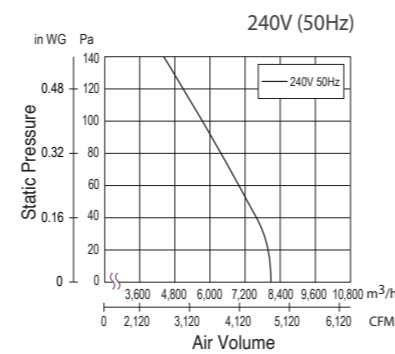
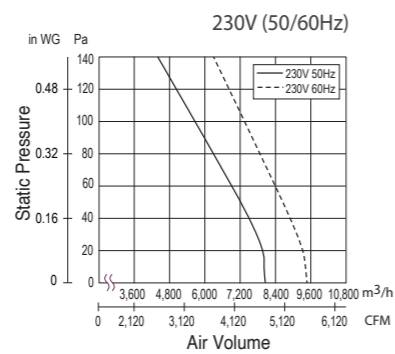
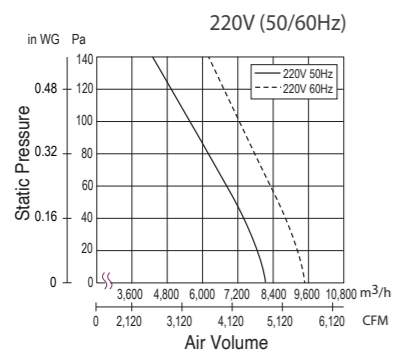

## Industrial Type Ventilation Fan (Non-AMCA Certified)

### High Pressure Series: 45GTC

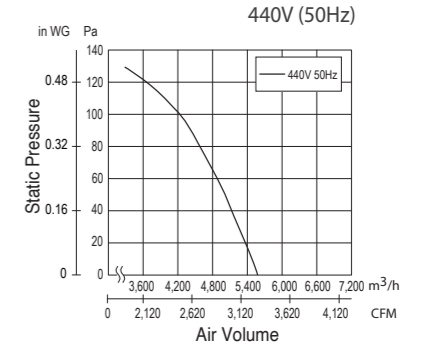
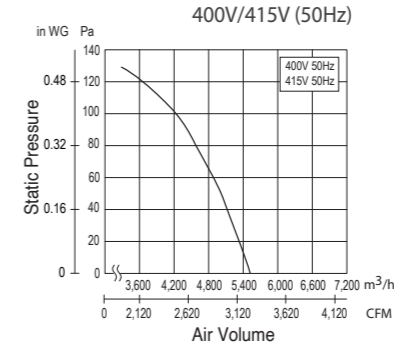
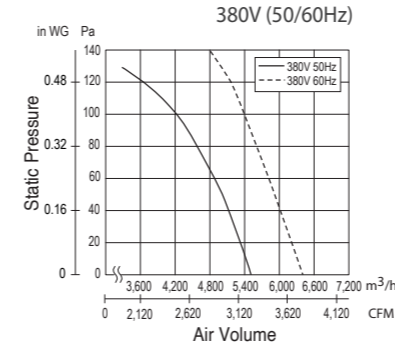

### High Pressure Series: 50GTC

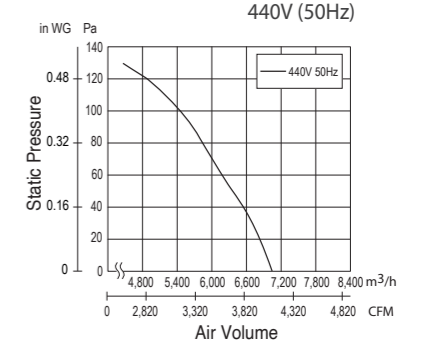
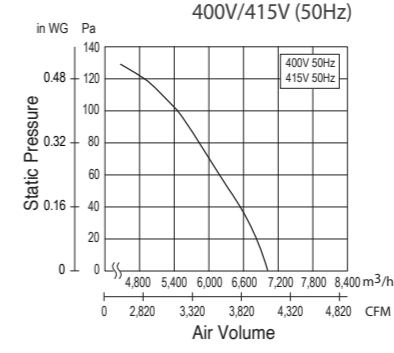
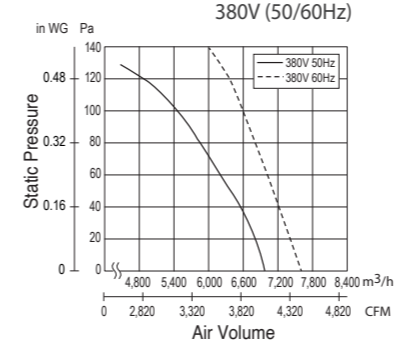

### High Pressure Series: 60GTC

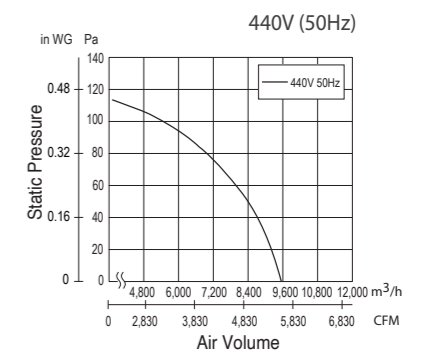
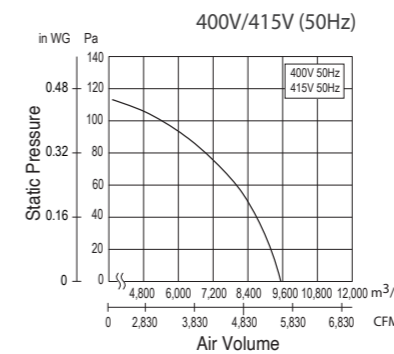
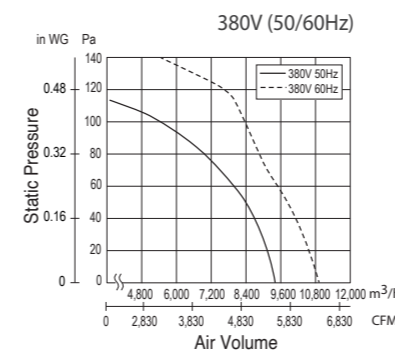

# Performance Data Summary

## Cabinet Fan (In-line Fan) (Non-AMCA Certified)

### Standard Series: 12NSB

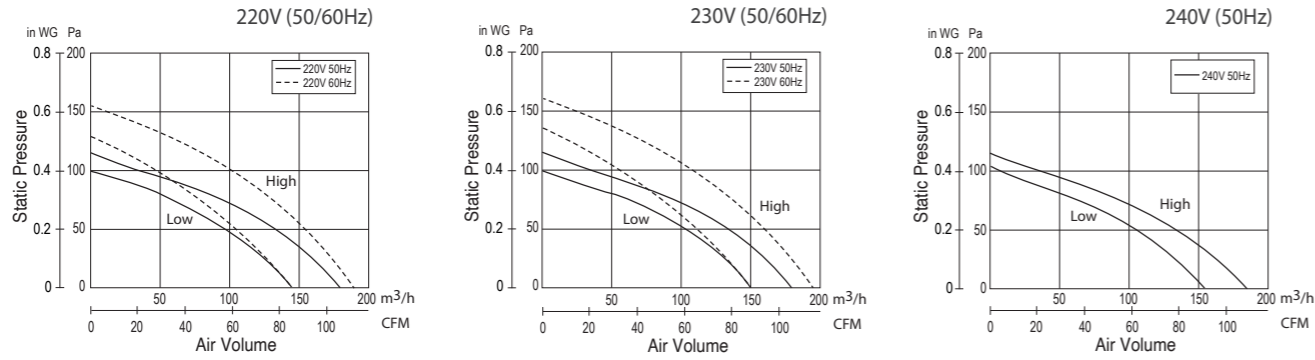

### Standard Series: 15NSB

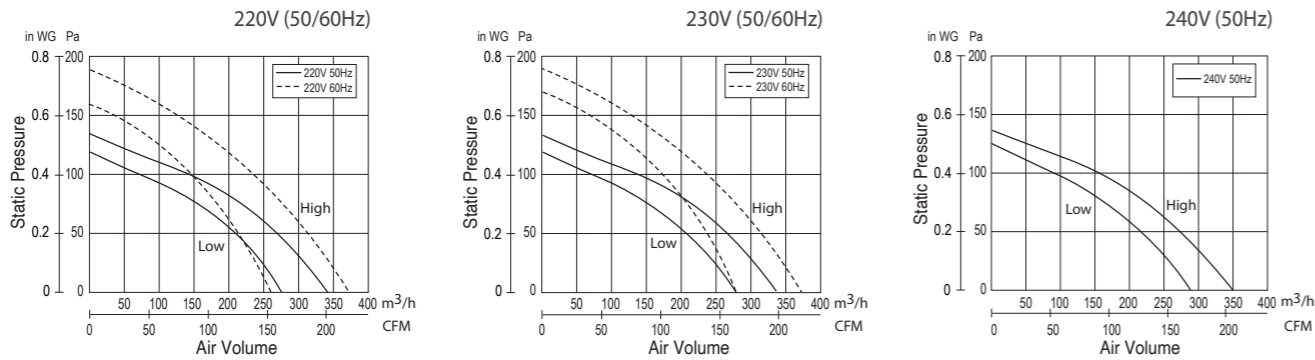

### Standard Series: 18NSB

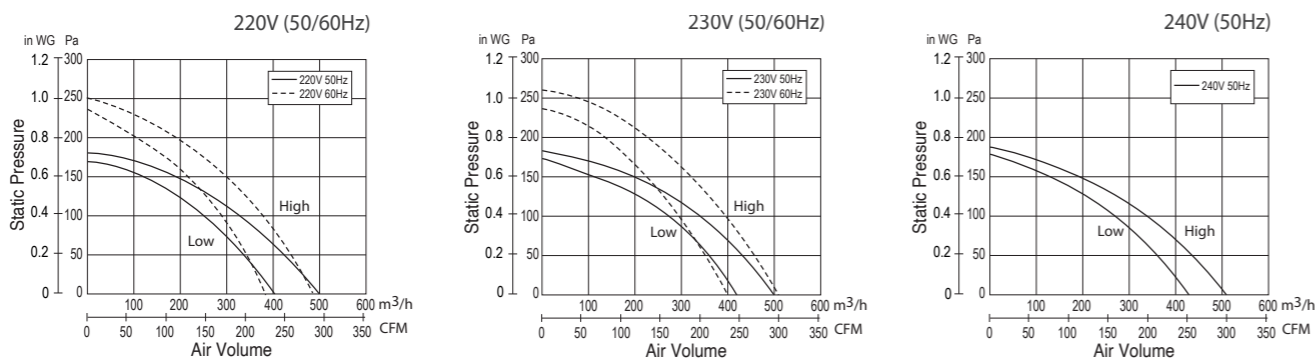

## Cabinet Fan (In-line Fan) (Non-AMCA Certified)

### Standard Series: 18NFB

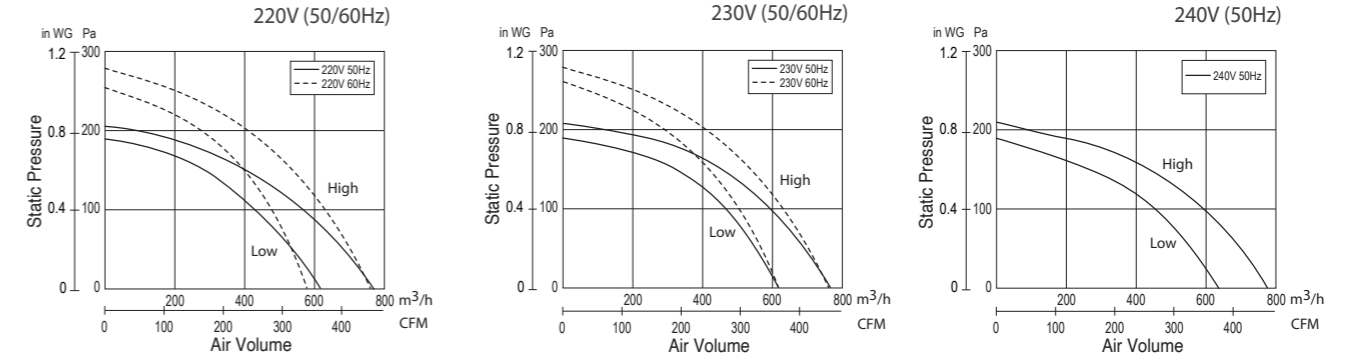

### Standard Series: 20NSB

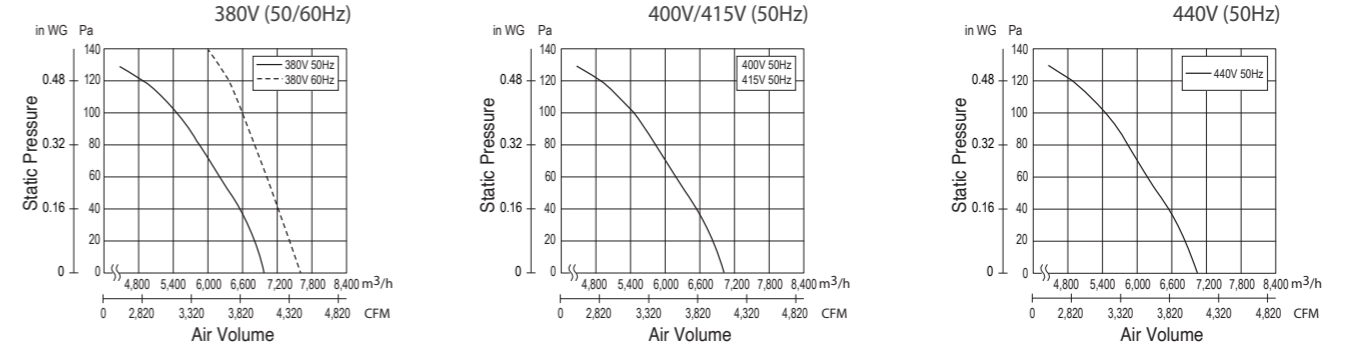

### Standard Series: 23NLB

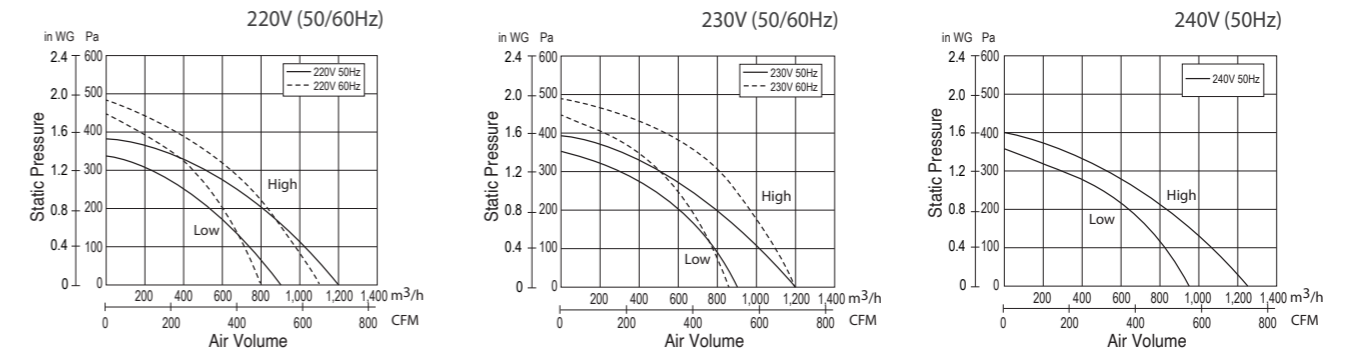

# Performance Data Summary

## Cabinet Fan (In-line Fan) (Non-AMCA Certified)

### Standard Series: 25NSB

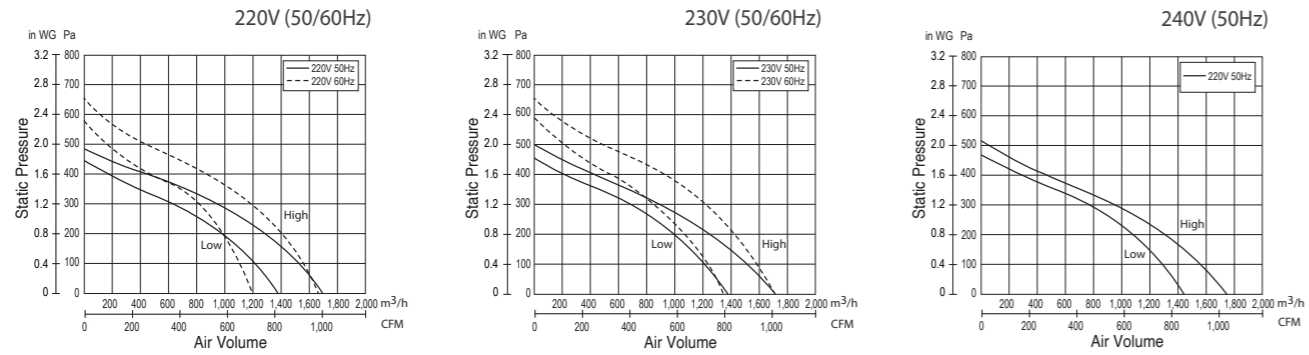

### Standard Series: 25NFB

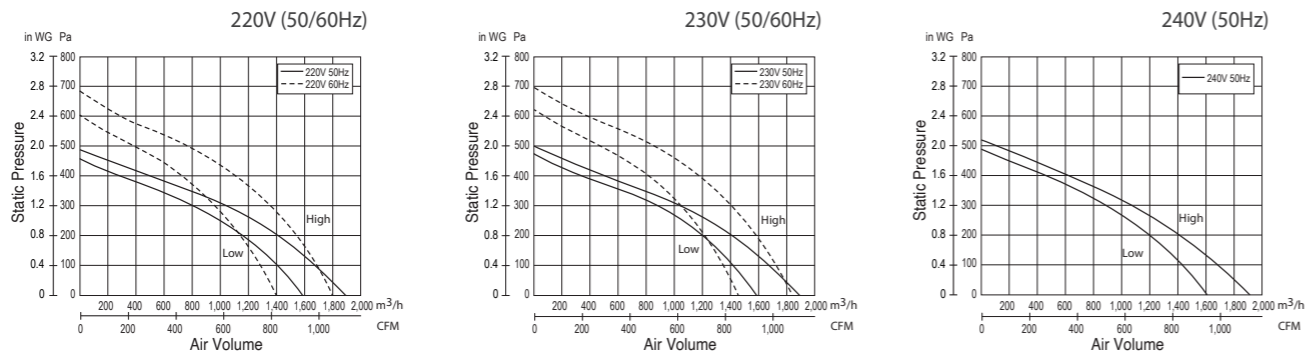

### Three Phase Series: 25SWC

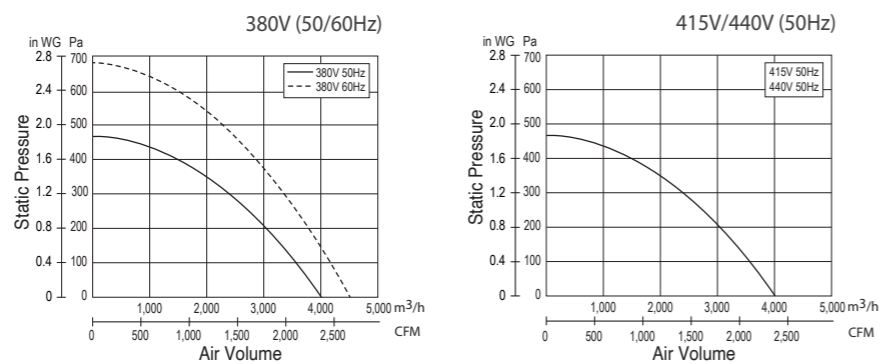

## Cabinet Fan (In-line Fan) (Non-AMCA Certified)

### Three Phase Series: 25SMC

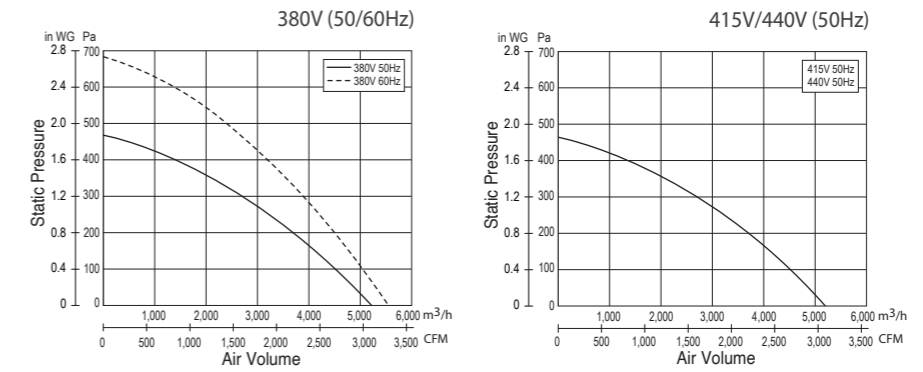

### Three Phase Series: 28NXC

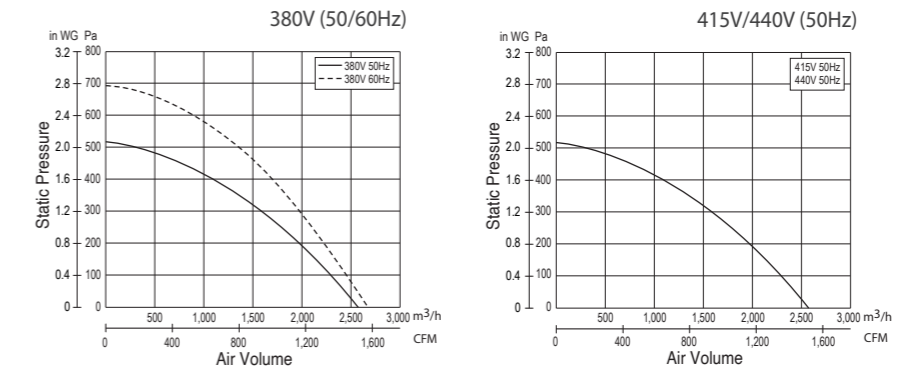

# Performance Data Summary

## Mini Sirocco Fan (Non-AMCA Certified)

### 10CGB

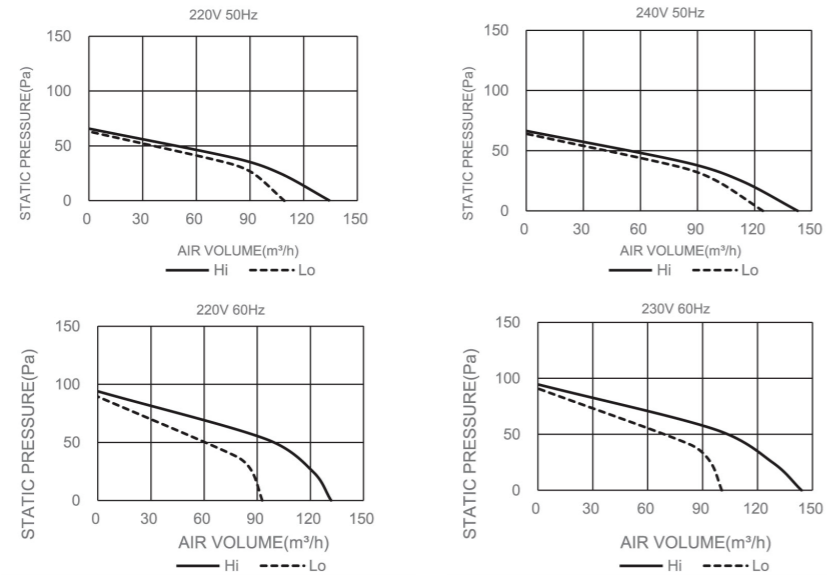

### 12CGB

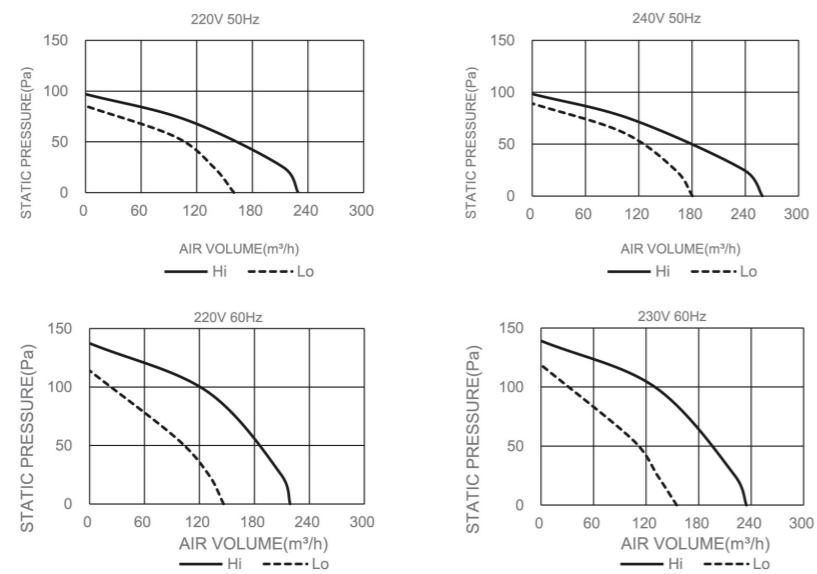

### 17CGB

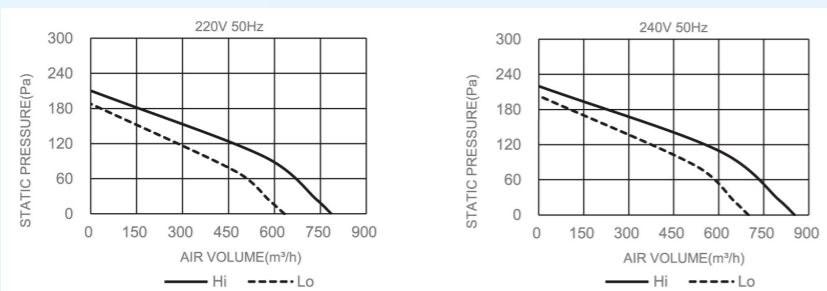

## Mini Sirocco Fan (Non-AMCA Certified)

### 14CGB

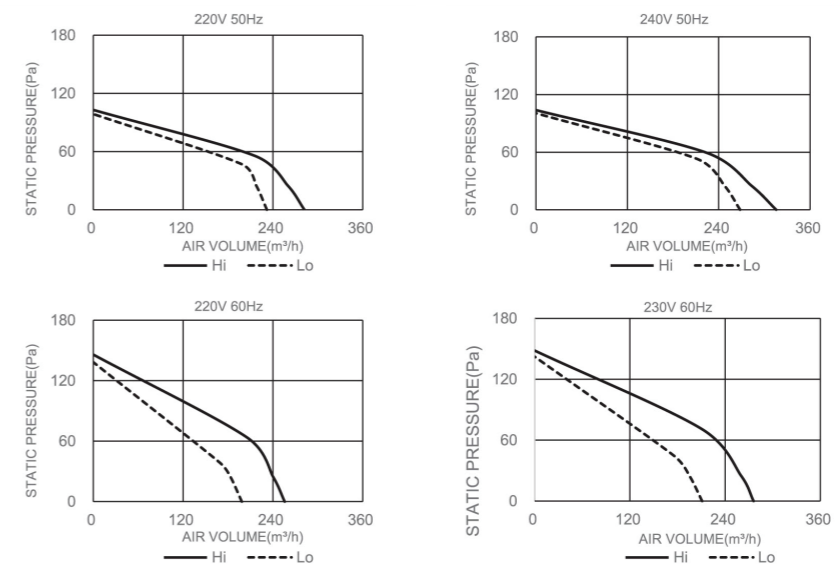

### 16CGB

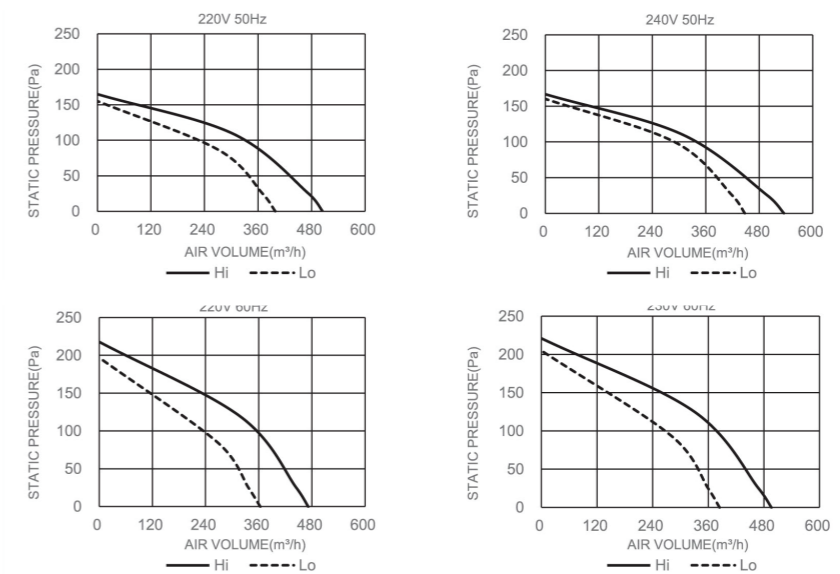

### 17CGB

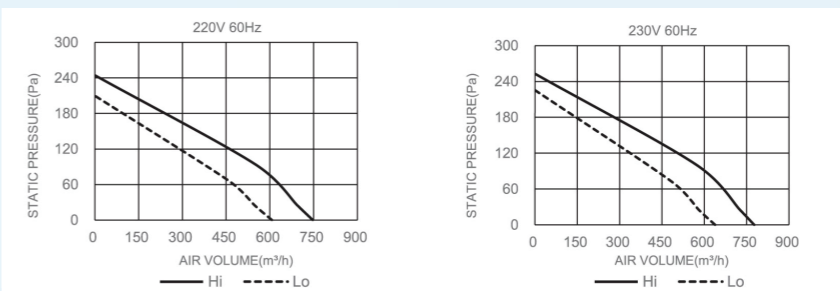

# Performance Data Summary

## Mini Sirocco Fan (Non-AMCA Certified)

### 19CGB

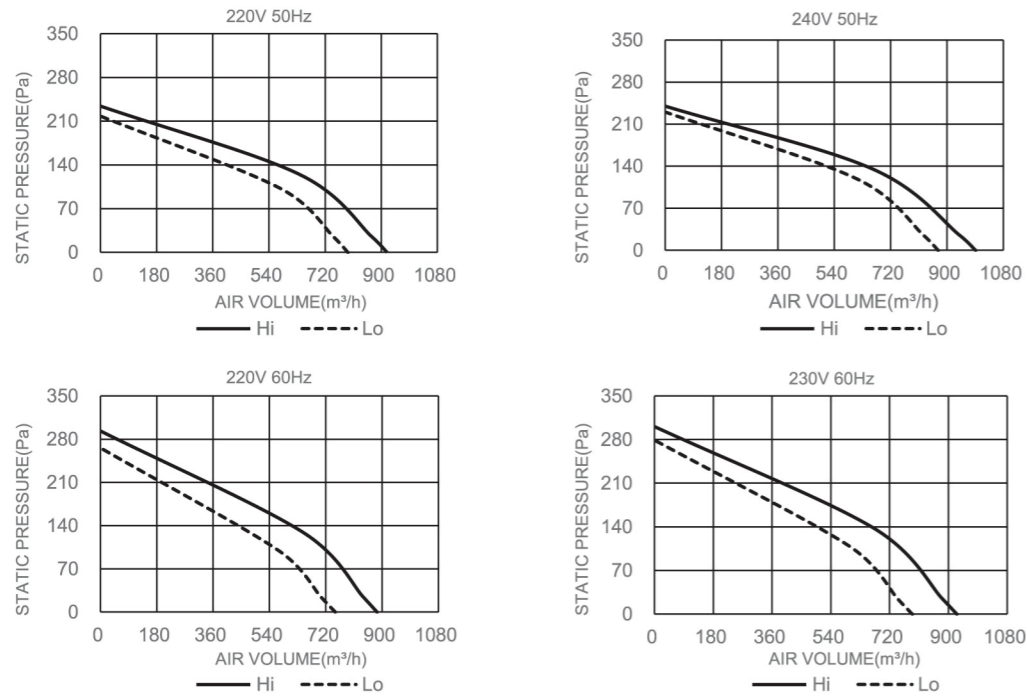

### 21CGB

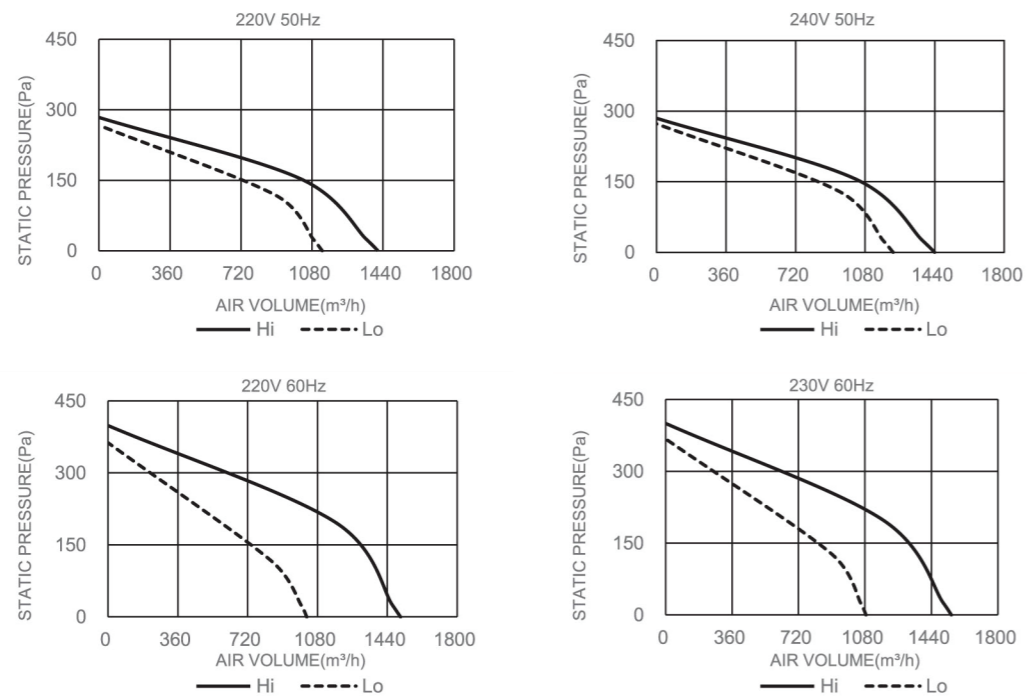

## Energy Recovery Ventilator (Non-AMCA Certified)

### Standard Series: E25DZUA

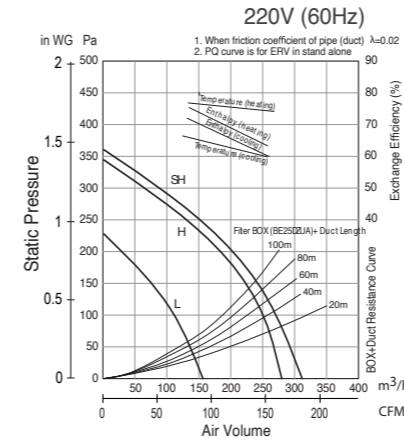

### Standard Series: E35DZUA

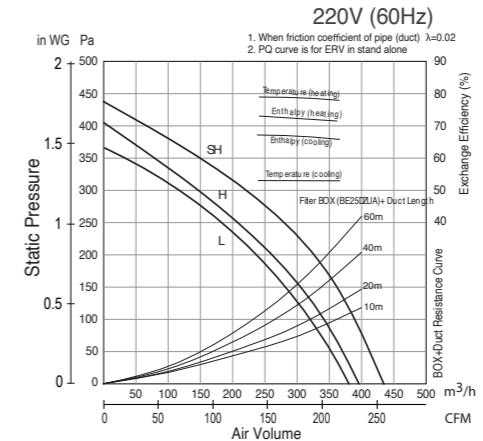

### Standard Series: E50DZUA

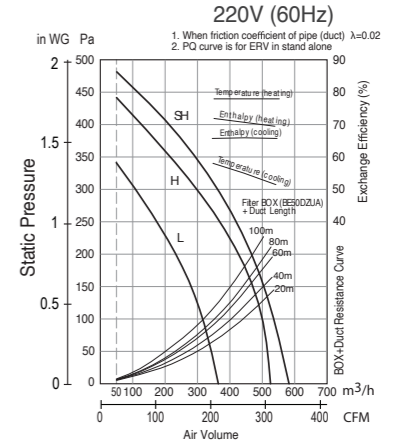

## Thermo Ventilator (Non-AMCA Certified)

### Ceiling Mount Series: 30BUC

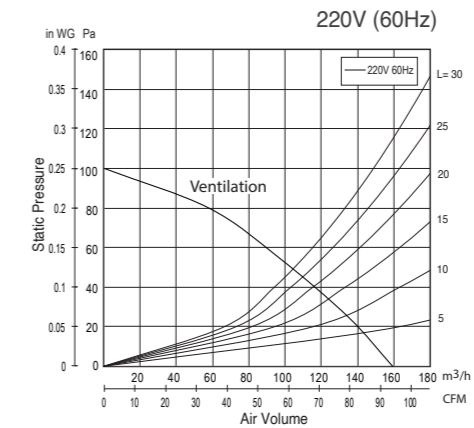

## Range Hood (Non-AMCA Certified)

### Twin Motor Series: 90HQUA

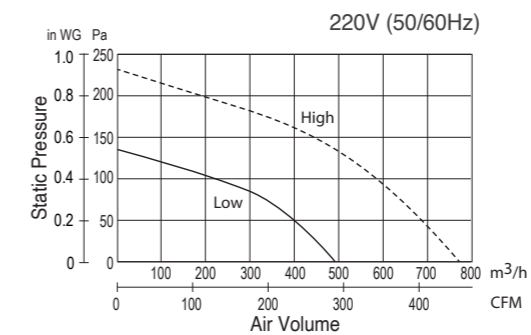

# Reference Project

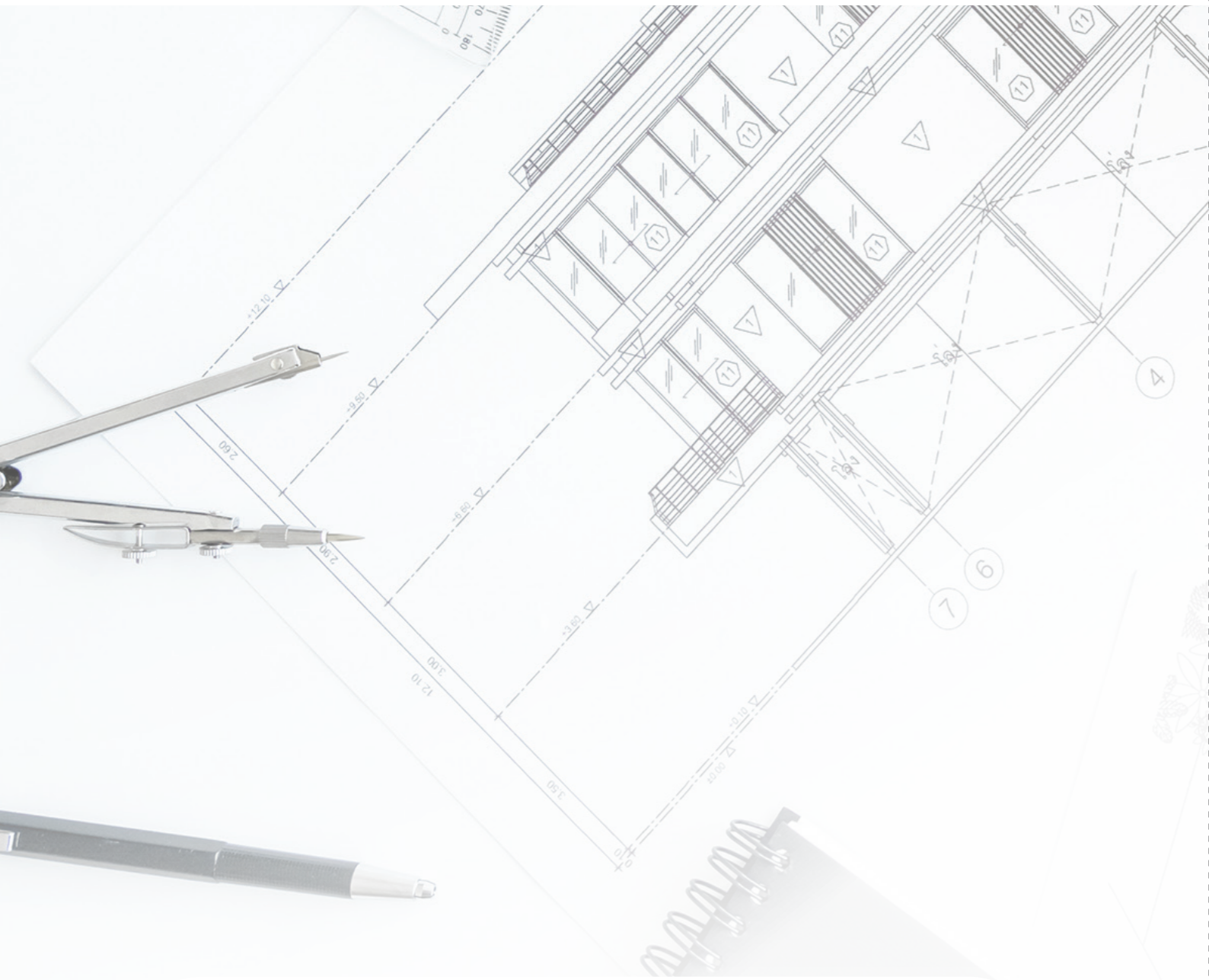

## SAUDI ARABIA

Luxury Villas  
1600 Villa - Sheik Zayed housing program- Phase 1-3  
Window & Wall Mount Ventilation Fan, Sirocco Fan

## SUDAN

Commercial Residential Building  
Energy Recovery Ventilator

## UAE

Residential Villas  
519 villas  
Window Mount Type Ventilation Fan

## UAE

Luxury Villas  
200 villas  
Ducted Ventilation Products

## UAE

Commercial Building  
Window Mount Type Ventilation Fan

## SAUDI ARABIA

Residential Villas  
Local Housing Development  
for Locals  
Ducted Ventilation Products

## QATAR

Residential Villas  
42 Villas  
Window Mount Type Ventilation Fan

## Reference Project

## Installation Method

UAE

Residential Building  
Labor Camps Complex  
Ceiling Fan, Window Mount &  
Industrial Type Ventilation Fan

QATAR

Commercial Residential Building  
Ceiling Fan, Wall Mount Louver  
Type Ventilation Fan

QATAR

Residential Building  
234 Apartments  
Ceiling Mount Type Ventilation Fan

UAE

Residential Villas  
220 Villas  
Window & Wall Mount Type  
Ventilation Fan

SAUDI ARABIA

Net Zero Energy Green House Model  
Cabinet Fan, Wall Mount Louver Type  
Ventilation Fan,  
Energy Recovery Ventilator

- P.159 Ceiling Mount Type Ventilation Fan
- P.161 Wall Mount Type Ventilation Fan
- P.163 Window Mount Type Ventilation Fan
- P.165 Industrial Type Ventilation Fan
- P.166 Cabinet Fan
- P.167 Mini Sirocco Fan
- P.169 Energy Recovery Ventilator
- P.170 Thermo Ventilator
- P.171 Range Hood
- P.172 Hand Dryer
- P.173 Air Curtain
- P.174 Ceiling Fan
- P.176 Orbital Fan
- P.177 Wall Fan

# Ceiling Mount Type Ventilation Fan

## Applicable Model:

24JRB / 24JAB / 17CUH / 24CUH / 24CDH / 24CHH / 24CXH / 27CHH / 32CDH

### 1A Installation with anchor bolts

1. Secure 1 set of suspension bracket (optional accessory) with screws.

The screw length should not exceed 8mm.

\*2 sets of accessories are required for 32CDH and 32CHH

23mm  
Adjustable range

Suspension bracket position

25mm  
Adjustable range

Model No.	A	B	C
17CUH	206	89	103
24CUH / 24CDH / 24CHH / 24CXH	266	131	112
24JRB / 24JAB	286	130	97
27CHH	296	160	158.5
32CDH	346	200	158.5

Unit : mm

2. Mount the fan body enclosure on the anchor bolts (M8-M10, not supplied).

### 1B Installation with wooden joist

1. First remove the hexagon screw attaching the adapter assembly to the fan body.

2. Build a wooden frame horizontally from the keel. Note that the distance between the top of the fan body and the ceiling should be at least 20mm.

\*Ceiling joist must be subjected to static load more than 5 times of the product weight.

Model No.	F	B
17CUH	177	25-30
24CUH / 24CDH / 24CHH / 24CXH	240	25-30
24JRB / 24JAB	240	30-40
27CHH	270	25-30
32CDH	320	25-30

Unit : mm

3. Attach the adapter assembly to the wooden frame as shown in the figure.

4. Insert the fan body in the wooden frame and connect it to the adapter assembly.

5. Firmly secure the fan body with four tapping screws and a hexagon screw.

# Ceiling Mount Type Ventilation Fan

### 2 Power Cord Connection

1. Connect the power cord to the power supply line according to the wiring diagram and the local electrical wiring rules of fixed wiring.

Make sure all connections are fastened firmly after wiring is finished.

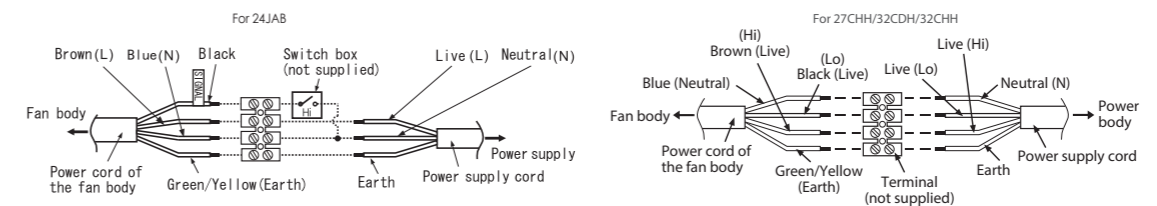

### 3 Duct Connection and Ceiling Plate Installation

1. Insert the duct into the adapter assembly, and tighten it with adhesive tape (not supplied). (Suspend the duct from the ceiling to prevent any external force onto the fan body.)

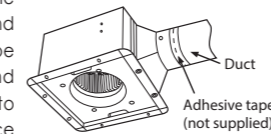

Slope the duct downward and guide it through the wall to the outside. Be sure to prevent rainwater from falling in the duct from its outlet. (The minimum size of the hole opening on the wall is: Ø116mm for 17/24 model, Ø168mm for 27/32 model)

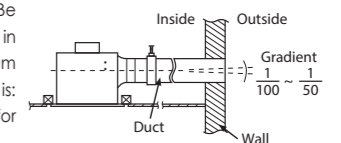

2. Install the ceiling plate. Note that the gap between the flange and the ceiling plate should be 2 to 3 mm.

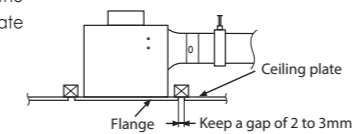

3. Install the pipe hood or vent cap (optional accessories) on the outer wall.

Model No.	Pipe Hood	Vent Cap
24JRB / 24JAB / 17CUH / 24CUH / 24CDH / 24CHH / 24CXH	MCX100K	VCX100K
27CHH / 32CDH	MCX150K	VCX150K

### 4 Louver Installation

1. For 24JRB only  
Check the sensor lead wire is fixed in the wire hook. Keep the wire away from the air intake and fan blade.

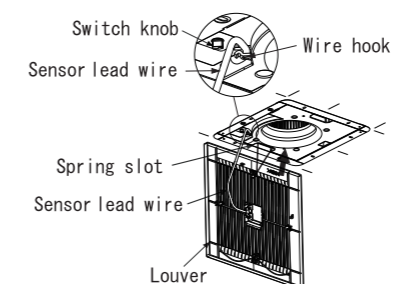

2. Insert the mounting spring into the slots and mount the louver to the fan body. (Please wear gloves during installation.)

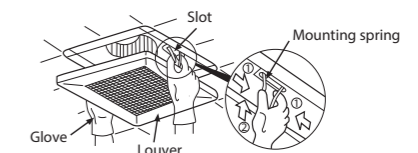

# Wall Mount Type Ventilation Fan

Applicable Model:  
AU model / AL model

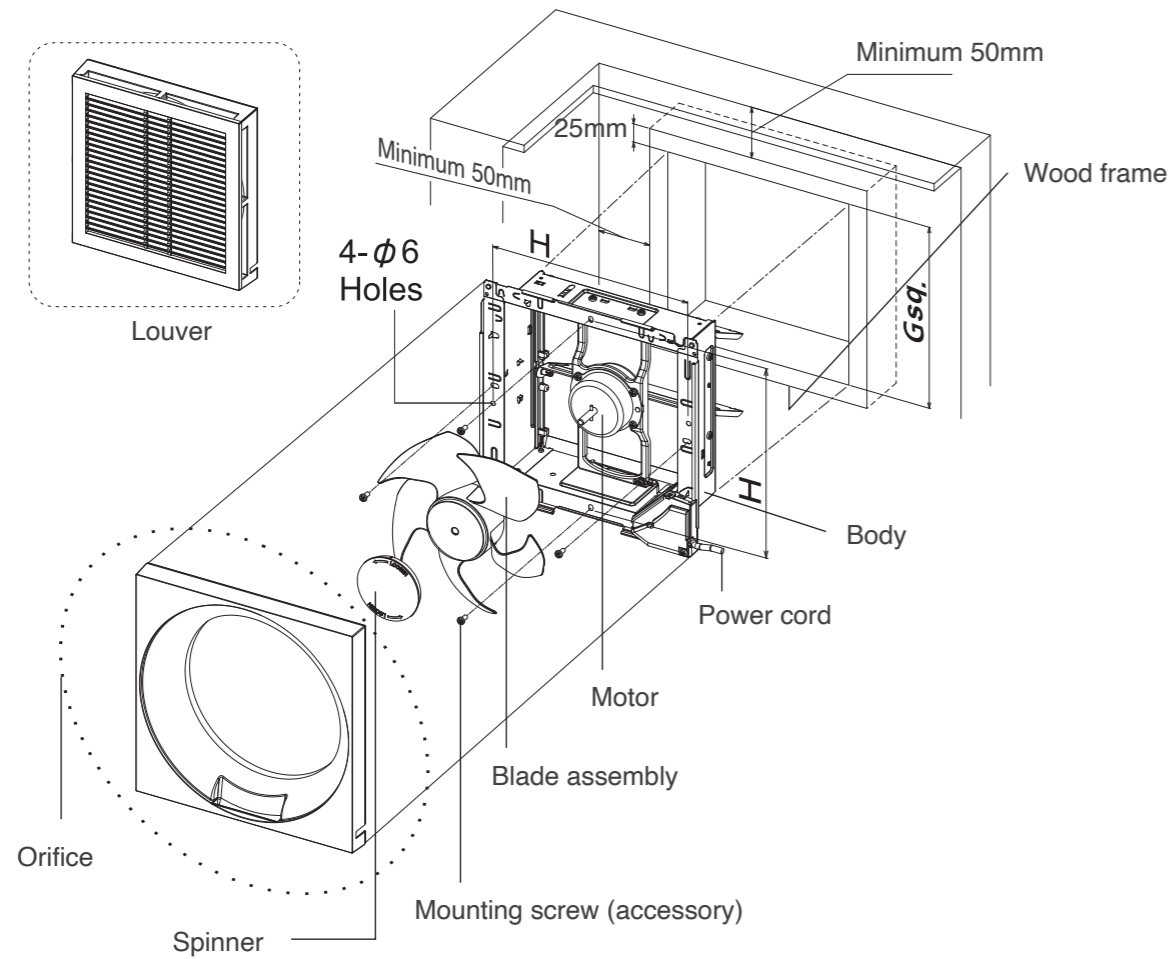

- Connect the power cord to the power supply line according to the wiring diagram and the local electrical wiring rules of fixed wiring.
- Make sure all connections are fastened firmly after wiring is finished.
- It is required to use terminal (not supplied) that complies IEC 60998.
- The all connections should be accommodated in a suitable compartment.

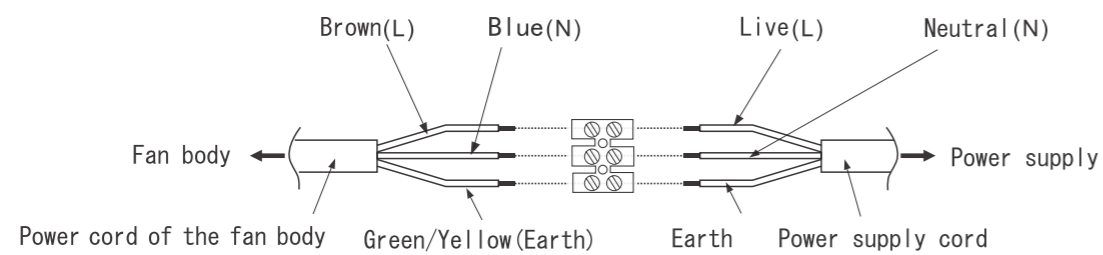

# Wall Mount Type Ventilation Fan

Applicable Model:  
10EGKB/15EGKB

1. Make appropriate hole in the wall for ducting.

Position of hole. Bathroom side

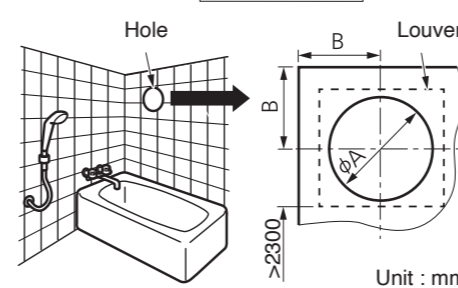

Model	$\phi A$	B	Wall thickness
10EGKB	130~140	>125	100~150
15EGKB	175~185	>150	

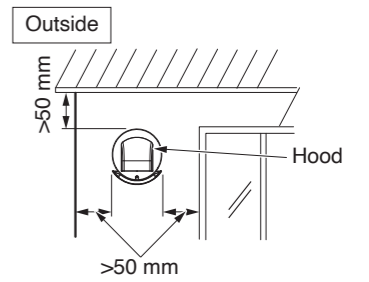
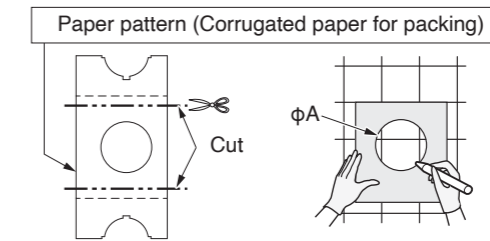

Note : It is noted that the wall does not collapse when making hole.  
Do not install on the bumpy or rotten wall.

2. Drill holes for plug bolt.

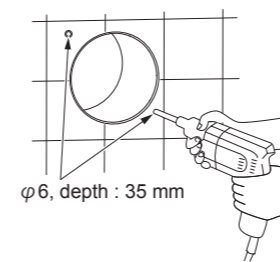

3. Insert the duct 1 to the wall using two screws and plug bolt.

Plug bolt (Accessories)

Note : Use accessory plug bolt and screw.

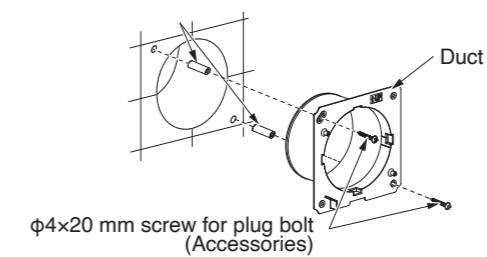

4. Insert the fan body to the duct 1.

Note : Make sure that use screw to fix the fan body. It may cause drop the fan body.

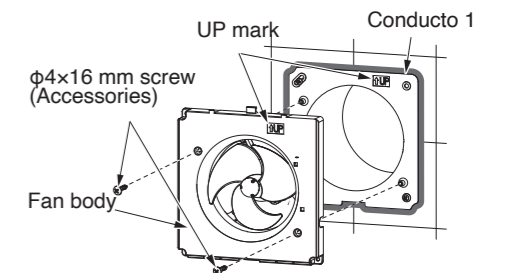

5. Install the louver

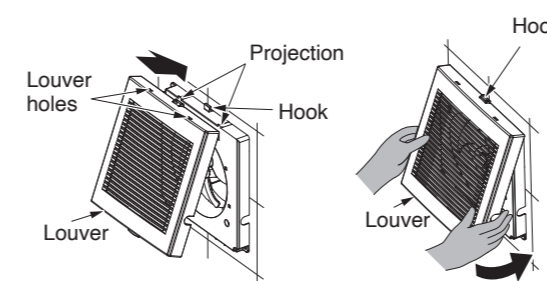

6. Hood installation (From outside wall)

① Put these notches together.

② Insert the duct 2 from outside wall.

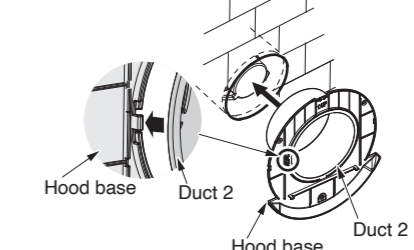

Duct 2

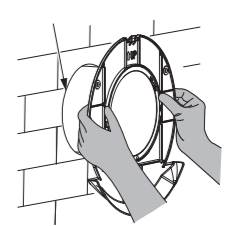

Note : Fit the duct 2 into the hood base when it come off.

7. Drill three holes for plug bolts.

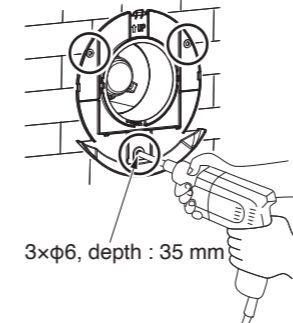

8. Hang and fix hood.

① Hang the hood into the hook. ② Fit the hood into the hood base.

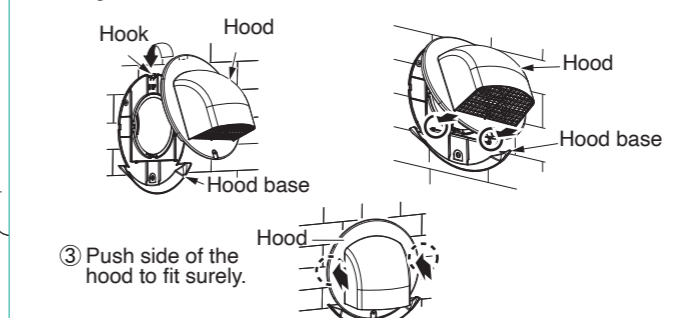

9. Insert the hood to the wall seal with caulking around the hood.

Note : Make sure that use accessory screw to fix the hood. It may cause drop the hood.

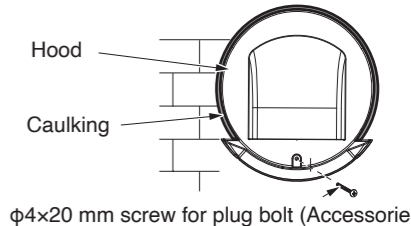

# Window Mount Type Ventilation Fan

## Applicable Model: 15WHCT/20WHCT

1. Make an installation hole on the window glass according to the dimensions shown in the table.  
(Applicable to single-glass or double-glass, and the single block thickness of double-glass must be not less than 3mm.)

Model No.	A	B	C
15WHCT	186-188	390 Min.	100 Min.
20WHCT	247-250	450 Min.	100 Min.

Unit : mm

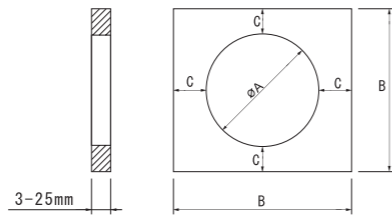

2. Remove the screw of louver and retain it, then pull the louver out of the lower-right corner.

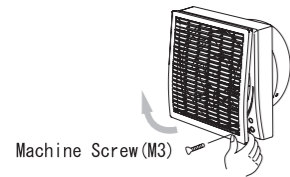

Louver can be pulled out only from the lower-right corner or it may be damaged.



3. Before installation, please ensure every installation plate is at the position as shown below.

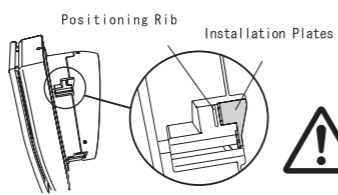

As shown in the diagram, the installation plates must be positioned in the slot between the frame and the hood. Its front edge should not exceed the positioning rib, or installation may fail.

4. Keep the "UP" mark on the orifice on the top position. Insert the ventilation fan body into the installation hole completely. Be sure to keep the back of the body closed to the glass evenly, then twist each installation screw clockwise until the installation plates slightly compress the glass.

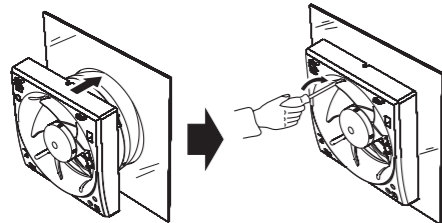

Please do not use the electric screwdriver which may damage the glass.

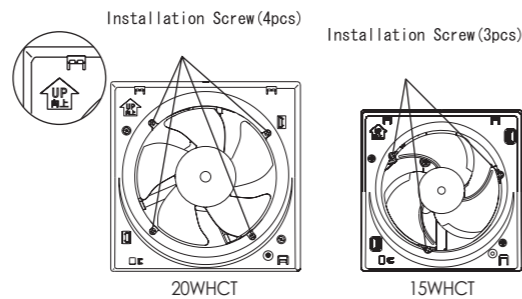

5. Rotate the body to adjust its horizontal and vertical direction. Then tighten each installation screw completely.

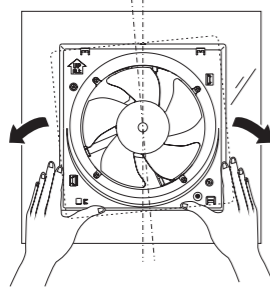

To ensure the installation strength, please make sure the tighten torque must be in the range of 90cN-m to 180cN-m. If the tighten torque is not large enough, it may result in rain water ingress through the gap; if the tighten torque is too large, it may damage the glass.

6. Hang the louver on the hook of orifice, rotate downward and insert it into the orifice. Fix the louver with the screw which was removed at installation step 2.

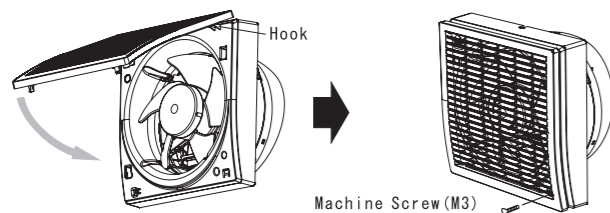

Must use the above specified screw to fix. Otherwise it may damage the product or lead to installation failure.



# Window Mount Type Ventilation Fan

## Applicable Model: 15WUD/20WUD/15WAA/20WAA

1. Make an installation hole on the window glass.

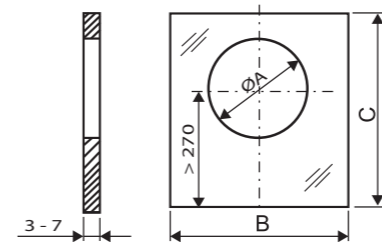

Unit : mm

Model No.	A	B	C
15WUD	186-188	≥250	≥400
20WUD	247-250	≥300	≥420
15WAA	186-188	≥250	≥250
20WAA	247-250	≥300	≥300

2. Set the plastic gasket on the hole that the seam is at upper half (either left or right side). Seal the gap between the glass and gasket with silicon sealant to ensure airtightness.

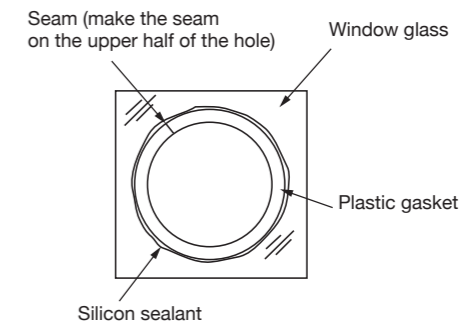

3. Loosen the orifice screws (2 pcs) and remove the orifice.

15WUD / 20WUD

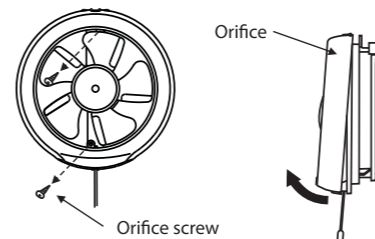

15WAA

20WAA

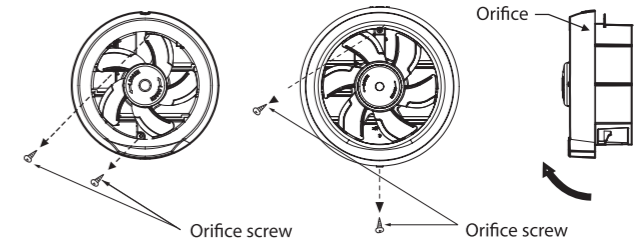

4. While installing the fan, align the fan to top of the hole of window glass and push the bottom of the fan into the hole. Then push the fan downward and tighten the safety screw afterward.

15WUD / 20WUD

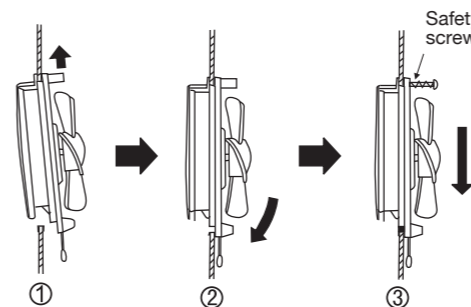

15WAA / 20WAA

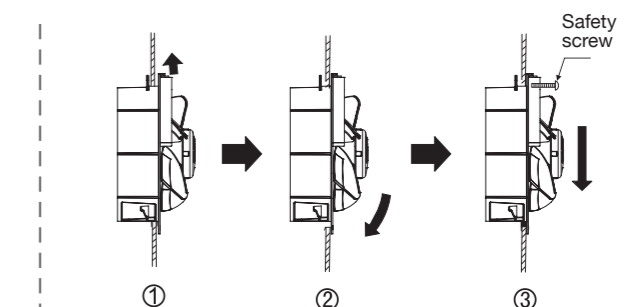

5. Set the orifice and fix with the orifice screws (2 pcs)

15WUD / 20WUD

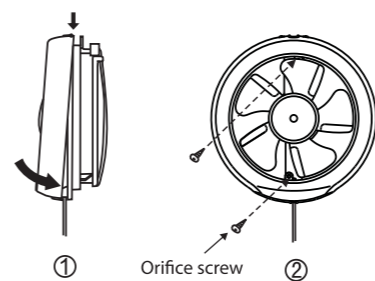

15WAA / 20WAA

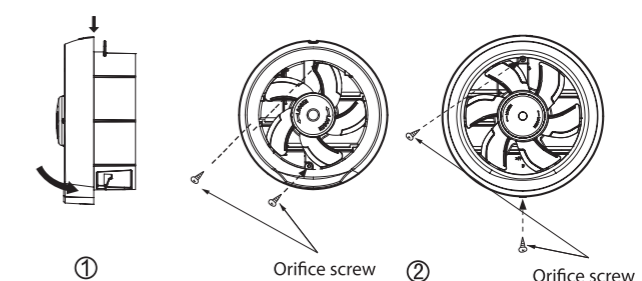

# Industrial Type Ventilation Fan

Applicable Model:  
High Pressure Series

## Installation on concrete wall

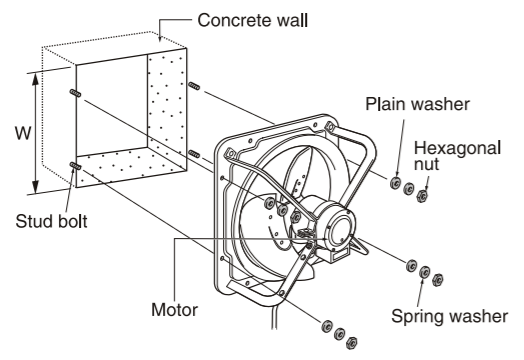

## Installation on wooden frame

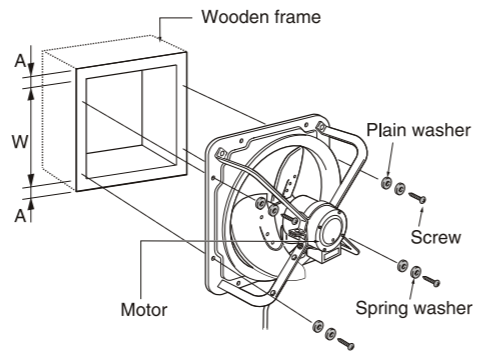

## Setting of Reverse Airflow

- For 25GSE, 30GSE and 35GSE
- 1) Loosen the blade setscrew to remove the blade
  - 2) Set the wiring according to wiring diagrams in operation instruction
  - 3) Mount the blade in reverse position and fix with the blade set screw

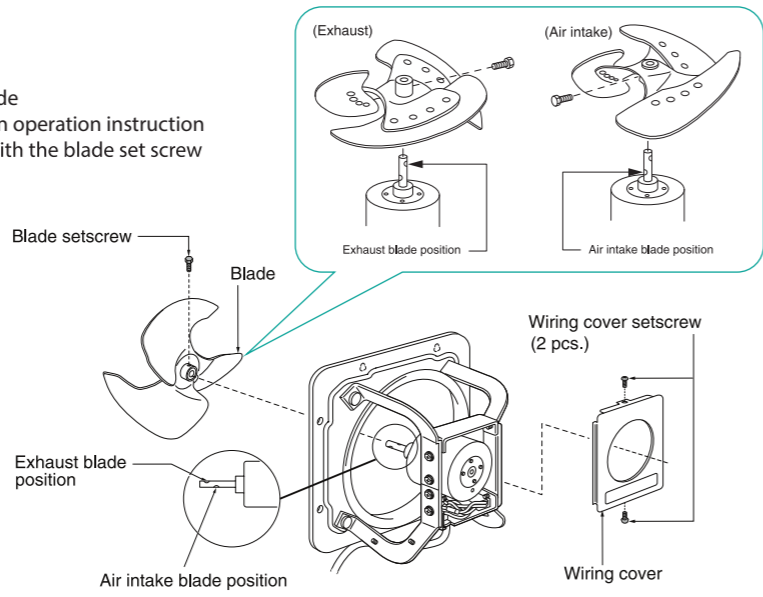

- For 40GSE, 45GSC, 50GSC, 60GSC, 45GTC, 50GTC & 60GTC
- 1) Loosen the blade setscrew <sup>(\*)1</sup> or snap pin / hexagonal nut <sup>(\*)2</sup> to remove the blade
  - 2) Set the wiring according to wiring diagrams in operation instruction
  - 3) Mount the blade in reverse position and fix with the blade setscrew <sup>(\*)1</sup> or snap pin / hexagonal nut <sup>(\*)2</sup>

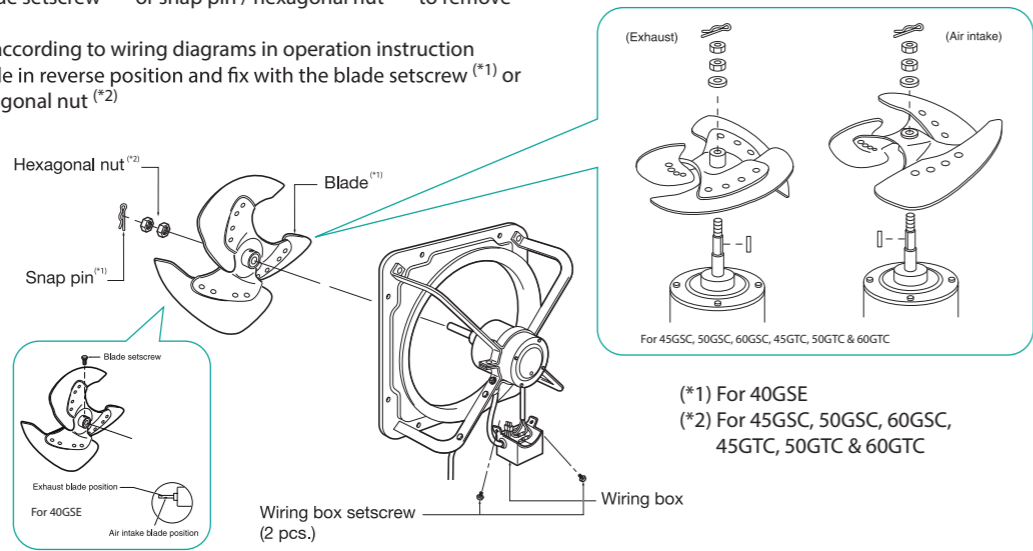

(\*)1 For 40GSE  
(\*)2 For 45GSC, 50GSC, 60GSC, 45GTC, 50GTC & 60GTC

\* Air volume of reverse airflow (intake) would vary subject to different models

# Low Noise Type Cabinet Fan (In-line Fan)

Applicable Model:  
12NSB/15NSB/18NSB/18NFB/20NSB/23NLB/25NSB/25NFB

To hang the fan be sure to attach firmly with hanger bolts, washers and nuts. (Which should be M8-M10 and be supplied by the customer)

Vibration cushion rubber set (supplied by the customer) can be used if in special condition for vibration requirement and it must support the weight of the product.

The structure of the ceiling and the suspending set for hanging the product must support more than 5 times weight of the product.

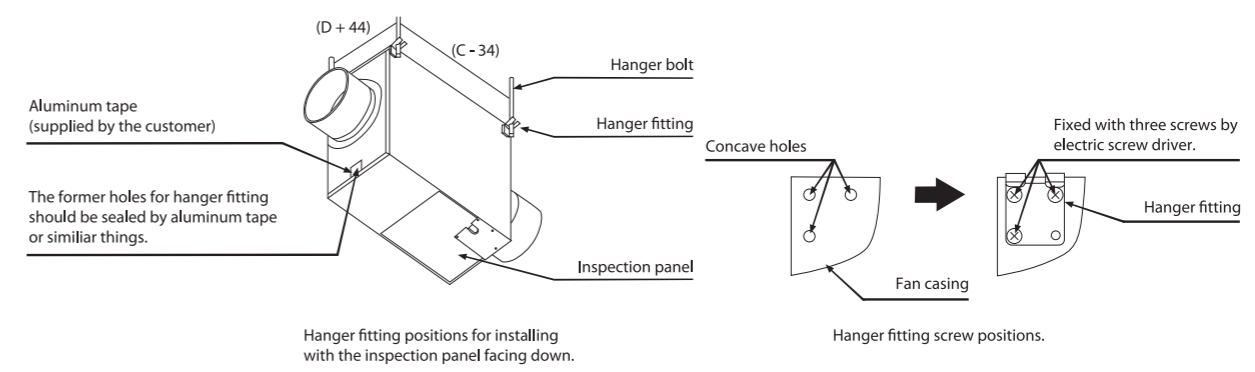
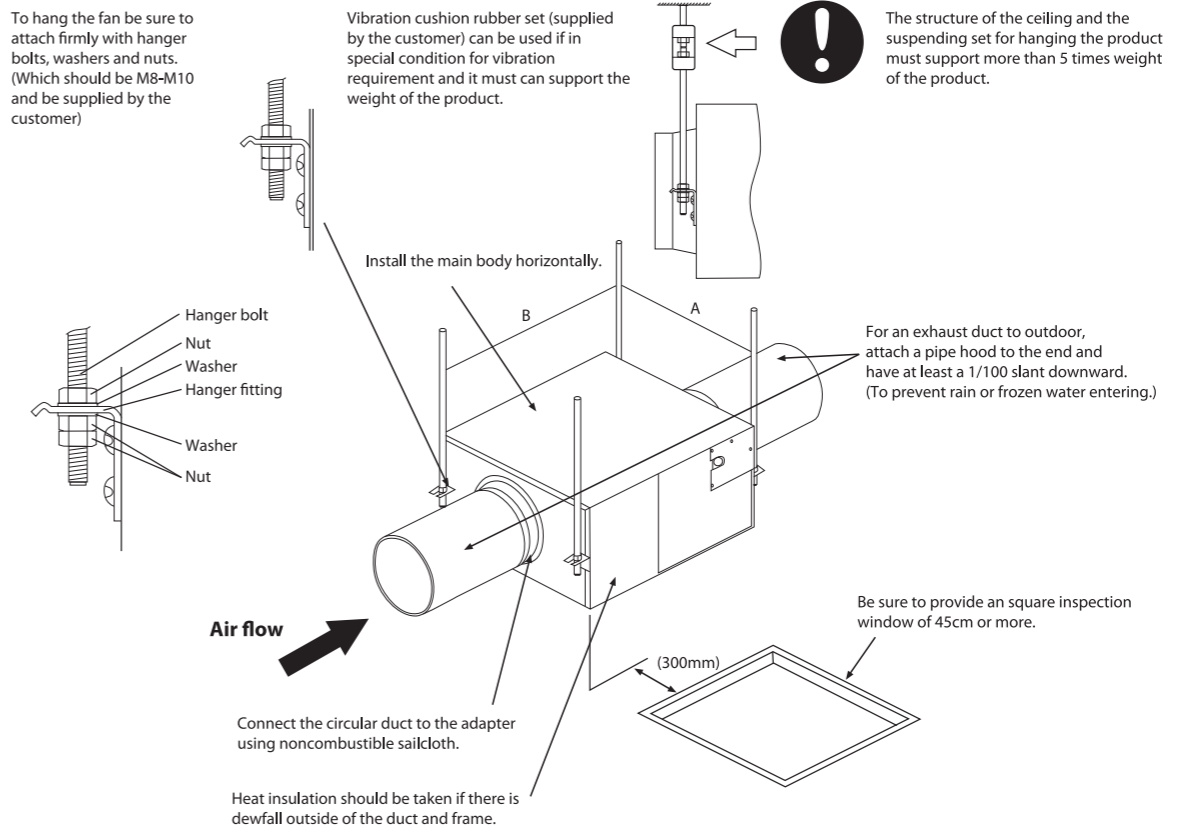

Note: To install the fan with the inspection panel facing down, remove the attached four hanger fittings and re-attach them in the holes on the top and bottom surfaces (Use the screws you just removed). The former holes for installing the hanger fitting need be sealed.

Model No.	A	B	C	D
12NSB	250	335	291	184
15NSB	250	346	302	206
18NSB	276	382	338	232
18NFB	336	441	397	254
20NSB	376	485	441	272
23NLB	424	513	469	298
25NSB	450	549	505	334
25NFB	450	549	505	334

Unit : mm

# Low Noise Type Cabinet Fan (In-line Fan)

Applicable Model:  
25SWC/25SMC

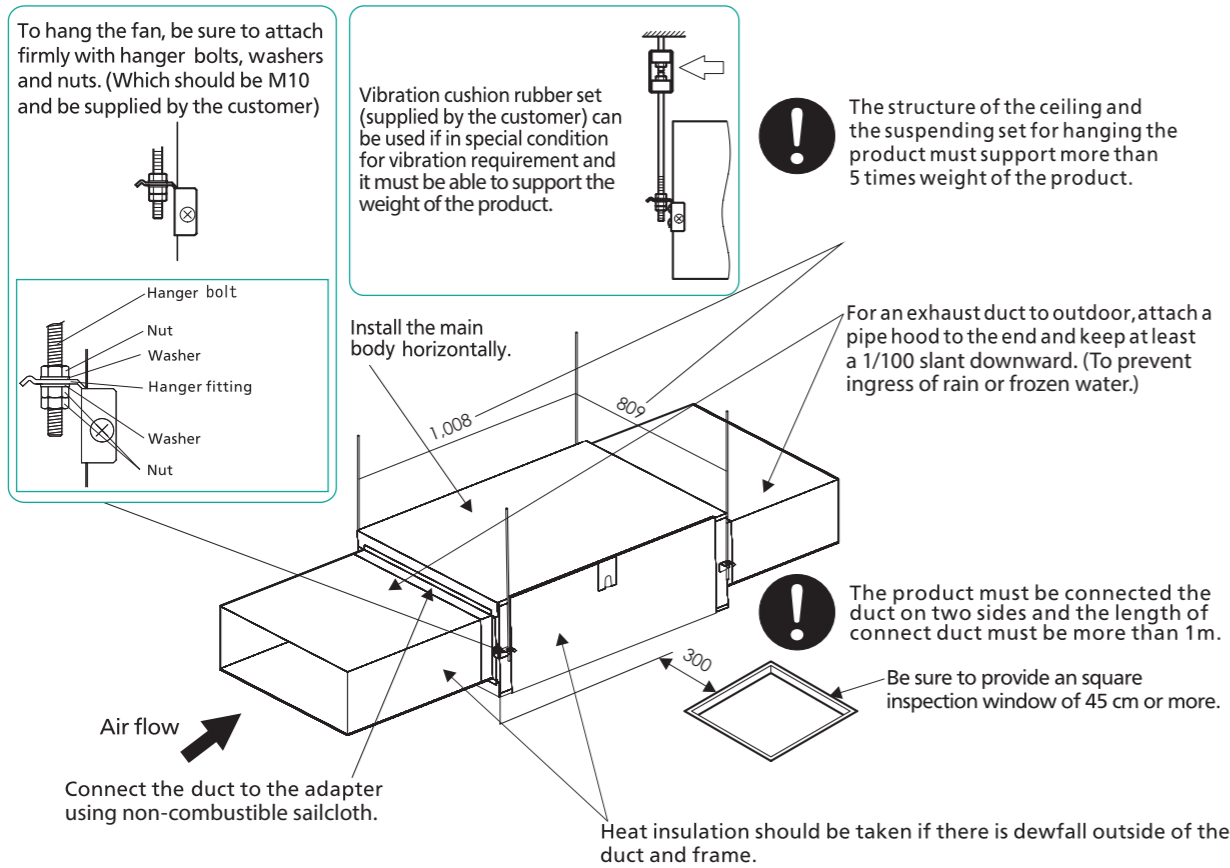

## Wiring Connection

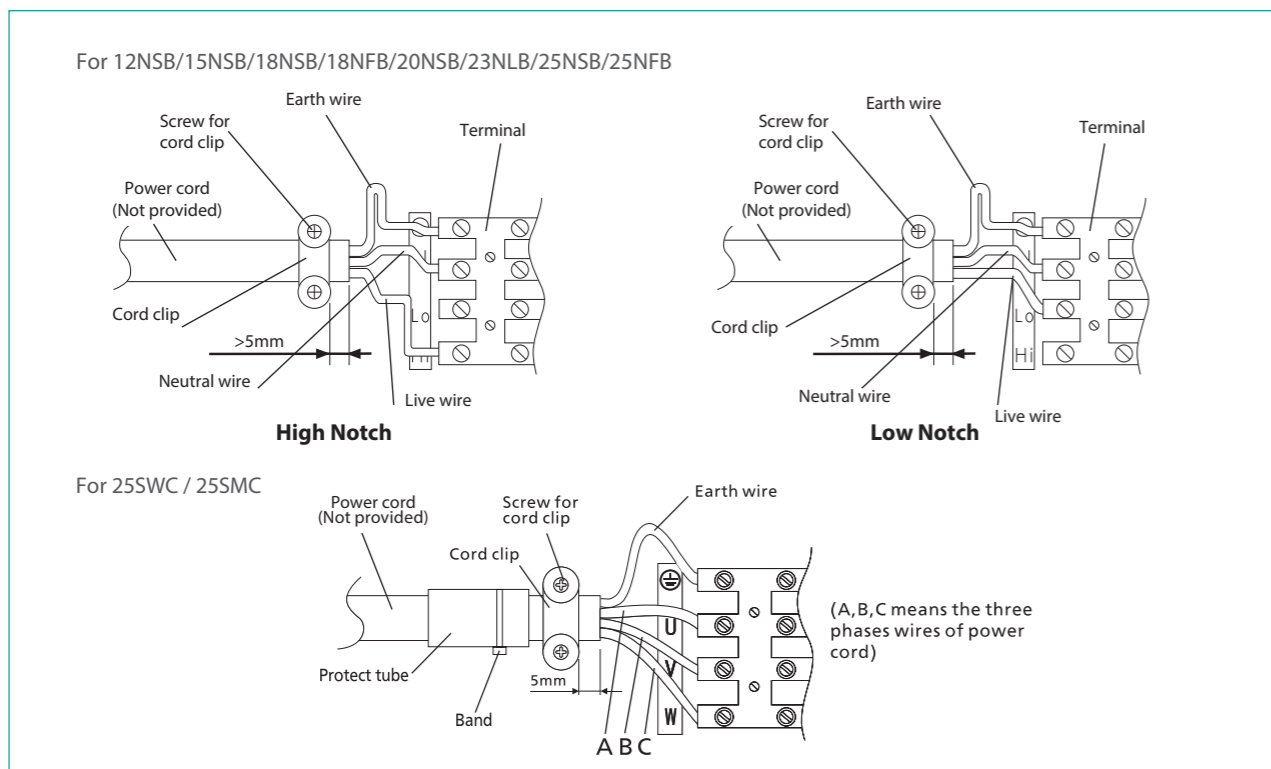

# Mini Sirocco Fan

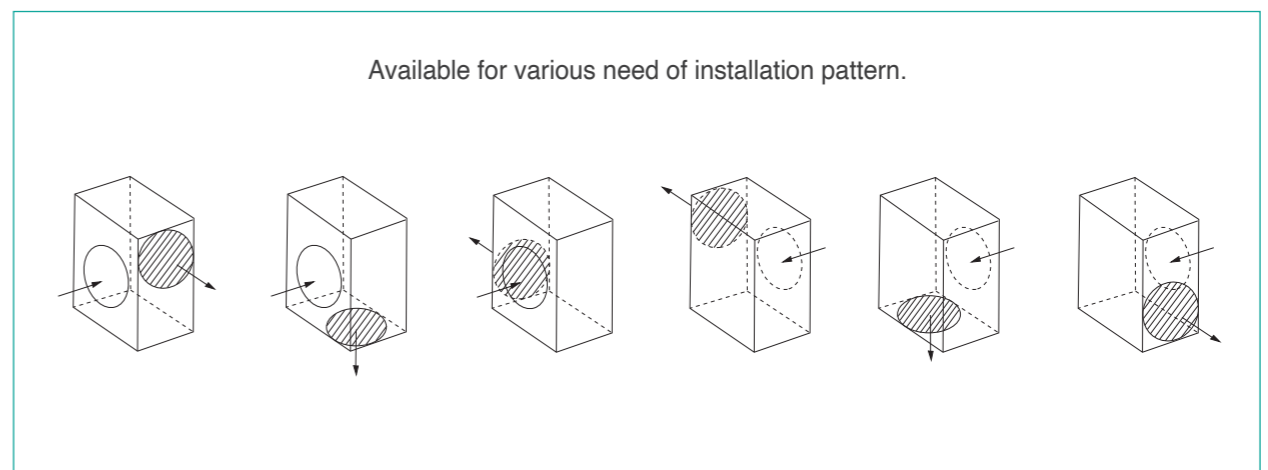
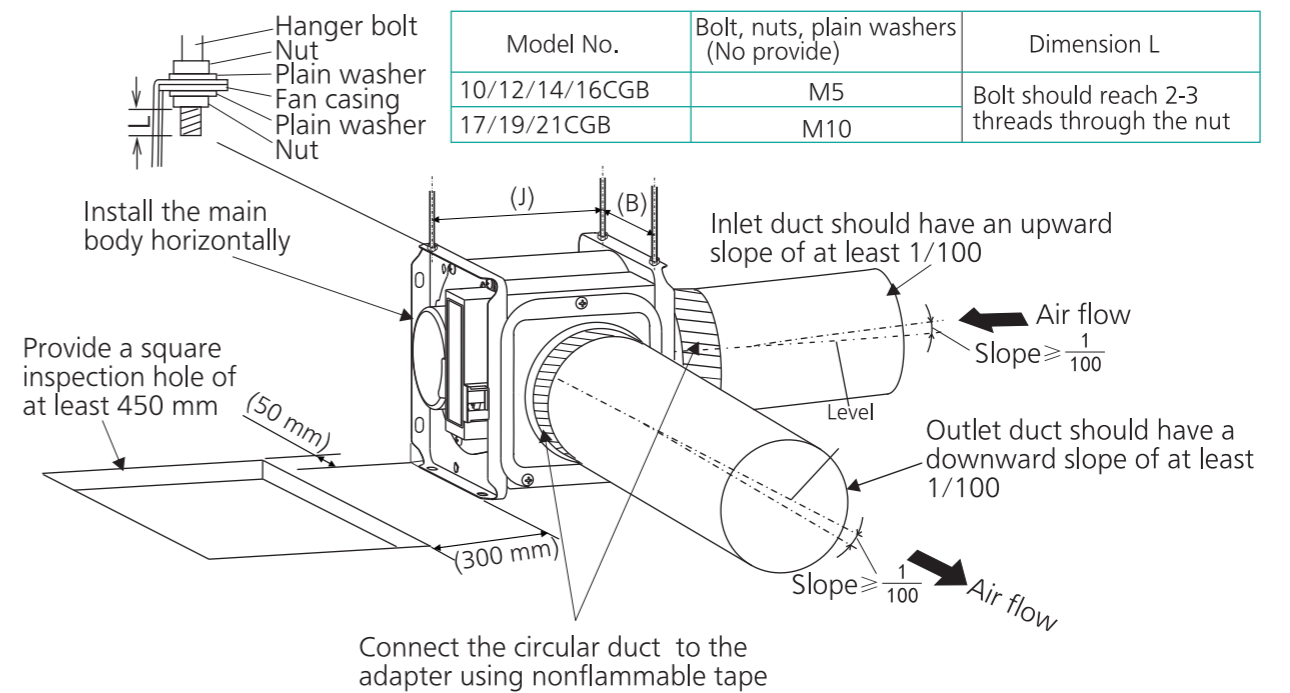
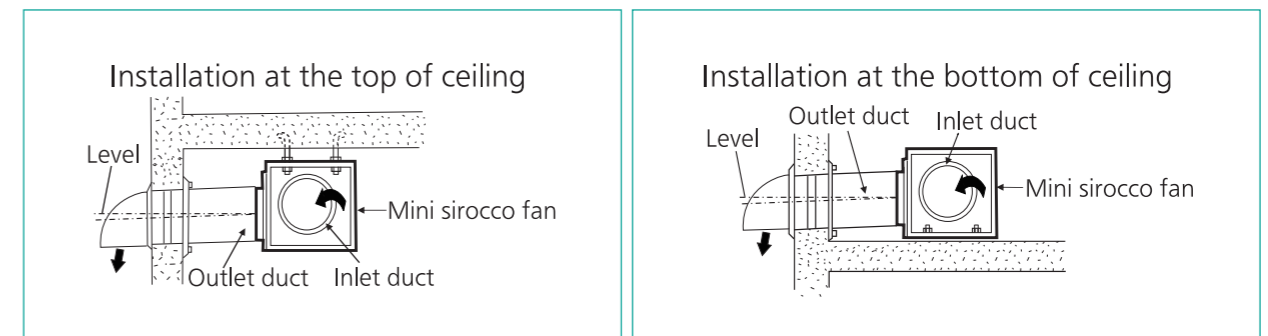

# Energy Recovery Ventilator

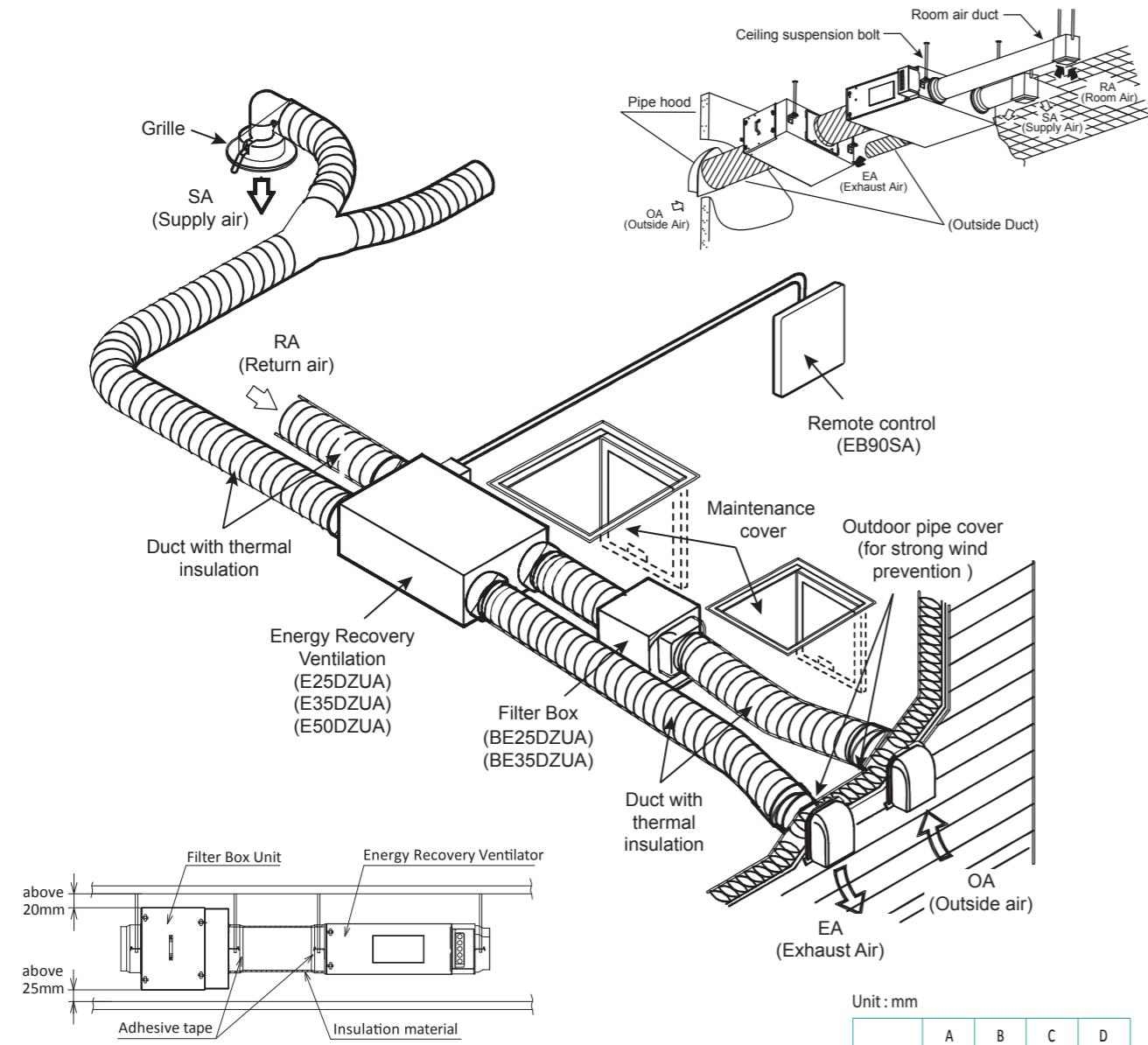

Unit : mm

	A	B	C	D
E25DZUA	695	693	853	649
E35DZUA	723	858	865	654
E50DZUA	723	1026	865	655

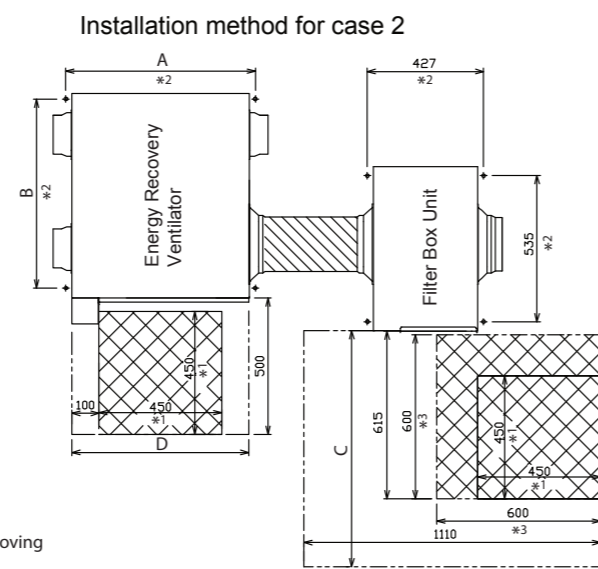
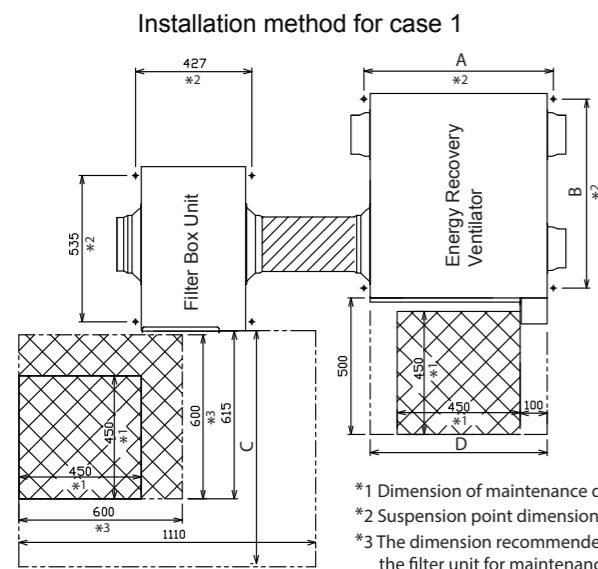

\*1 Dimension of maintenance door  
 \*2 Suspension point dimension  
 \*3 The dimension recommended to removing the filter unit for maintenance

# Thermo Ventilator

Applicable Model:  
**30BUC**

1. Open the cord cover and set the wiring

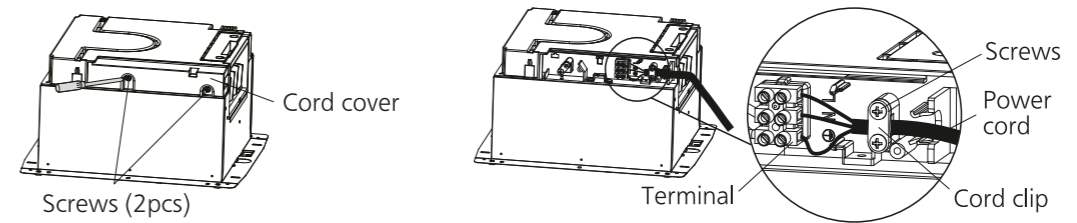

2. Install fan body in the ceiling

2.1 Installation with wooden joist

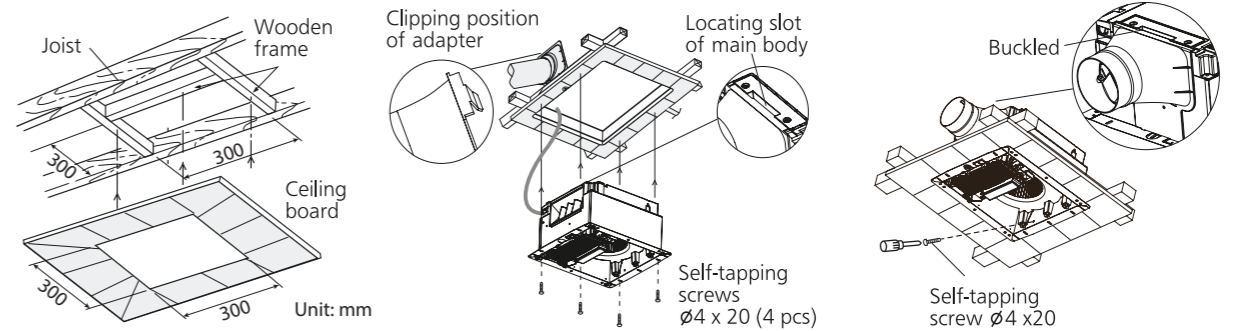

2.2 Installation with anchor bolts

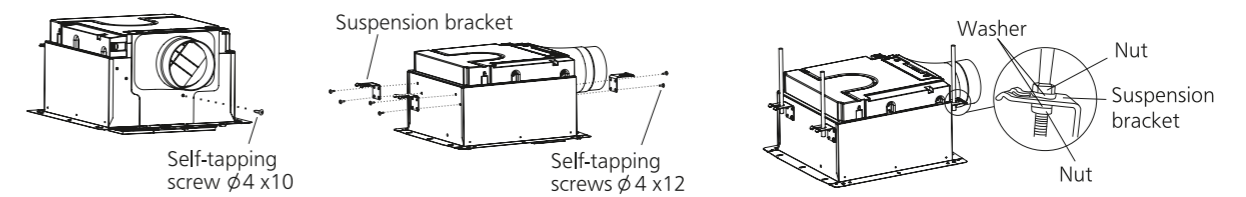

3. Set and tighten louver assembly with screws

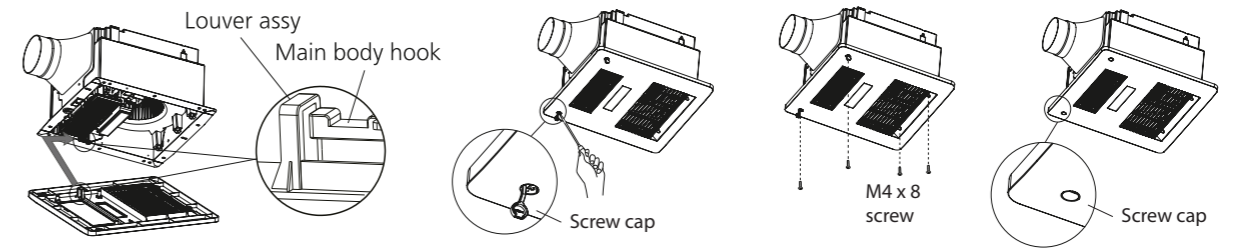

4. Set filter into the louver assembly

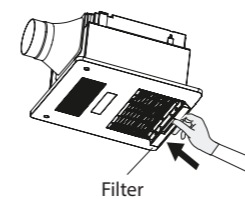

5. Connect duct pipe

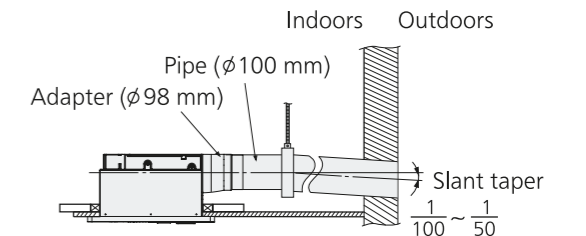

# Range Hood

Applicable Model:  
90HQUA

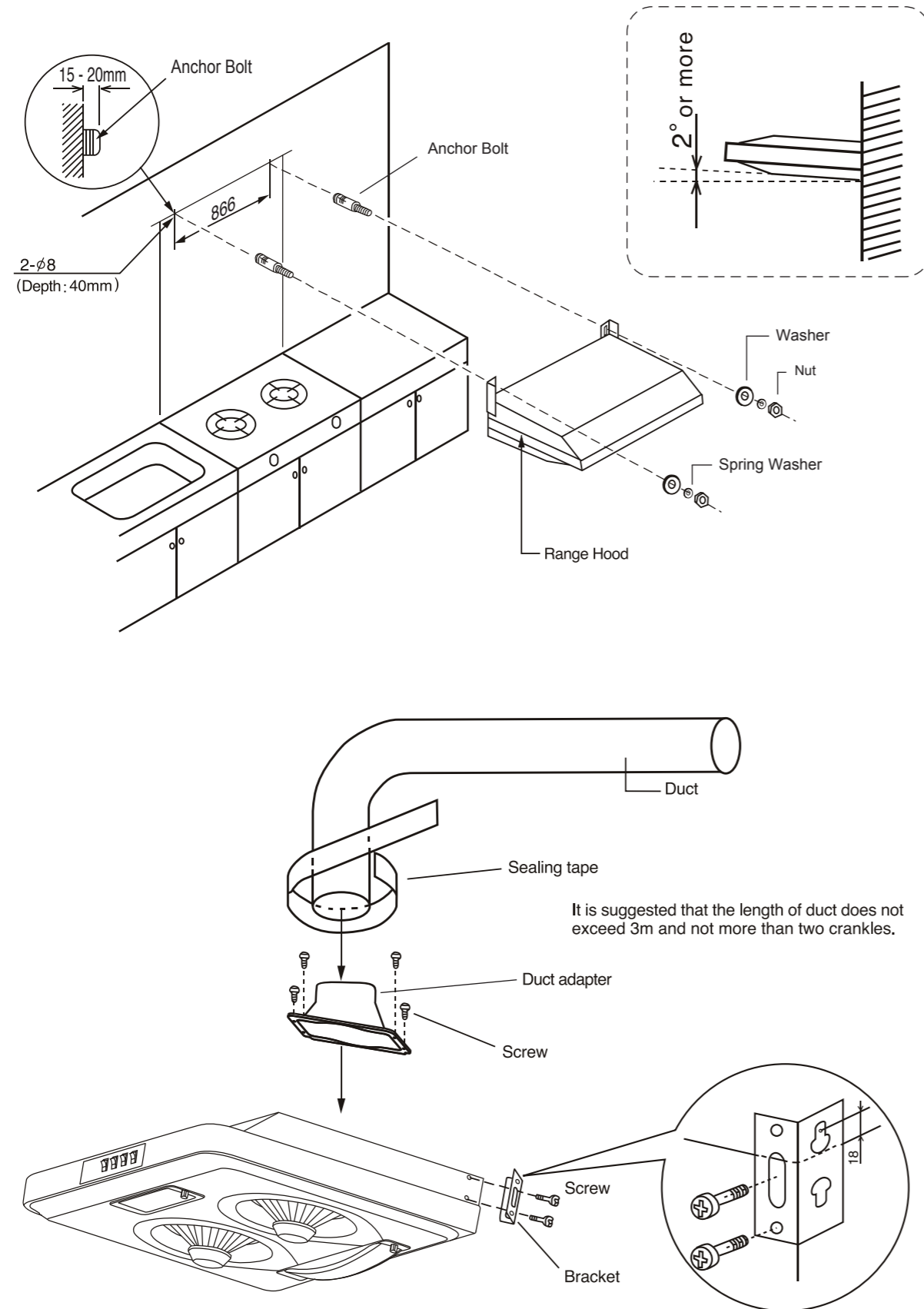

# Hand Dryer

Applicable Model:  
T09AC and T09BC

## 1. Install fixation board on the wall

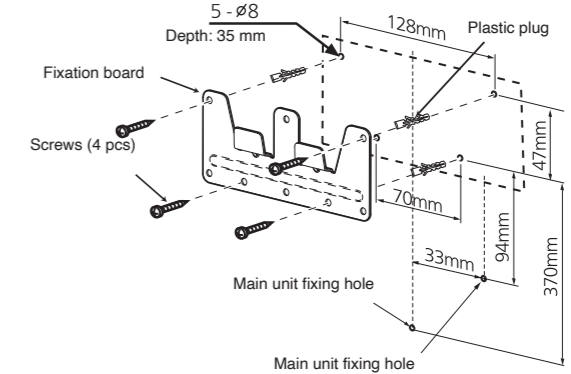
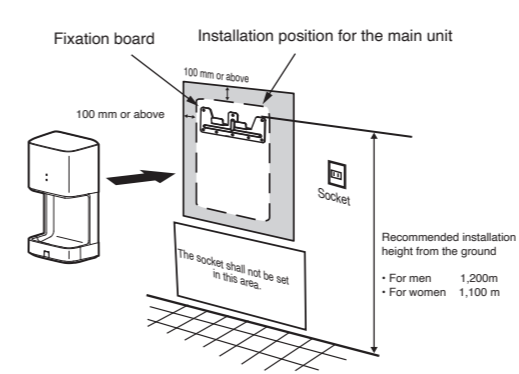

## 2. Adjust length and lead out direction of power cord

### I. Remove the fixing screws on the back baffle plate of the main unit

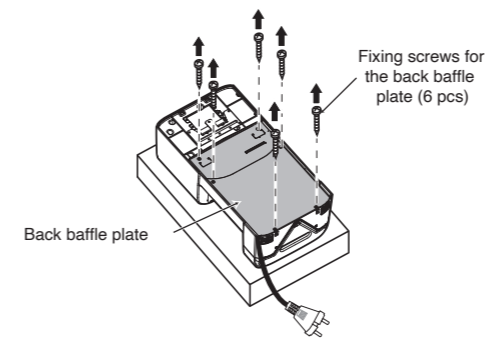

### II. Adjust the length of power cord by winding according to below figure, and select the lead-out direction

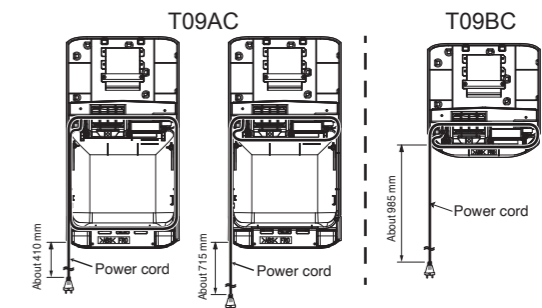

## 3. Set the main unit into the fixation board

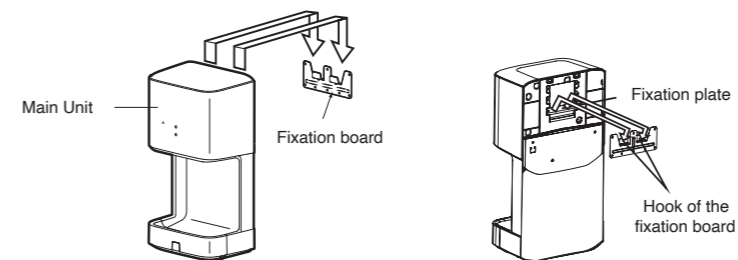

## 4. Fix the main unit with fixing screw

### For T09AC

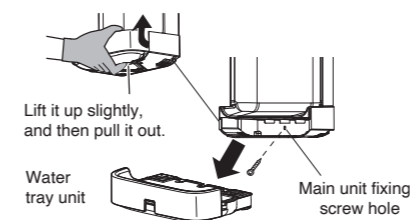

### For T09BC

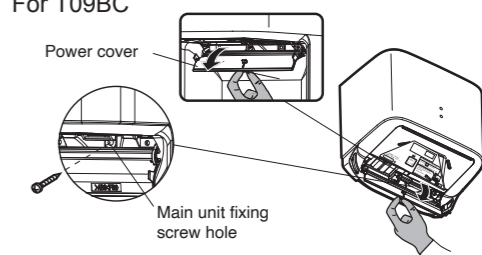

# Air Curtain

Applicable Model:  
Cross Flow Type

## 1. Install mounting plate on the wall

### I. Remove the mounting plate from rear of the product

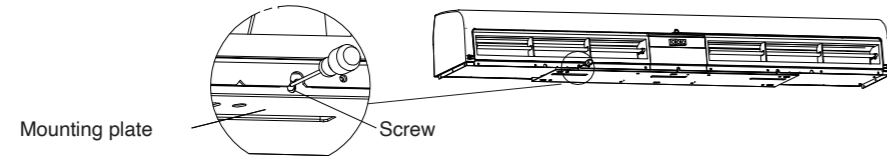

### II. Set the bolts on the wall

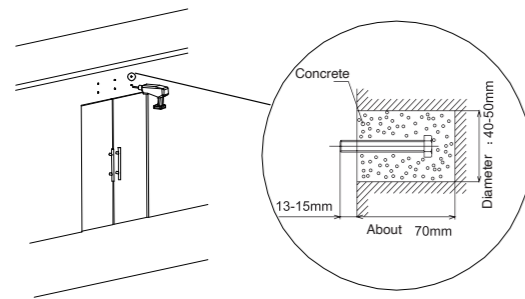

### III. Fix the mounting plate with washers and nuts

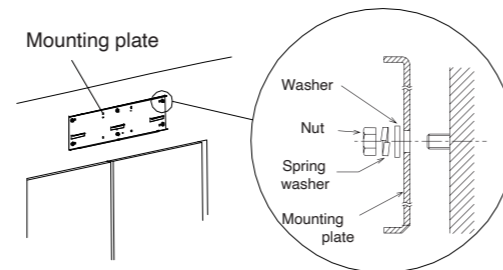

## 2. Wiring

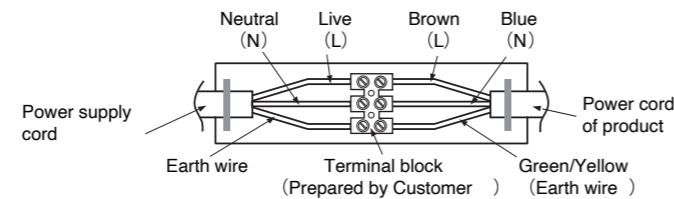
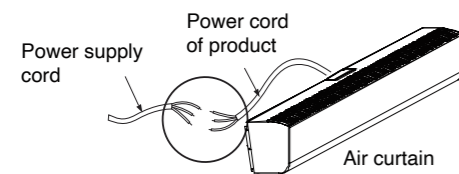

## 3. Install air curtain

### I. Hook the air curtain on the mounting plate and tighten the screws (x3)

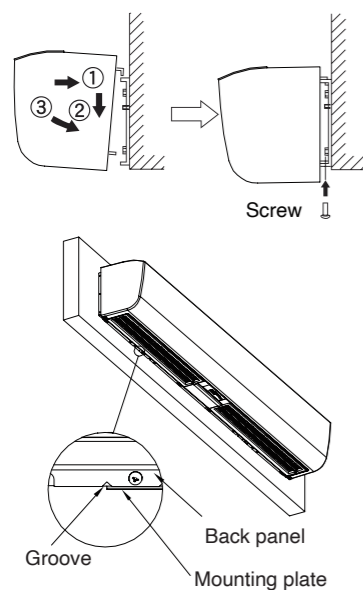

### II. Fix the contact sensor (for Sensor Series only)

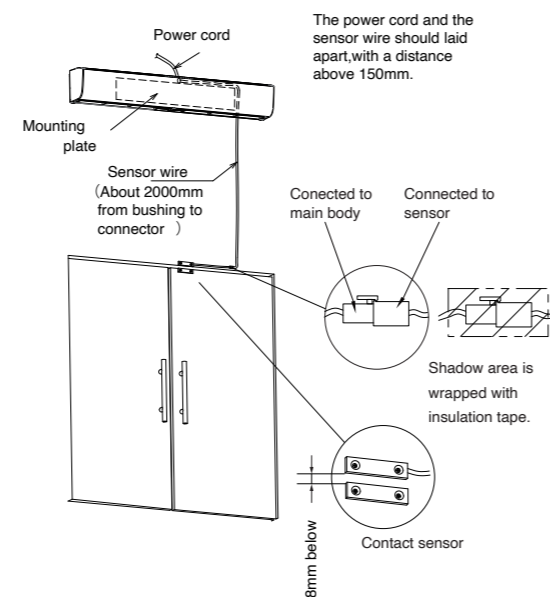

# Ceiling Fan

Applicable Model:  
Regulator Control Series

## (1) Assemble Pipe to Motor Assembly

### 1. Pull power cord (from power supply) and insert into the Pipe hole.

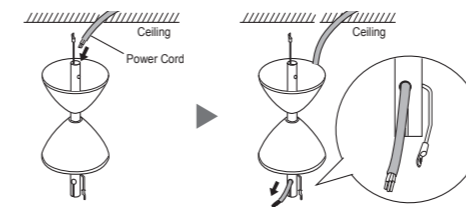

### 2. Ensure the Shaft Cap is set on the Motor Shaft and tighten with the Stopping Screw. Fit the Pipe to the Shaft Cap that the Pipe hole and the Motor Shaft hole are aligned.

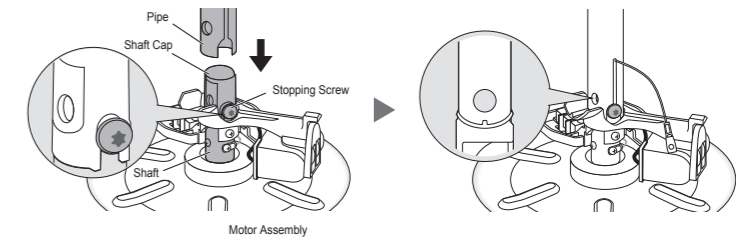

### 3. Fix the Pipe and Motor Assembly with a) Ellipse Bolt, b) P-R Washer, c) Spring Washer, d) Hexa Nut and e) Cotter Pin.

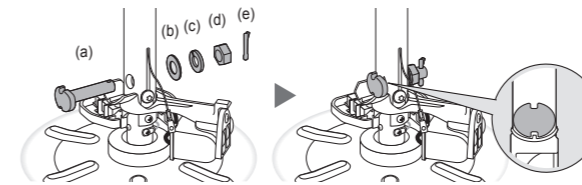

### 4. Bend the Cotter Pin.

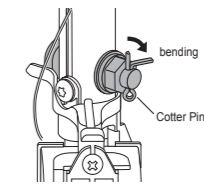

### 5. Fix Safety Wire to the Motor Shaft with Safety Wire Screw.

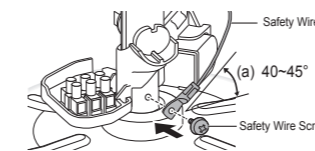

### 6. Connect the power cord to 3-pin Terminal.

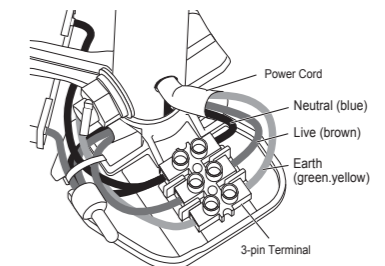

## (2) Install Blade Assembly

### 1. Remove Blade Screws from Motor Assembly. Set the Blade towards the Cover Hook and ensure the Blade Safety Plate is in proper position.

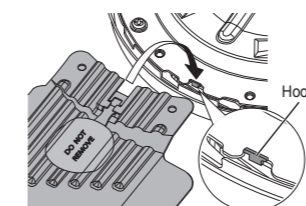

### 2. Tighten the Blade Screw firmly (2 screws per blade)

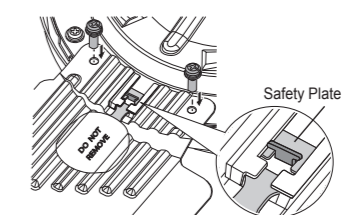

# Ceiling Fan

## (3) Install to the ceiling

1. Cross the C Hook of the Pulley Set to the Pipe and Place the Pulley on Ceiling Hook
2. Loop the Safety Wire to the ceiling hook and fix to the Pipe with the Safety Wire Screw

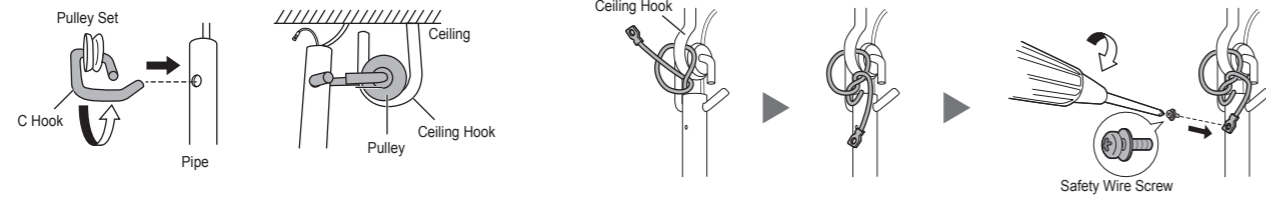

## (4) Fix the Canopy

1. Adjust Upper Canopy position and fix to the Pipe with screw.
2. Pull down the Lower Canopy until it stop and fix to the Pipe with screw.



## (5a) Install Speed Regulator (Slim Panel Regulator)

1. Insert the Live Wires (from supply source and Motor) into the 2 pin terminal of the regulator and tighten the terminal screw.
2. Set the Regulator to the wall regulator casing and fix with screws.



## (5b) Install Speed Regulator (Box Regulator)

1. Insert the Live Wires through the hole of Regulator Base and fix the base with the screws.
2. Insert the Live Wire (from supply source and Motor) into the 2 pin terminal of the regulator and tighten the terminal screw
3. Set the Regulator cover by inserting the protruding parts of the Regulator Base into the holes of Regulator Cover and fix with the screw

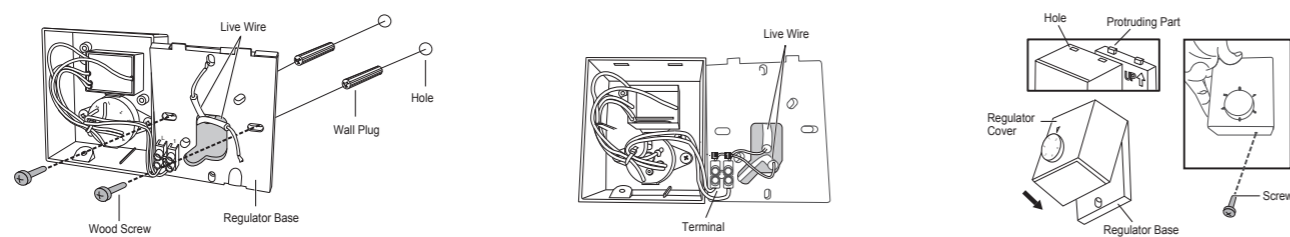

# Orbital Fan

## 1. Install fan stand on the ceiling

### I. Install mounting plate on the ceiling with the bolts (x2)

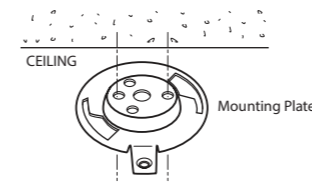

### II. Loop the safety wire around left arm of the stand and clip as (A)

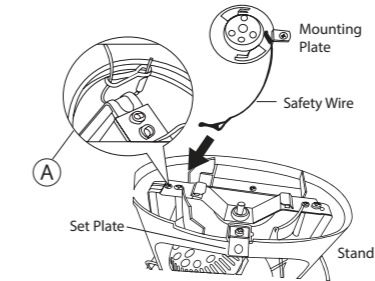

### III. Set the stand to the mounting plate. Align the screw hole and tighten the set screw

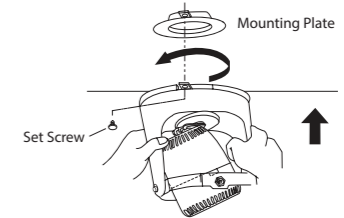

## 2. Assemble the fan

### I. Set rear guard on the stand by aligning the projection part to the hole

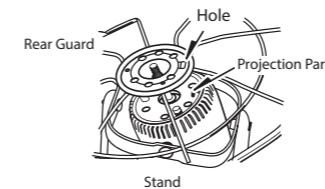

### II. Fit rear guard on the stand with wing bolt (2 pcs)

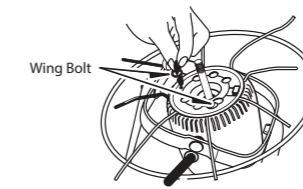

### III. Insert blade boss to the shaft. Ensure the groove is correctly fit to the shaft pin

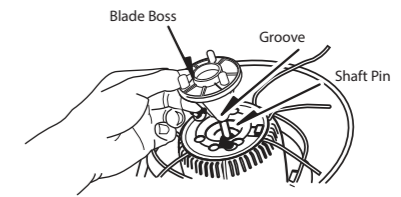

### IV. Set the blade to the blade boss and align the projection part to the hole of blade

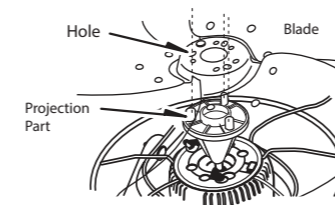

### V. Tighten the spinner to fix the blade



### VI. Set front guard to the rear guard and clip.

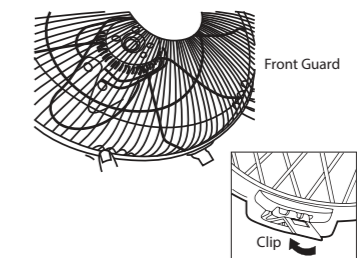

## 3. Install Regulator and Wiring

### I. Open the regulator cover and mount the regulator base on the wall

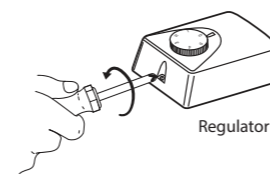

### II. Set the wiring according to the wiring diagram and re-assemble the regulator cover

