



SINCE 1909
JAPAN



KDK Ventilation Fans & Air Moving Equipment

Ventilation Fans & Air Moving Equipment

Refined Air Quality Solutions



KDK Company, Division of PES
4017, Takaki-cho, Kasugai, Aichi, Japan
<http://kdk.jp>

• Actual colors may vary slightly from those shown.
• Specifications are subject to change without prior notice.







CATALOG NO: K-MEVF003
December 2024

Page	Content
002	About KDK
003	Market Map
004	Product Certification
005	2024 Product Highlight
007	About Indoor Air Quality
009	Installation Simulation
011	Product Summary
021	Ceiling Mount Type Ventilation Fan
035	Wall Mount Type Ventilation Fan
047	Window Mount Type Ventilation Fan
055	Industrial Type Ventilation Fan
063	Cabinet Fan (In-line Fan)
071	Mini Sirocco Fan
079	Energy Recovery Ventilator
089	Thermo Ventilator
093	Range Hood
097	Hand Dryer
101	Air Curtain
109	Ceiling Fan / Electric Fan
121	Ventilation Product Specification Summary
131	Performance Data Summary
163	Project Reference
166	Installation Method

KDK was founded in 1909, with more than a century old history. By making a commitment to our business philosophy, we strive toward contributing to society through our air and wind technologies.

With the aims of offering the premium product and solution through good distributions and services, we will continue to maintain a leading position in the industry by utilizing advantages of our core competencies. With innovative technology and value-added approach, we are committed to make a reliable and quality product with excellent design and high safety standard in meeting the expectations of our customers all over the world.

Milestone

	— 1909	• KDK (Kawakita Denki Kigyousha) was founded
	— 1913	• Mass production of Typhoon Type Electric Fan
	— 1918	• Registration of KDK Trademark • Starting of export business
	1919	• Kawakita Denki Co. was established in Shanghai
	1933	• Chuou Denki Co., Ltd. was established in Osaka
	1956	• Osaka Denki Seiki Co., Ltd was established
	— 1960	• Registration of new KDK Trademark
	1962	• Renamed the company to Matsushita Seiko Co., Ltd
	1981	• Set up International Fan Manufacturing Co., Ltd [IFCO] in Hong Kong
	1989	• IFCO was renamed as Matsushita Seiko Hong Kong International Manufacturing co., Ltd [HIMCO]
	1993	• Set up Shunde Matsushita Seiko Co., Ltd [SHUMCO] in China. It was renamed as Guangdong Matsushita Seiko Co., Ltd. [GDMESC] in 2003 and further changed to PESGD in 2006
	1995	• Established Beijing Great Wall Matsushita Seiko Air Conditioning Equipment Co., Ltd. [BGMAC] which was renamed as PESGD-BJ in 2005
	1999	• Established Oversea Marketing Headquarter in HIMCO
	2003	• Matsushita Seiko Co. Ltd. was renamed as Matsushita Ecology Systems Co., Ltd. and further changed to KDK Company, Division of PES in 2008
	— 2009	• The 100th Anniversary of KDK
	2016	• Further expanded a brand-new product line of water pump for better living environment
	— 2019	• The 110th Anniversary of KDK
	2021	• PEWVN (Panasonic Electric Works Vietnam Co. Ltd.) was set up in Vietnam
	— 2024	• The 115th Anniversary of KDK

Market Map

For a century, KDK has established its business in various countries, building its reputation and brand value in the minds of its customers. Moving forward, in addition to continuous development in existing markets, we will explore new business in potential markets throughout other fast-growing regions.

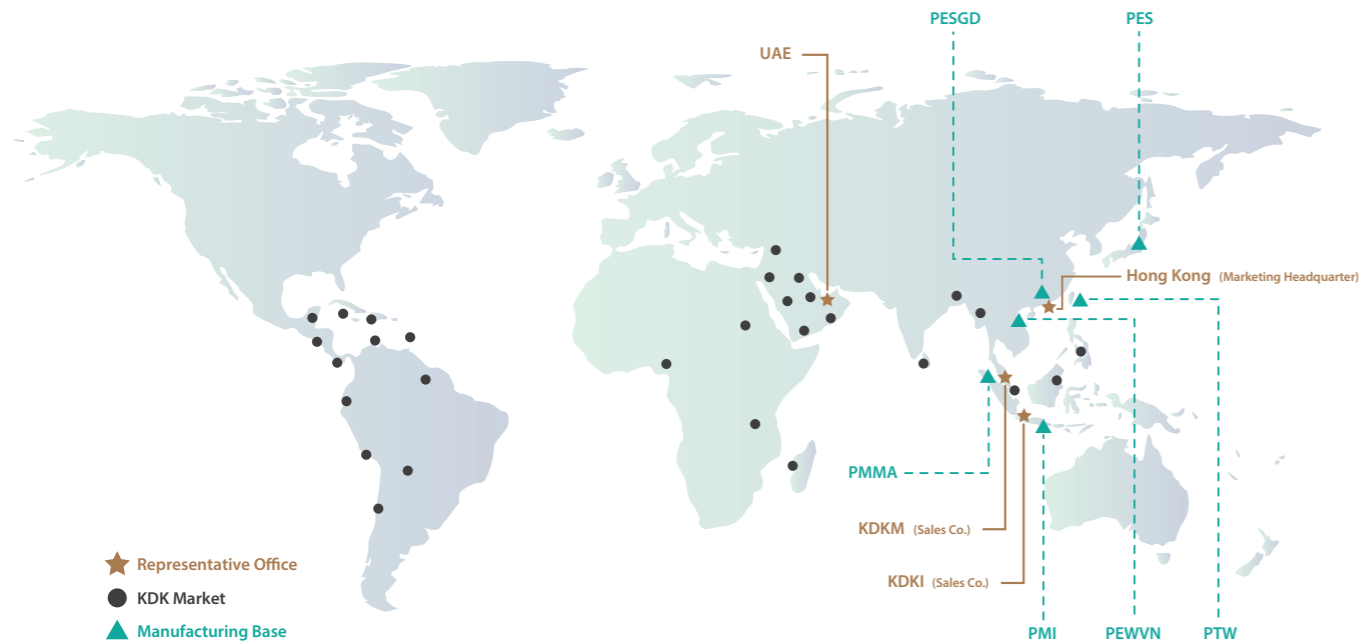

Distributor List

Country	Distributor
Iraq	Al Khait Alabydh Co
Jordan	Mohammad M Juma & Sons Co.
Kuwait	Salem M. Al-Nisf Electrical Co. W.L.L.
Oman	Mohsin Haider Darwish L.L.C.
Qatar	United Cooperation General Trading L.L.C.
Saudi Arabia	Abdulaziz & Sulaiman Saleh Al-Hakbany Sons Trading Co Haitham Est. for Trading
United Arab Emirates	Electra Abu Dhabi L.L.C. Electra Dubai
Yemen	Al Haj Mohamed Ali Sowaid & Sons
Nigeria	Polysonic Nigeria Ltd.
Sudan	Central Advanced Digitech Co.
Tanzania	Multi Cable Ltd.

Product Certification

To ensure safety, KDK products are designed and manufactured according to either the standards of JIS (Japan Industrial Standard) or IEC (International Electrotechnical Commission). Test certificates are awarded by recognized test laboratories that further prove the reliability of our products.



CB Test Certificate

CB Test Certificate is issued to products in compliance with the applicable requirement of IEC standard under CB Scheme (Certification Bodies' Scheme) set by IEC .

Beside the international standard of JIS and IEC, different safety certifications are also acquired to fulfill the requirement in different countries.

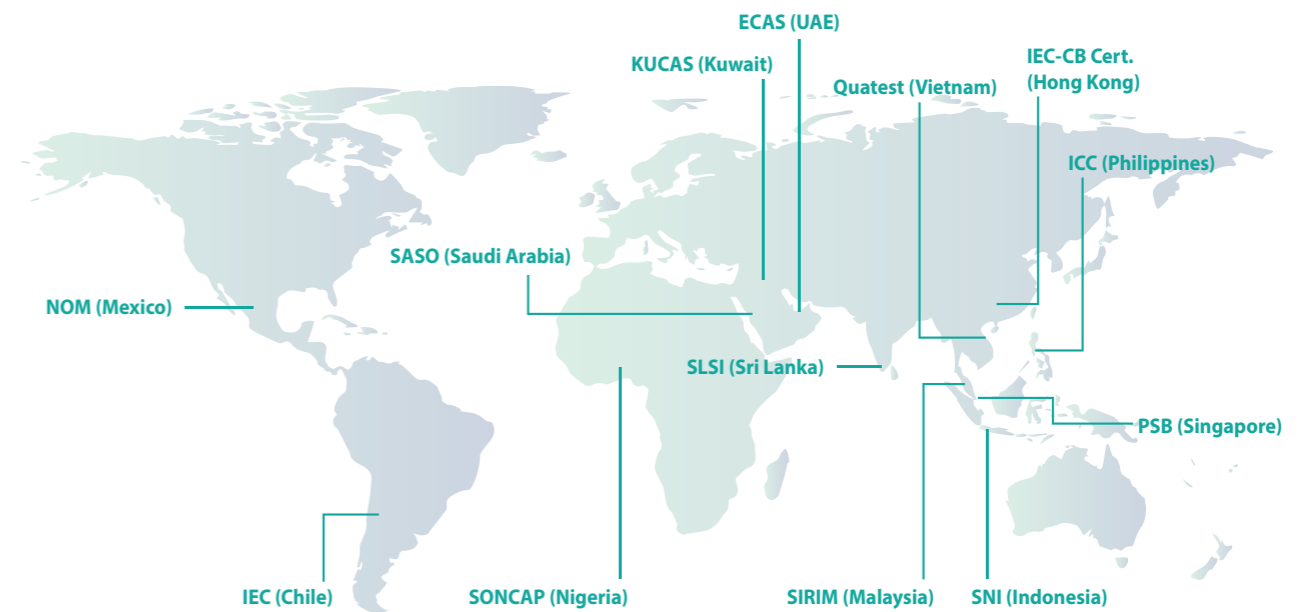

2024 Product Highlight

KDK Ventilation Fans

Empowering Every Moment Around the Clock.
Bringing 24-Hour Comfort, 365 Days of Fresh Air Excellence.



Reduce CO₂ Emission



Alleviate Global Warming



Reduce Electric Bill Expenditure

Constant Performance by Intelligent Technology



Fan is able to perform at constant airflow regardless of elbows in pipe.

Fan speed automatically increased to ensure the desired airflow.

Fan is able to perform as rated.



DC Motor



Energy Saving



Fresh Air



24JRB / 24JAB

Motor Type	DC Motor Model	AC Motor Model
Model	24JRB	24CUH
Static Pressure [Pa]	0	0
Air Volume [m ³ /h]	160	140
Power Consumption at 0 Pa [W]	7	13.5
Energy Efficiency [m ³ /h / Watt]	22.9	10.3

Power consumption comparison between DC motor series and non-DC motor series

Note: Values measured at 220V 60Hz.

High Air Volume Ceiling Mount Type Ventilation Fan

The Quiet Solution for Fresh Air



Quiet Operation

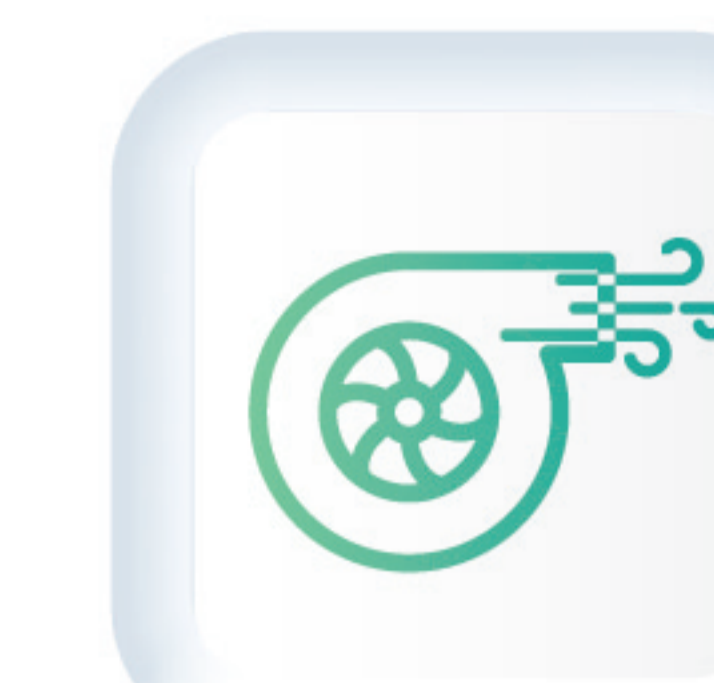

Effective Air Exhaust



24CXH

Powerful Exhaustion

Air volume up to
255 CMH

*Values measured at 220V 60Hz

KDK Thermo Ventilator

Embrace warmth, shielded from cold shocks, for cozy comfort every chilly day.



30BUC



Ventilation



Circulation



Heating



Clothes Drying



Reduce temperature difference between bathroom and corridor.

Reduce the risk of getting heat shock response.



IAQ

INDOOR AIR QUALITY

Air Supply
Air Exhaust
Air Circulation 3 core KDK solutions to enhance indoor air quality

The Importance of Indoor Air Quality

We care about the food we eat and the water that we drink, but what about AIR?
It is important to take care of the ONE thing we consume the most...

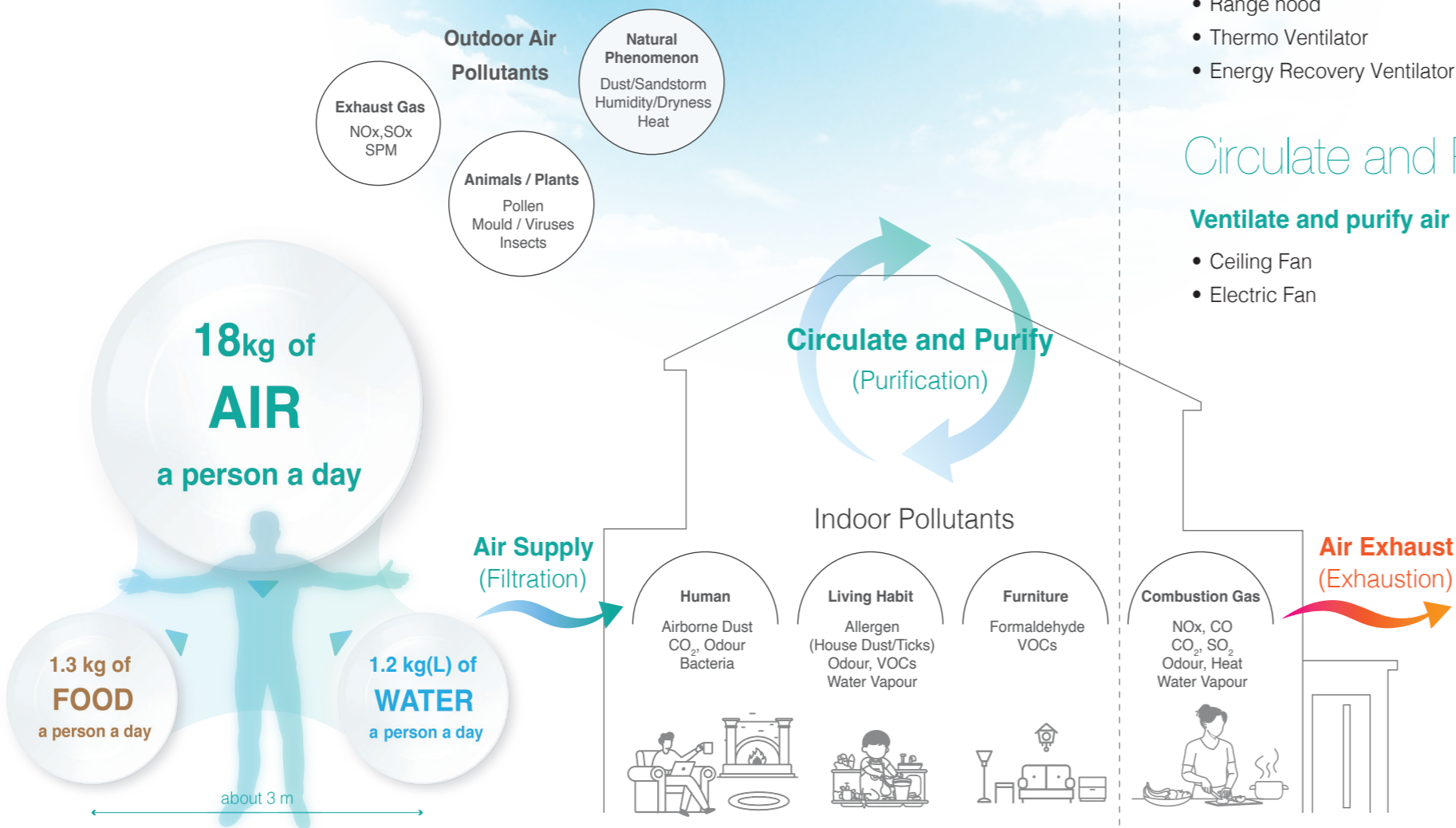

Ventilation

Air Supply

Prevent entrance of unwanted substances

- Energy Recovery Ventilator
- Ventilation Fan (reversible type)

Air Exhaust

Reduce unwanted substances indoor

- Ventilation Fan
- Range hood
- Thermo Ventilator
- Energy Recovery Ventilator

Circulate and Purify

Ventilate and purify air

- Ceiling Fan
- Electric Fan

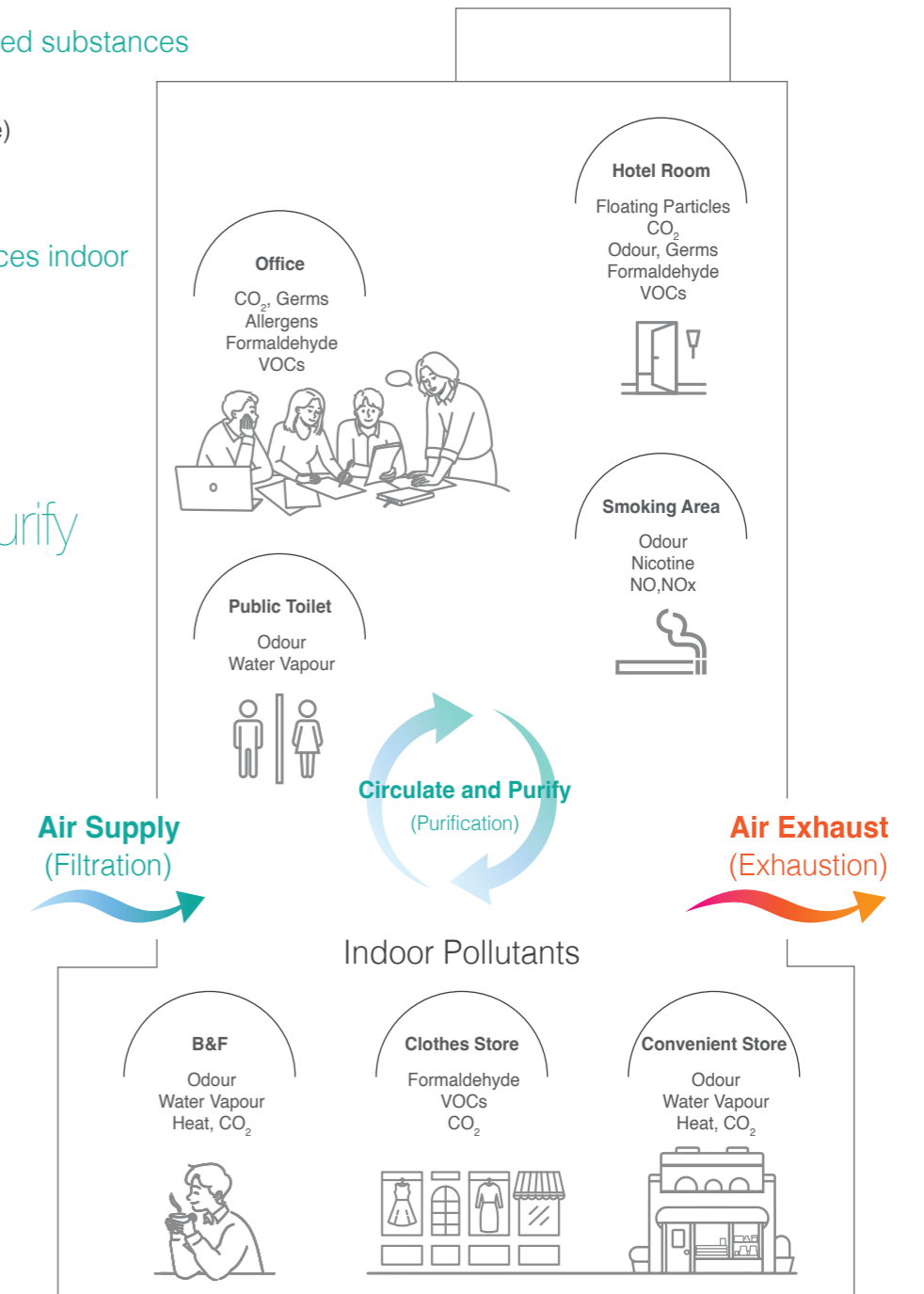







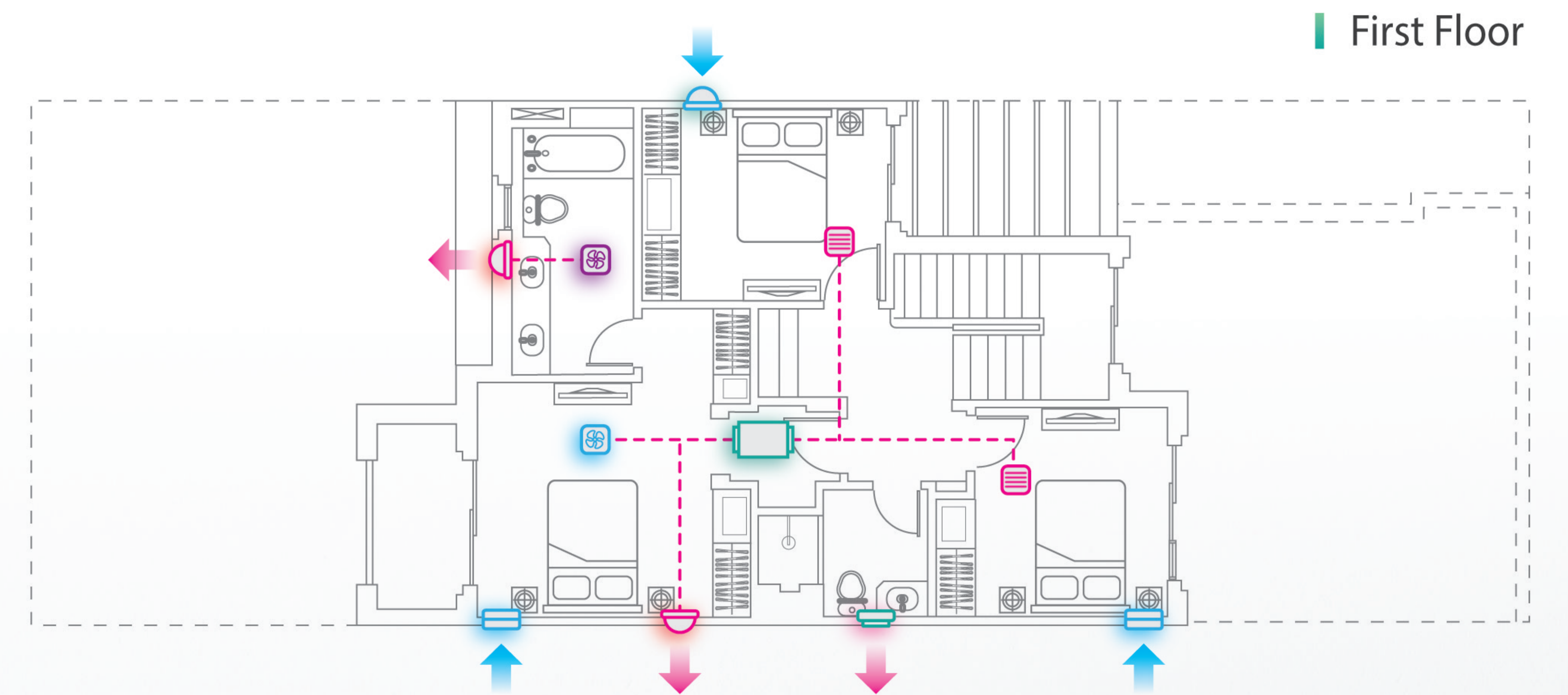
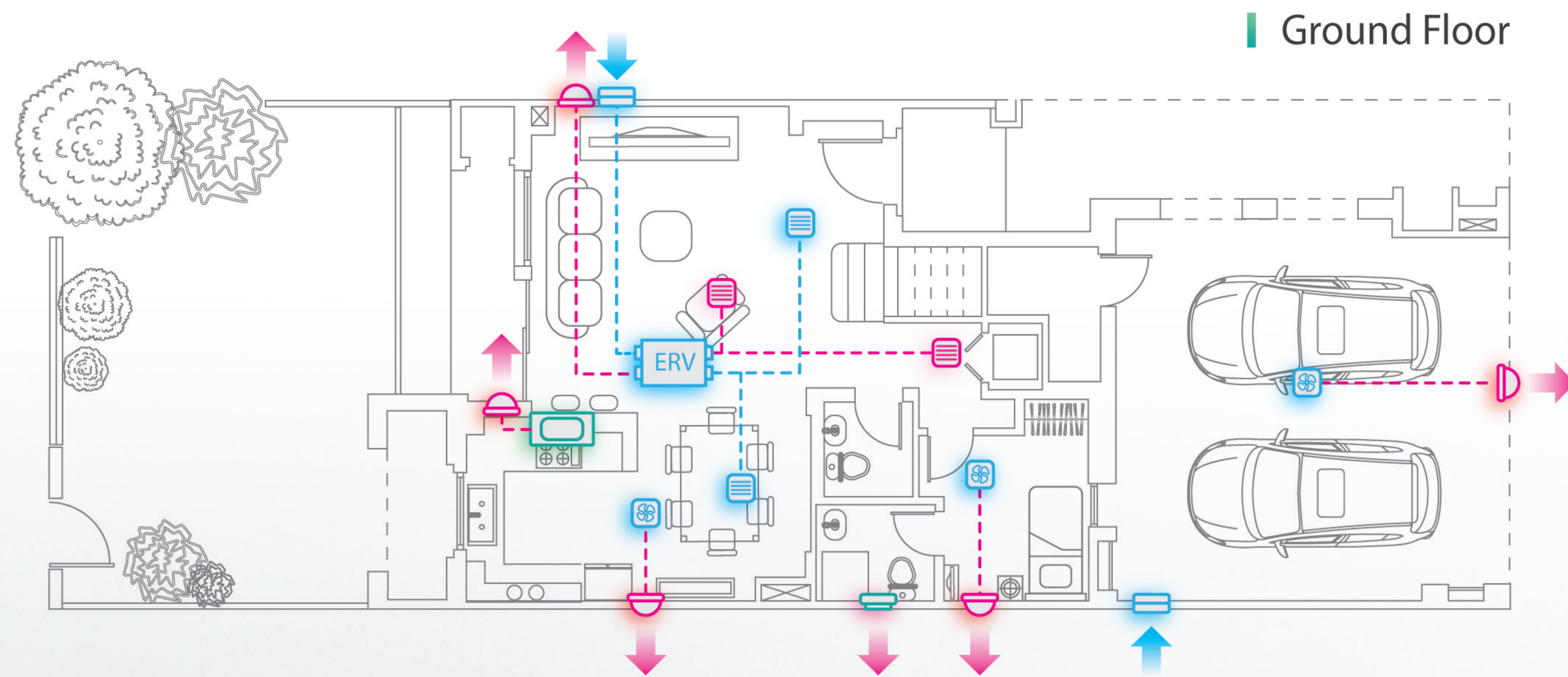



*1 "Air and Humans – From a Physiological Viewpoint" (1999) by UCHIYAMA Iwao (National Institute of Public Health of Japan)
 *2 "Heat Stroke Environmental Health Manual (2009)" from the Ministry of the Environment, Government of Japan
 *3 "Basic Data Sheet of Agriculture, Forestry, and Fisheries, Statistics Regarding The Food Self-Sufficiency Rate" from Ministry of Agriculture, Forestry and Fisheries of Japan

Redefining Your Indoor Environment













Installation Simulation (2-storey villa as example)















-  Ceiling Mount Type Ventilation Fan
-  Wall Mount Type Ventilation Fan
-  Cabinet Fan (In-line Fan)
-  Energy Recovery Ventilator
-  Thermo Ventilator
-  Range Hood
-  Intake Grille
-  Exhaust Grille
-  Vent Cap / Pipe Hood
-  Intake
-  Exhaust







Product Summary

Product	Series	Model	DC Motor	Super Low Noise Level	Fire Resistant	Voltage/ Frequency	Air Volume [CFM]	Consumption [W]	Page	
Ceiling Mount Type Ventilation Fan	DC Motor Series		24JRB	✓	-	-	220-240V/50Hz (Hi)	94	8	023
							220-230V/60Hz (Hi)	71	5.2	
							220-240V/50Hz (Lo)	47	3.6	
							220-230V/60Hz (Lo)	47	3.6	
			24JAB	✓	-	-	220-240V/50Hz (Hi)	94	8	024
							220-230V/60Hz (Hi)	71	5.2	
	220-240V/50Hz (Lo)						47	3.6		
	220-230V/60Hz (Lo)						47	3.6		
	Super Quiet Series		17CUH	-	✓	-	220V/50Hz	50	7.5	025
							220V/60Hz	50	10	
							230V/50Hz	50	8.5	
							230V/60Hz	50	10	
							240V/50Hz	53	9.5	
			24CUH	-	✓	-	220V/50Hz	82	10.5	026
							220V/60Hz	88	13.5	
							230V/50Hz	88	11	
							230V/60Hz	88	13.5	
							240V/50Hz	94	12	
							220V/50Hz	100	13.5	
			24CDH	-	✓	-	230V/50Hz	106	15	026
							230V/60Hz	106	19	
							240V/50Hz	112	16.5	
							220V/50Hz	118	16.5	
							220V/60Hz	118	20.5	
							230V/50Hz	124	18	
			24CHH	-	✓	-	230V/60Hz	118	22.5	027
							240V/50Hz	124	19.5	
							220V/50Hz	138	24	
							220V/60Hz	150	29	
							230V/50Hz	141	26.5	
							240V/50Hz	147	29	
			27CHH	-	✓	-	220V/50Hz (Hi)	194	28	028
							220V/50Hz (Lo)	153	23	
							220V/60Hz (Hi)	194	33	
							220V/60Hz (Lo)	159	26	
							230V/50Hz (Hi)	200	31.5	
							230V/50Hz (Lo)	162	25.5	
							240V/50Hz (Hi)	212	34	
	240V/50Hz (Lo)						171	27.5		
	220V/50Hz (Hi)						253	36		
	220V/50Hz (Lo)						177	28		
		32CDH	-	✓	-	220V/60Hz (Hi)	241	35.5	029	
						220V/60Hz (Lo)	168	27.5		
						230V/50Hz (Hi)	259	37.5		
						230V/50Hz (Lo)	185	29		
240V/50Hz (Hi)						277	38.5			
240V/50Hz (Lo)						194	30			
220V/50Hz (Hi)						377	90			
220V/50Hz (Lo)						253	66			
220V/60Hz (Hi)						371	98			
220V/60Hz (Lo)						241	66.4			
Standard Series		38CDG/ 38CDG 05	-	-	-	230V/50Hz (Hi)	397	96	030	
						230V/50Hz (Lo)	259	72		
						240V/50Hz (Hi)	412	104		
						240V/50Hz (Lo)	277	78		
						220V/50Hz (Hi)	471	122		
						220V/50Hz (Lo)	309	89		
		38CHG	-	-	-	220V/60Hz (Hi)	465	138	031	
						220V/60Hz (Lo)	294	90		
						230V/50Hz (Hi)	471	122		
						230V/50Hz (Lo)	277	84		
						240V/50Hz (Hi)	491	132		
						240V/50Hz (Lo)	288	90		
Metal Series		24CMUA	-	-	✓	220V/50Hz	53	11	032	
						220V/60Hz	59	12		
						230V/50Hz	56	12		
		24CMHA	-	-	✓	240V/50Hz	59	13	032	
						220V/50Hz	106	20		
						220V/60Hz	106	23		
		27CMHA	-	-	✓	230V/50Hz	112	22	033	
						240V/50Hz	118	25		
						220V/50Hz	212	35		
220V/60Hz						224	43			
230V/50Hz						224	38			
240V/50Hz						235	43			











Product	Series	Model	Silent Stream Fan	Auto Shutter	Louver	Voltage/ Frequency	Air Volume [CFM]	Consumption [W]	Page		
Wall Mount Type Ventilation Fan	Metallic Series		20ASB/ 20ASB 05	-	✓	-	220V/50Hz	304	17	037	
							220V/60Hz	360	21.5		
							230V/50Hz	311	18.1		
							240V/50Hz	318	19.5		
							220V/50Hz	505	25		
							220V/60Hz	562	30.5		
			25ASB/ 25ASB 05	-	✓	-	230V/50Hz	509	27.3		037
							240V/50Hz	523	29.5		
							220V/50Hz	696	29.5		
							220V/60Hz	685	34.5		
							230V/50Hz	735	31.7		
							240V/50Hz	759	34		
		30ASB/ 30ASB 05	-	✓	-	220V/50Hz	685	34.5	037		
						230V/50Hz	735	31.7			
						240V/50Hz	759	34			
						220V/50Hz	170	15			
						220V/60Hz	180	19			
						230V/50Hz	173	17			
		15AAQ1	-	✓	-	240V/50Hz	180	19	038		
						220V/50Hz	170	15			
						220V/60Hz	180	19			
						230V/50Hz	173	17			
	Automatic Shutter Series		20AUA	✓	✓	-	220-230V/50Hz	347-359	18-19.5	039	
							220-240V/50Hz	347-365	18-21.5		
							220V/60Hz	400	22		
							230V/60Hz	418	23.5		
							220-230V/50Hz	559-571	25-27		
							220-240V/50Hz	559-571	25-29		
			25AUA	✓	✓	-	220V/60Hz	571	31		039
							230V/60Hz	612	35		
							220-230V/50Hz	706-736	28-30		
							220-240V/50Hz	706-765	28-32.5		
							220V/60Hz	706	33		
							230V/60Hz	765	36		
		30AUA	✓	✓	-	220V/50Hz	341	22	040		
						220V/60Hz	383	29			
						220V/50Hz	541	29			
						220V/60Hz	553	33			
						220V/50Hz	706	29			
						220V/60Hz	671	33			
	Automatic Shutter Series		20AUH	-	✓	-	220-230V/50Hz	324-327	18-19.5	041	
							220-240V/50Hz	324-330	18-21.5		
							220V/60Hz	359	22		
							230V/60Hz	371	23.5		
							220-230V/50Hz	494-506	25-27		
220-240V/50Hz							494-518	25-30			
		25ALA	✓	✓	✓	220V/60Hz	506	31	041		
						230V/60Hz	536	34			
						220-230V/50Hz	589-618	28-30			
						220-240V/50Hz	589-647	28-32.5			
						220V/60Hz	589	33			
						230V/60Hz	618	36			
	30ALA	✓	✓	✓	220V/50Hz	321	22	042			
					220V/60Hz	353	29				
					220V/50Hz	491	29				
					220V/60Hz	498	33				
					220V/50Hz	550	29				
					220V/60Hz	539	33				
	20ALH	-	✓	✓	220V/50Hz	321	22	042			
					220V/60Hz	353	29				
					220V/50Hz	491	29				
					220V/60Hz	498	33				
					220V/50Hz	550	29				
					220V/60Hz	539	33				
	25ALH	-	✓	✓	220V/50Hz	321	22	042			
					220V/60Hz	353	29				
					220V/50Hz	491	29				
					220V/60Hz	498	33				
					220V/50Hz	550	29				
					220V/60Hz	539	33				
	30ALF 11	-	✓	✓	220V/50Hz	321	22	042			
					220V/60Hz	353	29				
					220V/50Hz	491	29				
					220V/60Hz	498	33				
					220V/50Hz	550	29				
					220V/60Hz	539	33				



Product Summary

Product	Series	Model	Silent Stream Fan	Auto Shutter	Louver	Voltage/Frequency	Air Volume [CFM]	Consumption [W]	Page					
Wall Mount Type Ventilation Fan	Plastic Series		10BAQ1	-	-	✓	220V/50Hz	45	15	043				
							220V/60Hz	43	17					
							230V/50Hz	47	16					
							240V/50Hz	50	17.5					
							240V/50Hz	50	17.5					
	Bathroom Series		10EGKB	-	-	✓	220V/50Hz	45	4.3	045				
							230V/50Hz	45	4.6					
							240V/50Hz	45	5.0					
							15EGKB	-	-		✓	220V/50Hz	95	5.7
												230V/50Hz	97	6.1
												240V/50Hz	97	6.5
		10EGSB	-	-	✓	220V/50Hz	45	4.3	046					
						220V/60Hz	51	4.7						
						230V/50Hz	45	4.6						
						240V/50Hz	45	5.0						
						15EGSB	-	-		✓	220V/50Hz	91	5.7	
											220V/60Hz	106	6.1	
											230V/50Hz	94	6.1	
											240V/50Hz	97	6.5	





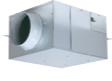
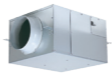
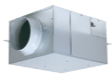
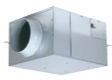

Product	Series	Model	Electrically Operated Shutter	Auto Shutter	Cord-operated Shutter	Voltage/Frequency	Air Volume [CFM]	Consumption [W]	Page				
Window Mount Type Ventilation Fan	Electric Shutter Series		✓	-	-	220V/50Hz	135	13	050				
						220V/60Hz	135	13					
						230V/50Hz	135	14					
						240V/50Hz	135	15					
						20WHCT	✓	-		-	220V/50Hz	262	20
											220V/60Hz	283	22
	230V/50Hz	262	21										
	240V/50Hz	262	22										
	Automatic Shutter Series		15WAA	-	✓	-	220V/50Hz	124	14	052			
							220V/60Hz	131	18				
							230V/50Hz	131	15				
			15WAA/15WAAMN	-	✓	-	240V/50Hz	134	16				
							220V/50Hz	224	15				
			20WAA	-	✓	-	220V/60Hz	224	17				
							230V/50Hz	230	16				
							240V/50Hz	237	17.5				
							20WAA/20WAAMN	237	17.5				
	Cord-operated Shutter Series		15WUD	-	-	✓	220V/50Hz	124	8.1	054			
							220V/60Hz	118	8.9				
							230V/50Hz	129	8.8				
15WUD/15WUDMN			-	-	✓	240V/50Hz	135	9.5					
						220V/50Hz	212	16.4					
20WUD			-	-	✓	220V/60Hz	212	19					
						230V/50Hz	224	17.9					
						240V/50Hz	235	19.5					
						20WUD/20WUDMN	235	19.5					

Product Summary

Product	Series	Model	Reversible	Durable Powder Coating	Shutter	Metal Large Blade Assembly	Voltage/Frequency	Air Volume [CFM]	Consumption [W]	Page			
Industrial Ventilation Fan	Shutter Series		40KAQA	-	✓	✓	✓	220V/50Hz	1,105	47	056		
								230V/50Hz	1,130	52			
								240V/50Hz	1,155	59			
								230V/60Hz	1,254	67			
	High Pressure Series			25GSE	✓	✓	Optional	-	220V/50Hz	753	41	057	
									220V/60Hz	848	57		
									230V/50Hz	753	43		
									240V/50Hz	753	44		
				30GSE	✓	✓	Optional	-	220V/50Hz	1,265	87		057
									220V/60Hz	1,407	119		
									230V/50Hz	1,265	92		
									240V/50Hz	1,265	98		
				35GSE	✓	✓	Optional	-	220V/50Hz	1,736	113		058
									220V/60Hz	1,989	161		
									230V/50Hz	1,736	118		
									240V/50Hz	1,736	122		
			40GSE	✓	✓	Optional	-	220V/50Hz	2,295	141	058		
								220V/60Hz	2,878	270			
								230V/50Hz	2,295	146			
								240V/50Hz	2,295	151			
				45GSC	✓	✓	Optional	-	220V/50Hz	3,061	227	059	
									220V/60Hz	3,514	325		
									230V/50Hz	3,196	235		
									240V/50Hz	3,214	241		
		50GSC	✓	✓	Optional	-	220V/50Hz	3,608	249	059			
							220V/60Hz	4,179	326				
							230V/50Hz	3,779	258				
							240V/50Hz	3,814	271				
		60GSC	✓	✓	Optional	-	220V/50Hz	4,732	245	060			
							220V/60Hz	5,539	361				
							230V/50Hz	4,979	258				
							240V/50Hz	4,997	263				
		45GTC	✓	✓	Optional	-	380V/50Hz	3,249	220	060			
							380V/60Hz	3,779	330				
			50GTC	✓	✓	Optional	-	380V/50Hz	4,097	320	060		
								380V/60Hz	4,715	475			
								380V/50Hz	5,544	310			
								380V/60Hz	6,427	450			

Product	Series	Model	Twin Flow Fan	Noise Absorption Material	Single Phase	Three Phase	Voltage/Frequency	Air Volume [CFM]	Consumption [W]	Page	
Cabinet Fan	Standard Series		12NSB	✓	✓	✓	-	220V/50Hz (Hi)	106	18	065
								220V/50Hz (Lo)	85	17	
								220V/60Hz (Hi)	112	23	
								220V/60Hz (Lo)	85	19	
								230V/50Hz (Hi)	106	20	
								230V/50Hz (Lo)	88	18	
		240V/50Hz (Hi)	109	22							
		240V/50Hz (Lo)	91	19							
		15NSB	220V/50Hz (Hi)	200	33						
			220V/50Hz (Lo)	162	29.5						
			220V/60Hz (Hi)	218	42						
			220V/60Hz (Lo)	153	33						
	230V/50Hz (Hi)		200	35							
	230V/50Hz (Lo)		165	31							
	066		18NSB	✓	✓	✓	-	220V/50Hz (Hi)	294	60	066
								220V/50Hz (Lo)	238	55	
								220V/60Hz (Hi)	288	73	
								220V/60Hz (Lo)	277	62.5	
								230V/50Hz (Hi)	294	65	
								230V/50Hz (Lo)	247	58.5	
		240V/50Hz (Hi)	300	68							
		240V/50Hz (Lo)	253	62.5							
		18NFB	220V/50Hz (Hi)	453	91						
			220V/50Hz (Lo)	365	80						
			220V/60Hz (Hi)	447	119						
			220V/60Hz (Lo)	341	87						
	230V/50Hz (Hi)		453	96							
	230V/50Hz (Lo)		365	82							
	067		20NSB	✓	✓	✓	-	220V/50Hz (Hi)	541	120	067
								220V/50Hz (Lo)	424	113	
								220V/60Hz (Hi)	506	159	
								220V/60Hz (Lo)	365	128	
								230V/50Hz (Hi)	547	125	
								230V/50Hz (Lo)	441	120	
		23NLB	240V/50Hz (Hi)	553	135						
			240V/50Hz (Lo)	465	125						
			220V/50Hz (Hi)	706	230						
			220V/50Hz (Lo)	530	170						
			220V/60Hz (Hi)	647	310						
			220V/60Hz (Lo)	471	190						
	068		25NSB	✓	✓	✓	-	230V/50Hz (Hi)	706	250	068
								230V/50Hz (Lo)	530	180	
								240V/50Hz (Hi)	736	260	
								240V/50Hz (Lo)	559	190	
								220V/50Hz (Hi)	1,001	345	
								220V/50Hz (Lo)	812	265	
		25NFB	220V/60Hz (Hi)	971	425						
			220V/60Hz (Lo)	706	300						
230V/50Hz (Hi)			1,012	350							
230V/50Hz (Lo)			812	270							
240V/50Hz (Hi)			1,030	370							
240V/50Hz (Lo)			853	290							
069		25SWC	✓	✓	-	✓	220V/50Hz (Hi)	1,118	390	069	
							220V/50Hz (Lo)	942	325		
							220V/60Hz (Hi)	1,065	520		
							220V/60Hz (Lo)	824	380		
							230V/50Hz (Hi)	1,124	410		
							230V/50Hz (Lo)	942	335		
	25SMC	240V/50Hz (Hi)	1,130	430							
		240V/50Hz (Lo)	953	360							
		380V/50Hz	2,354	940							
		380V/60Hz	2,649	1,450							
		415V/50Hz	2,354	1,000							
		440V/50Hz	2,354	1,000							
070		28NXC	✓	✓	-	✓	380V/50Hz	3,061	1,180	070	
							380V/60Hz	3,237	1,750		
							415V/50Hz	3,061	1,260		
							440V/50Hz	3,061	1,260		
							380V/50Hz	1,530	600		
							380V/60Hz	1,560	840		
415V/50Hz	1,530	650									
440V/50Hz	1,530	650									



Product Summary

Product		Model	Single Phase	Adjustable Outlet Direction	Page
Mini Sirocco Fan		10CGB	✓	✓	073
		12CGB	✓	✓	
		14CGB	✓	✓	
		16CGB	✓	✓	
		17CGB	✓	✓	
		19CGB	✓	✓	
		21CGB	✓	✓	



Product	Model	Counter-flow Heat-exchange	Bypass Ventilation	Interlock with Air Conditioning	Voltage/Frequency	Notch	Air Volume [CFM]	Consumption [W]	Exchange Efficiency				Page
									Temperature		Enthalpy		
									Cooling	Heating	Cooling	Heating	
Energy Recovery Ventilator		✓	✓	✓	220V/60Hz	SH	147	157	60	75	61	67	085
						H	147	148	60	75	61	67	
						L	88	82	65	77	70	74	
	E35DZUA	✓	✓	✓	220V/60Hz	SH	206	282	53	78	66	71.5	086
						H	206	253	53	78	66	71.5	
						L	150	172	53	75	64	70	
	E50DZUA	✓	✓	✓	220V/60Hz	SH	294	376	53	78	66	70	087
						H	294	349	53	78	66	70	
						L	206	215	58	78	66	69	









Product	Model	Ventilation	Circulation	Heating	Clothes Drying	Voltage/Frequency	Air Volume		Page	
							[CMH]	[CFM]		
Thermo Ventilator		30BUC	✓	✓	✓	✓	220V/60Hz	160	94	091

Product	Twin Motor Series	Model	2-speed Selection	Slim Design	Voltage/Frequency	Air Volume		RPM	Page
						[CMH]	[CFM]		
Range Hood		90HQUA	✓	✓	220V/50Hz (Hi)	785	462	993	095
					220V/50Hz (Lo)	484	285	570	
					220V/60Hz (Hi)	779	459	905	
					220V/60Hz (Lo)	464	273	594	
					240V/50Hz (Hi)	775	456	911	
					240V/50Hz (Lo)	523	308	-	

Product	Standard Series	Model	Quick Response Sensor	Lamp Super alleru-buster Filter	ON/OFF Switch for Heater	Safety Check Indicator	Voltage/Frequency	Air Velocity [m/s]	Page
Hand Dryer		T09AC	✓	✓	✓	✓	220V/50Hz	90 - 110	099
							220V/60Hz	90 - 110	
							230V/50Hz	90 - 110	
							230V/60Hz	90 - 110	
		T09BC	✓	✓	✓	✓	220V/50Hz	90 - 110	
							220V/60Hz	90 - 110	
							230V/50Hz	90 - 110	
							230V/60Hz	90 - 110	

Product Summary

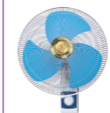
Product	Type	Series	Model	Cross Flow Fan	Sirocco Fan	Meta Blade Bush	Air Deflection Plate	2-speed Selection	Remote Control	Door Contact Sensor	Push Button Switch	Page	
Air Curtain	Cross Flow Type	Remote Control Series	 3009GA	✓	-	✓	✓	✓	✓	-	-	103	
			4009GA	✓	-	✓	✓	✓	✓	-	-		
			3012GA	✓	-	✓	✓	✓	✓	-	-		
			4012GA	✓	-	✓	✓	✓	✓	-	-		
			3015GA	✓	-	✓	✓	✓	✓	-	-		
			4015GA	✓	-	✓	✓	✓	✓	-	-		
		Sensor Series	 3009DA	✓	-	✓	✓	✓	-	✓	-	-	104
			4009DA	✓	-	✓	✓	✓	-	✓	-	-	
			3012DA	✓	-	✓	✓	✓	-	✓	-	-	
			4012DA	✓	-	✓	✓	✓	-	✓	-	-	
			3015DA	✓	-	✓	✓	✓	-	✓	-	-	
			4015DA	✓	-	✓	✓	✓	-	✓	-	-	
	Standard Series	 3009UA	✓	-	✓	✓	✓	-	-	✓	-	105	
		4009UA	✓	-	✓	✓	✓	-	-	✓	-		
		3012UA	✓	-	✓	✓	✓	-	-	✓	-		
		4012UA	✓	-	✓	✓	✓	-	-	✓	-		
		3015UA	✓	-	✓	✓	✓	-	-	✓	-		
		4015UA	✓	-	✓	✓	✓	-	-	✓	-		
	Sirocco Type	900 Series	 08ESK	-	✓	-	✓	✓	-	-	✓	-	107
			10ESK	-	✓	-	✓	✓	-	-	✓	-	
			12ESK	-	✓	-	✓	✓	-	-	✓	-	
			14ESK	-	✓	-	✓	✓	-	-	✓	-	
			08ELK	-	✓	-	✓	✓	-	-	✓	-	
		1200 Series	 10ELK	-	✓	-	✓	✓	-	-	✓	-	108
12ELK			-	✓	-	✓	✓	-	-	✓	-		
14ELK			-	✓	-	✓	✓	-	-	✓	-		

Product	Series	Model	Remote Control	Regulator Control	Pull Switch	3-speed Selection	5-speed Selection	OFF Timer	Metal Blades	360° Oscillation	Page		
Ceiling Fan	Remote Control Series	 U56PR	✓	-	-	✓	-	✓	✓	-	111		
		Regulator Control Series	 T48XC	T48XC	-	✓	-	-	✓	-	✓	-	112
	T56XC			-	✓	-	-	✓	-	✓	-		
	 T48XG		T48XG	-	✓	-	-	✓	-	✓	-	113	
		T56XG	-	✓	-	-	✓	-	✓	-			
	 X48XC	X48XC	-	✓	-	-	✓	-	✓	-	114		
		X56XC	-	✓	-	-	✓	-	✓	-			
		 X48XG	X48XG	-	✓	-	-	✓	-	✓		-	115
			X56XG	-	✓	-	-	✓	-	✓		-	
		Orbital Fan	 M40R	-	✓	-	-	✓	-	✓		✓	116
	Electric Fan	Wall Fan	 M30C	M30C	-	-	✓	✓	-	-	-	117	
				M40C	-	-	✓	✓	-	✓	-		
			 M40M	✓	-	-	✓	-	✓	-	-	118	
		 YU50X	-	-	✓	✓	-	✓	✓	-	119		

Ceiling Mount Type Ventilation Fan



24CMUA / 24CMHA / 27CMHA

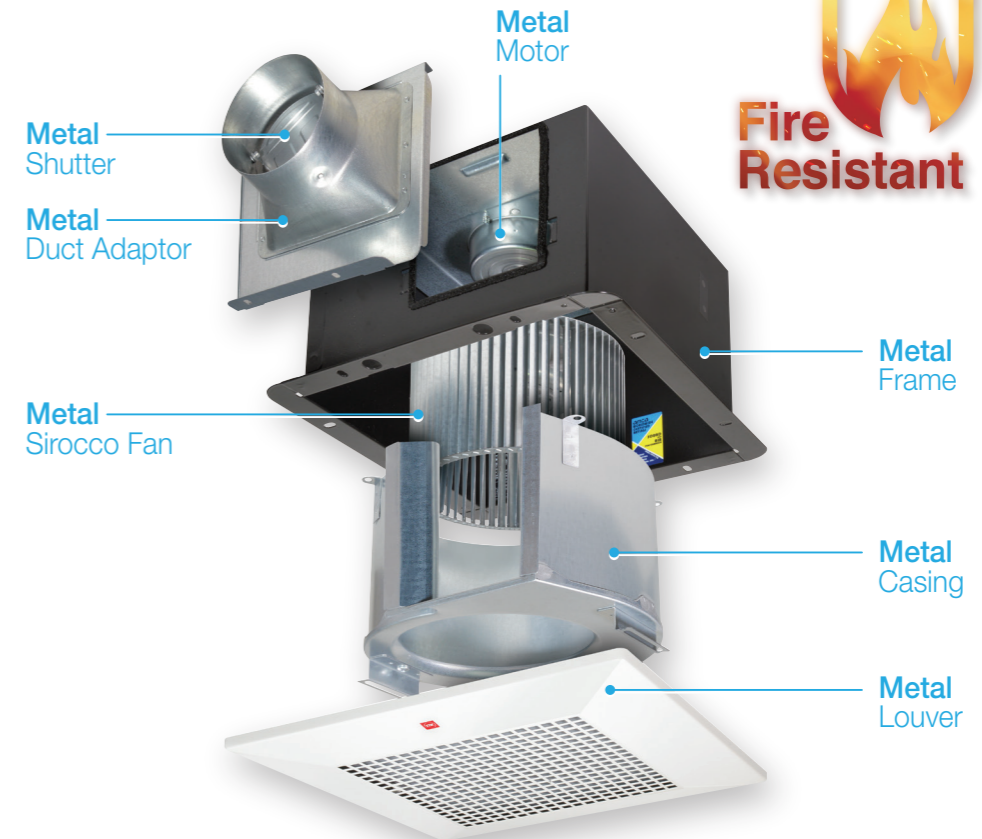

*Metallic structure can reduce the fire risk spread to other area from fire affected compartment through the ducting.

DC Motor Series

Usage: Bathroom Toilet Living Room / Corridor / Office / Retail Store

24JRB

24-Hour Ventilation

Installation 230 x 230mm

Duct Type Ø100mm



- DC (Direct Current) motor
- Auto operation by motion sensor
- Constant airflow
- Automated air volume adjustment
- Delay timer (15 minutes)
- Resonance-Noise-Absorption Structure
- Motor insulation Class E
- IP protection: IPX2

Dimension
Unit : mm

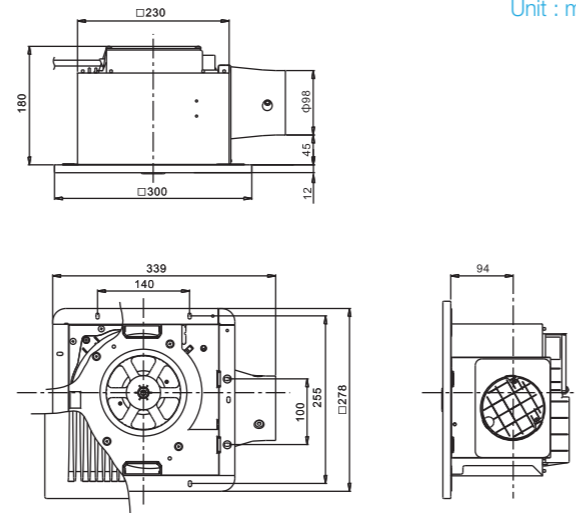

Specification

Model	Voltage [V]	Frequency [Hz]	Speed	Air Volume		Consumption [W]	RPM	Noise [dB(A)]	Weight [kg]	Installation Space [mm]	Duct Size [mm]
				[CMH]	[CFM]						
24JRB	220-240	60	Hi	160	94	8	742	31	2.9	240 x 240	Ø100
				120	71	5.2	556	26			
			Lo	80	47	3.6	441	20			
				Hi	160	94	8	742			
	220-230	50	Lo	120	71	5.2	556	26			
				80	47	3.6	441	20			

- Note:
- 1.The value of power consumption, air volume and noise are specified at the static pressure of 0 Pa.
 - 2.The value of air volume is the mean value which is measured by our company.
 - 3.The value of noise level is measured at 1m apart from the left, the right and the front of product, then get the average of three values.
 - 4.The value of noise level is A weight average sound pressure level, the mean value is measured by our company.

Installation Example

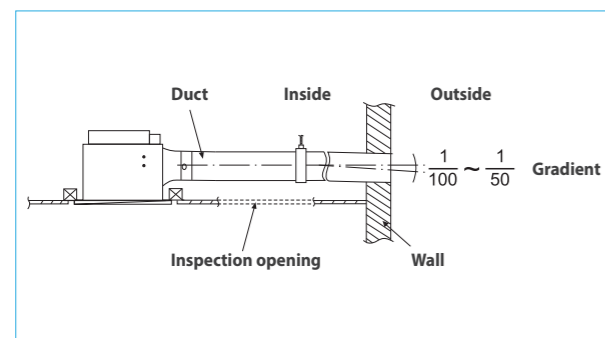

Wiring Diagram

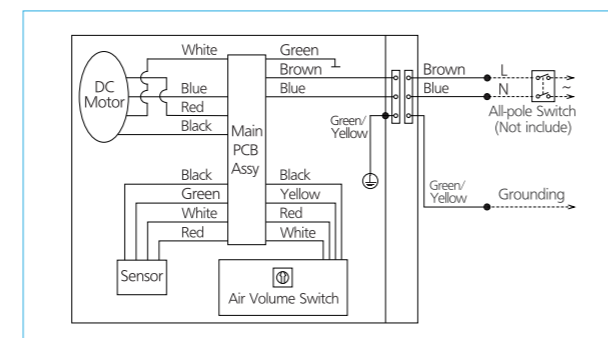

DC Motor Series

Usage: Bathroom Toilet Living Room / Corridor / Office / Retail Store

24JAB

24-Hour Ventilation

Installation 230 x 230mm

Duct Type Ø100mm



- DC (Direct Current) motor
- Constant airflow
- Automated air volume adjustment
- Delay timer (15 minutes)
- Resonance-Noise-Absorption Structure
- Motor insulation Class E
- IP protection: IPX2

Dimension
Unit : mm

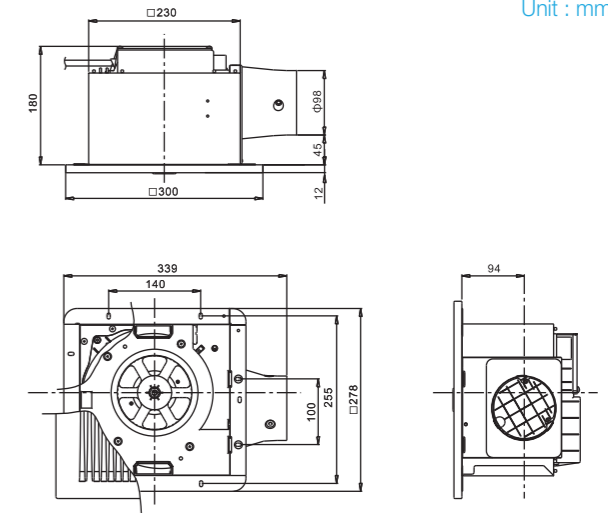

Specification

Model	Voltage [V]	Frequency [Hz]	Speed	Air Volume		Consumption [W]	RPM	Noise [dB(A)]	Weight [kg]	Installation Space [mm]	Duct Size [mm]
				[CMH]	[CFM]						
24JAB	220-240	60	Hi	160	94	8	742	31	2.9	240 x 240	Ø100
				120	71	5.2	556	26			
			Lo	80	47	3.6	441	20			
				Hi	160	94	8	742			
	220-230	50	Lo	120	71	5.2	556	26			
				80	47	3.6	441	20			

- Note:
- 1.The value of power consumption, air volume and noise are specified at the static pressure of 0 Pa.
 - 2.The value of air volume is the mean value which is measured by our company.
 - 3.The value of noise level is measured at 1m apart from the left, the right and the front of product, then get the average of three values.
 - 4.The value of noise level is A weight average sound pressure level, the mean value is measured by our company.

Installation Example

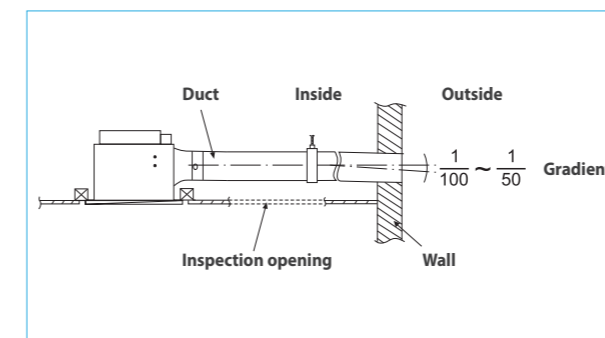

Wiring Diagram

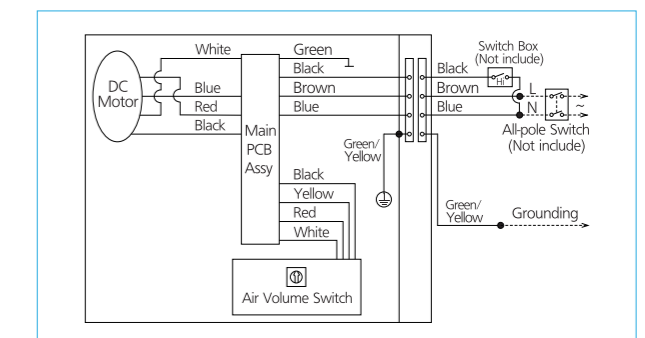

Super Quiet Series

Usage: Bathroom Toilet Living Room / Corridor / Office / Retail Store

17CUH

24-Hour Ventilation

Installation 170 x 170mm

Duct Type Ø100mm



Dimension

Unit : mm

A	B	C	D	E	F	G	Duct Size
214	194	84	164	170	240	20	Ø100

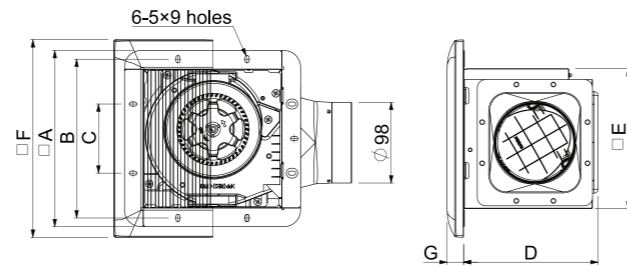

- Half pitch condenser motor with thermal cut-off
- Well-lubricated ball bearing for long life operation
- Effective control of air turbulence with taper blade
- Curve-shaped backdraft shutter
- Super low noise
- Motor insulation Class B
- IP protection: IPX2

Specification

Model	Voltage [V]	Frequency [Hz]	Air Volume		Consumption [W]	Noise [dB(A)]	Weight [kg]	Installation Space [mm]	Duct Size [mm]
			[CMH]	[CFM]					
17CUH	220	50	85	50	7.5	23	1.7	177 x 177	Ø100
		60	85	50	10	24			
		50	85	50	8.5	24.5			
	230	60	85	50	10	24			
		50	90	53	9.5	26			

Note:

- 1.The value of power consumption, air volume and noise are specified at the static pressure of 0 Pa.
- 2.The value of air volume is the mean value which is measured by our company.
- 3.The value of noise level is measured at 1m apart from the left, the right and the front of product, then get the average of three values.
- 4.The value of noise level is A weight average sound pressure level, the mean value is measured by our company.

Installation Example

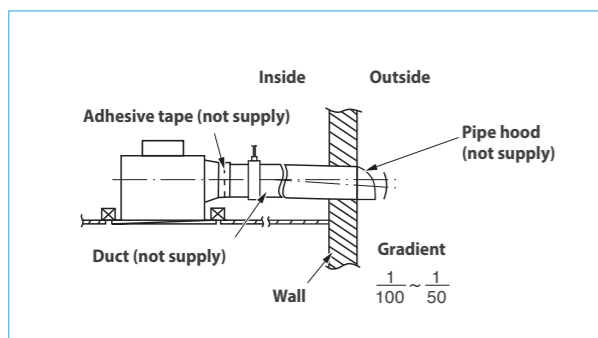

Wiring Diagram

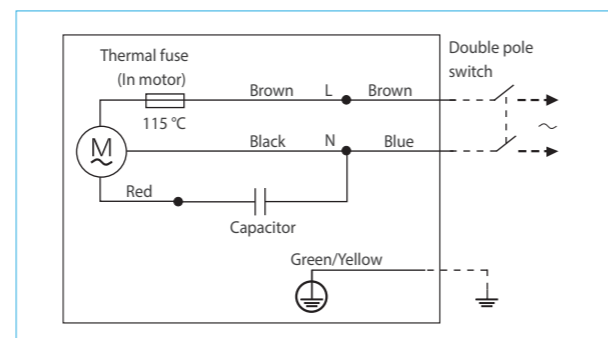

Super Quiet Series

Usage: Bathroom Toilet Living Room / Corridor / Office / Retail Store

24CUH / 24CDH / 24CHH

24-Hour Ventilation

Installation 233 x 233mm

Duct Type Ø100mm



Dimension

Unit : mm

A	B	C	D	E	F	G	Duct Size
278	255	140	175	233	300	13	Ø100

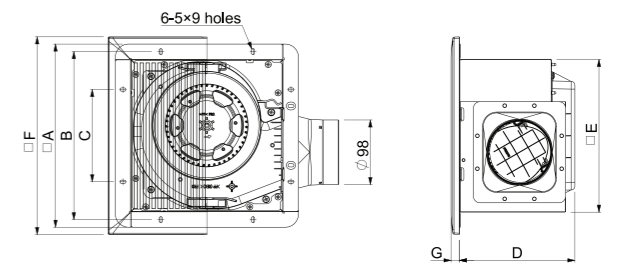

- Half pitch condenser motor with thermal cut-off
- Well-lubricated ball bearing for long life operation
- Effective control of air turbulence with taper blade
- Curve-shaped backdraft shutter
- Super low noise
- Motor insulation Class B
- IP protection: IPX2

Specification

Model	Voltage [V]	Frequency [Hz]	Air Volume		Consumption [W]	Noise [dB(A)]	Weight [kg]	Installation Space [mm]	Duct Size [mm]
			[CMH]	[CFM]					
24CUH	220	50	140	82	10.5	25	2.7	240 x 240	Ø100
		60	150	88	13.5	26.5			
		50	150	88	11	26			
	230	60	150	88	13.5	26.5			
		50	160	94	12	27			
		220	50	170	100	13.5			
24CDH	230	50	180	106	15	30	2.7	240 x 240	Ø100
		60	180	106	19	31			
		50	190	112	16.5	31.5			
	240	50	200	118	16.5	32			
		60	200	118	20.5	33.5			
		50	210	124	18	34			
24CHH	230	60	200	118	22.5	34	2.7	240 x 240	Ø100
		50	210	124	19.5	35			

Note:

- 1.The value of power consumption, air volume and noise are specified at the static pressure of 0 Pa.
- 2.The value of air volume is the mean value which is measured by our company.
- 3.The value of noise level is measured at 1m apart from the left, the right and the front of product, then get the average of three values.
- 4.The value of noise level is A weight average sound pressure level, the mean value is measured by our company.

Installation Example

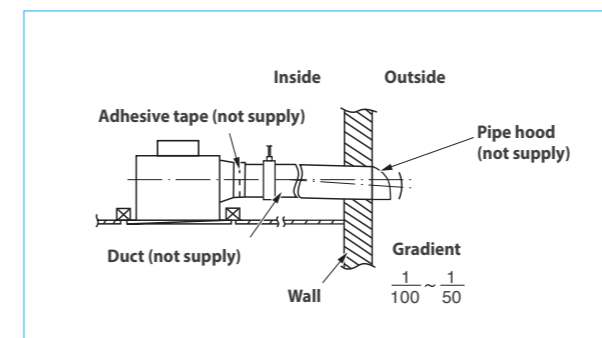

Wiring Diagram

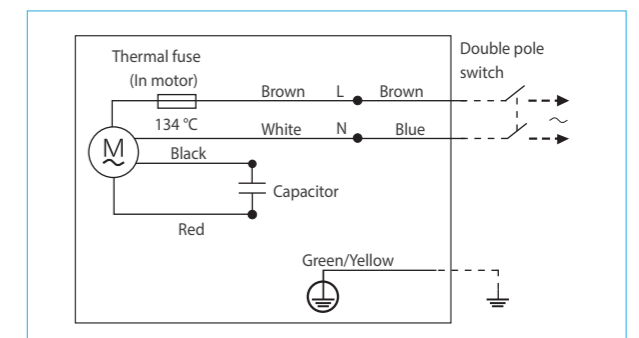

Super Quiet Series

Usage: Bathroom Toilet Living Room / Corridor / Office / Retail Store

24CXH

24-Hour Ventilation

Installation 233 x 233mm

Duct Type Ø100mm



Dimension

Unit : mm

A	B	C	D	E	F	G	Duct Size
278	255	140	175	233	300	13	Ø100

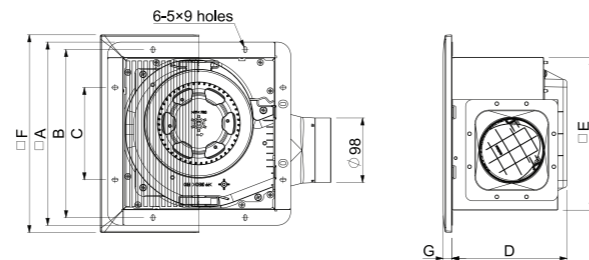

- Half pitch condenser motor with thermal cut-off
- Well-lubricated ball bearing for long life operation
- Effective control of air turbulence with taper blade
- Curve-shaped backdraft shutter
- Super low noise
- Motor insulation Class B
- IP protection: IPX2

Specification

Model	Voltage [V]	Frequency [Hz]	Air Volume		Consumption [W]	Noise [dB(A)]	Weight [kg]	Installation Space [mm]	Duct Size [mm]
			[CMH]	[CFM]					
24CXH	220	50	235	138	24	38	2.7	240 x 240	Ø100
		60	255	150	29	40			
	230	50	240	141	26.5	39			
	240	50	250	147	29	40			

Note:

- 1.The value of power consumption, air volume and noise are specified at the static pressure of 0 Pa.
- 2.The value of air volume is the mean value which is measured by our company.
- 3.The value of noise level is measured at 1m apart from the left, the right and the front of product, then get the average of three values.
- 4.The value of noise level is A weight average sound pressure level, the mean value is measured by our company.

Installation Example

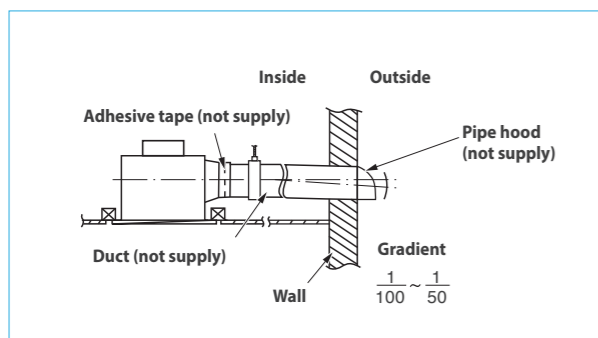

Wiring Diagram

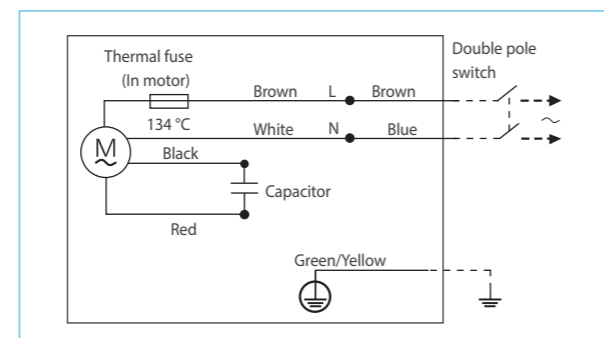

Super Quiet Series

Usage: Bathroom Toilet Living Room / Corridor / Office / Retail Store

27CHH

24-Hour Ventilation

Installation 260 x 260mm

Duct Type Ø150mm



Dimension

Unit : mm

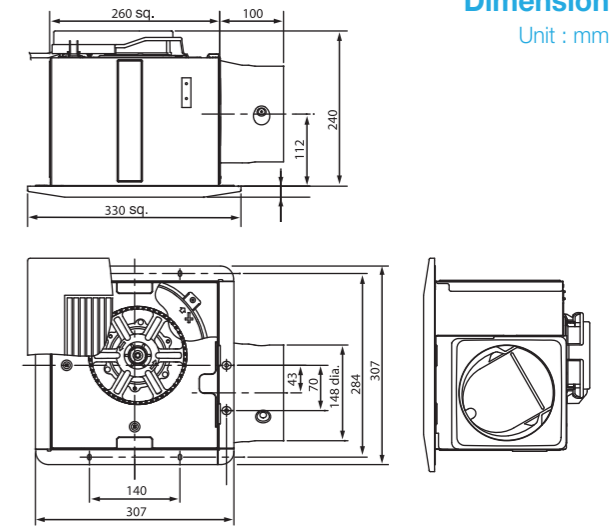

- Super low noise
- Long life ball bearing motor
- Effective control of air turbulence with taper blade
- Resonance-Noise-Absorption Structure
- Pre-installed power cord
- 2 speed selectable
- Motor insulation Class E
- IP protection: IPX2

Specification

Model	Voltage [V]	Frequency [Hz]	Air Volume		Consumption [W]	Noise [dB(A)]	Weight [kg]	Installation Space [mm]	Duct Size [mm]	
			[CMH]	[CFM]						
27CHH	220	50	Hi	330	194	28	34	4.4	270 x 270	Ø150
			Lo	260	153	23	30			
		60	Hi	330	194	33	34			
			Lo	270	159	26	31			
	230	50	Hi	340	200	31.5	35			
			Lo	275	162	25.5	31.5			
		60	Hi	360	212	34	36.5			
			Lo	290	171	27.5	32			

Note:

- 1.The value of power consumption, air volume and noise are specified at the static pressure of 0 Pa.
- 2.The value of air volume is the mean value which is measured by our company.
- 3.The value of noise level is measured at 1m apart from the left, the right and the front of product, then get the average of three values.
- 4.The value of noise level is A weight average sound pressure level, the mean value is measured by our company.

Installation Example

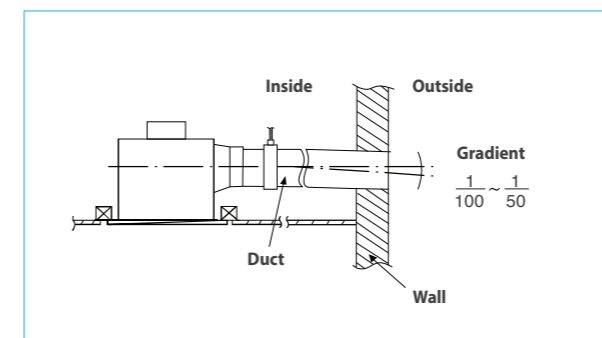

Wiring Diagram

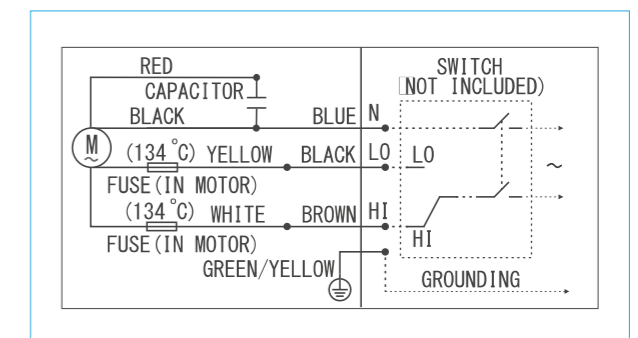

Super Quiet Series

Usage: Bathroom Toilet Living Room / Corridor / Office / Retail Store

32CDH

24-Hour Ventilation

Installation 310 x 310mm

Duct Type Ø150mm

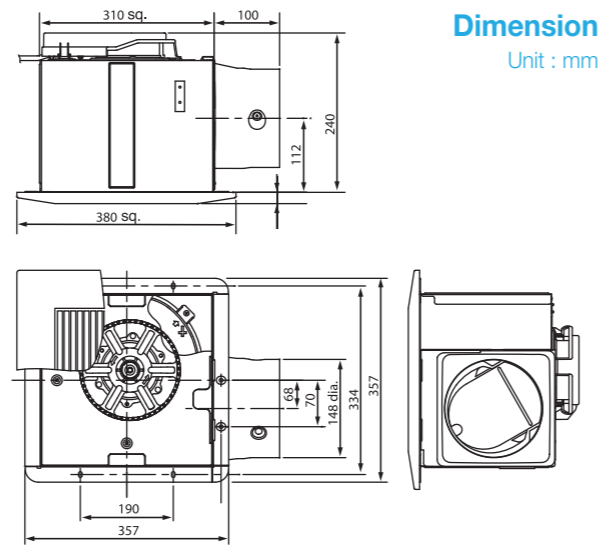

- Half pitch condenser motor with thermal cut-off
- Well-lubricated ball bearing for long life operation
- Effective control of air turbulence with taper blade
- Curve-shaped backdraft shutter
- Super low noise
- Motor insulation Class E
- IP protection: IPX2

Specification

Model	Voltage [V]	Frequency [Hz]	Air Volume		Consumption [W]	Noise [dB(A)]	Weight [kg]	Installation Space [mm]	Duct Size [mm]	
			[CMH]	[CFM]						
32CDH	220	50	Hi	430	253	42	5.2	320 x 320	Ø150	
			Lo	300	177	32				
		60	Hi	410	241	48				35.5
			Lo	285	168	33				27.5
	230	50	Hi	440	259	46				37.5
			Lo	315	185	34				29
		60	Hi	470	277	50				38.5
			Lo	330	194	38				30

- Note:
- 1.The value of power consumption, air volume and noise are specified at the static pressure of 0 Pa.
 - 2.The value of air volume is the mean value which is measured by our company.
 - 3.The value of noise level is measured at 1m apart from the left, the right and the front of product, then get the average of three values.
 - 4.The value of noise level is A weight average sound pressure level, the mean value is measured by our company.

Installation Example

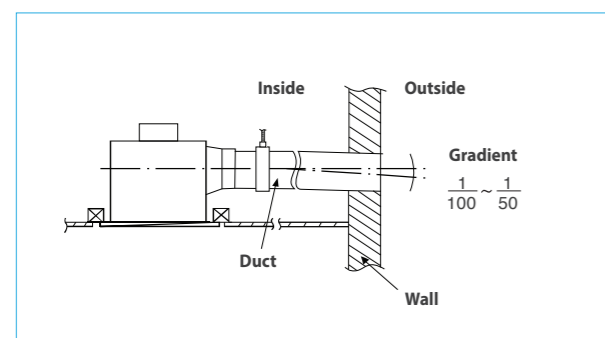

Wiring Diagram

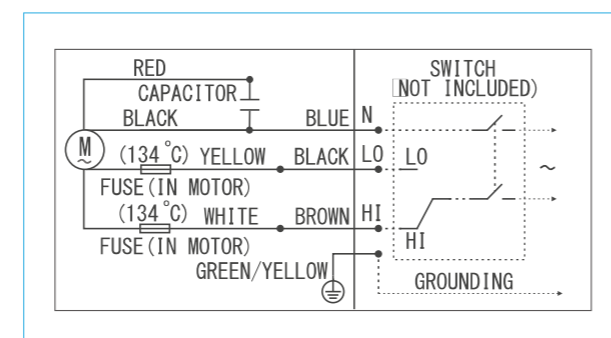

Standard Series

Usage: Bathroom Toilet Living Room / Corridor / Office / Retail Store

38CDG / 38CDG 05

24-Hour Ventilation

Installation 375 x 375mm

Duct Type Ø150mm

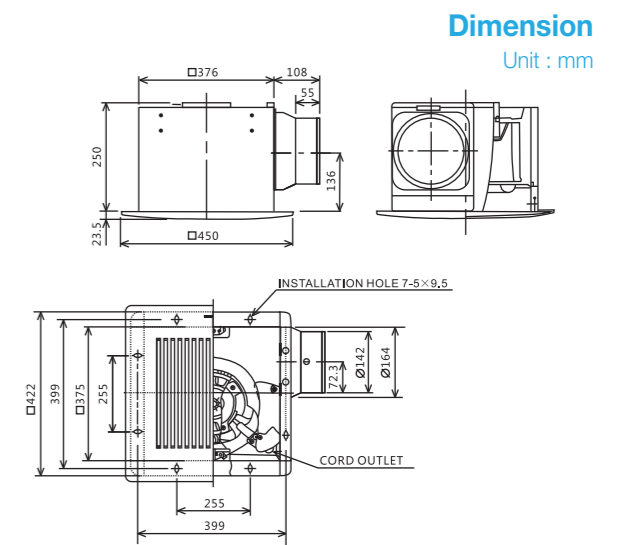

- High-Low speed selectable
- Condenser motor with thermal cut-off
- Well-lubricated ball bearing for long life operation
- High performance sirocco fan
- Motor insulation Class E

Specification

Model	Voltage [V]	Frequency [Hz]	Air Volume		Consumption [W]	Noise [dB(A)]	Weight [kg]	Installation Space [mm]	Duct Size [mm]	
			[CMH]	[CFM]						
38CDG 38CDG 05	220	50	Hi	640	377	90	9.7	385 x 385	Ø150	
			Lo	430	253	66				35
		60	Hi	630	371	98				43.5
			Lo	410	241	66.4				34.5
	230	50	Hi	675	397	96				46
			Lo	440	259	72				36
		60	Hi	700	412	104				47
			Lo	470	277	78				37

- Note:
- 1.The value of power consumption, air volume and noise are specified at the static pressure of 0 Pa.
 - 2.The value of air volume is the mean value which is measured by our company.
 - 3.The value of noise level is measured at 1m apart from the left, the right and the front of product, then get the average of three values.
 - 4.The value of noise level is A weight average sound pressure level, the mean value is measured by our company.

Installation Example

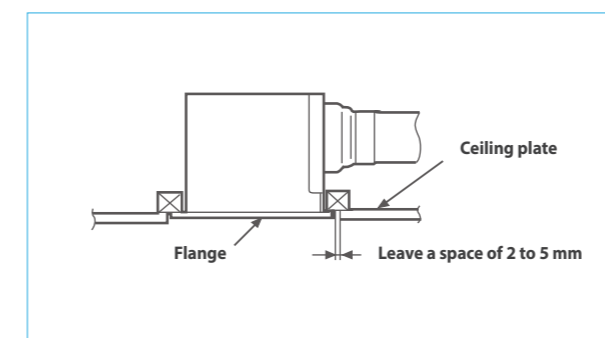

Wiring Diagram

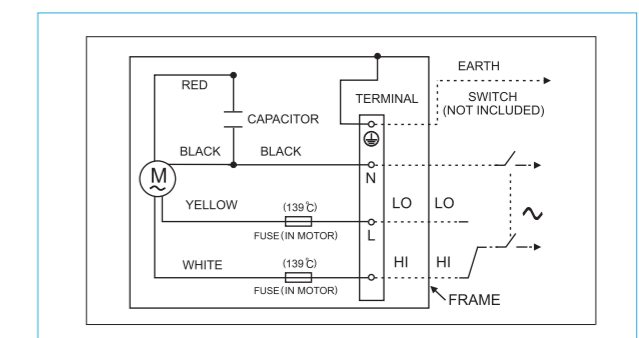

Standard Series

Usage: Bathroom Toilet Living Room / Corridor / Office / Retail Store

38CHG

24-Hour Ventilation

Installation 375 x 375mm

Duct Type Ø150mm



- Condenser motor with thermal cut-off
- Well-lubricated ball bearing for long life operation
- Effective control of air turbulence with taper blade
- Reverse flow prevention shutter
- 2 speed selectable
- Motor insulation Class E
- IP protection: IPX2

Dimension
Unit : mm

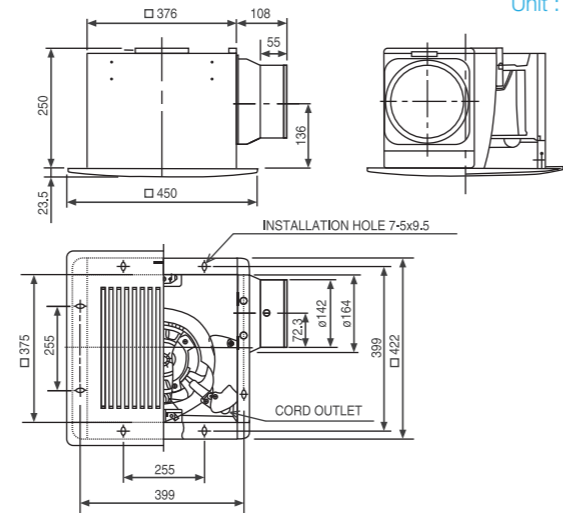

Specification

Model	Voltage [V]	Frequency [Hz]	Air Volume		Consumption [W]	RPM	Noise [dB(A)]	Weight [kg]	Installation Space [mm]	Duct Size [mm]
			[CMH]	[CFM]						
38CHG	220	50	Hi	800	471	122	790	49.5	385 x 385	Ø150
			Lo	525	309	89	540	39.5		
		60	Hi	790	465	138	760	49		
			Lo	500	294	90	509	39		
	230	50	Hi	800	471	122	775	49		
			Lo	470	277	84	485	37		
		50	Hi	835	491	132	807	50		
			Lo	490	288	90	504	38		

Note: RPM data is for reference only, values may vary subject to different conditions

Test Condition

- Air volume, electric characteristic and noise are specified at the static pressure of 0 Pa
- The values of noise level is A weighted average sound pressure level, the mean values are measured by our company, within +3 to -7 dB tolerance
- The values of noise level are measured at 1 m apart from the side of fan body when ducts are connected on outlet side
- The values of air volume are the mid-points of results measured by our company, within ±10% tolerance

Installation Example

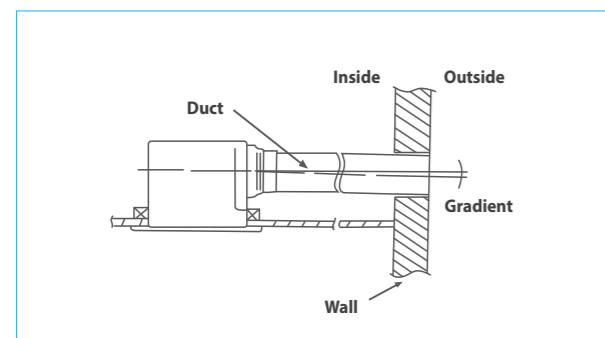

Wiring Diagram

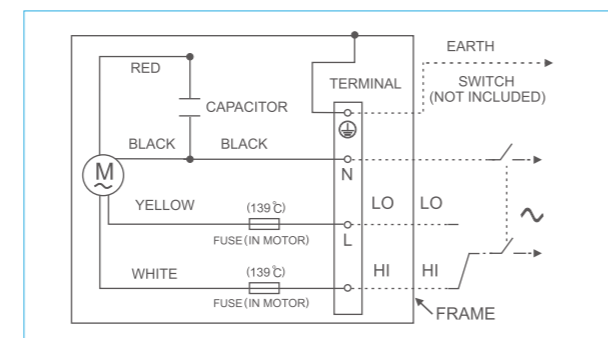

Metal Series

Usage: Bathroom Toilet Living Room / Corridor / Office / Retail Store

24CMUA / 24CMHA

Fire Resistant

24-Hour Ventilation

Installation 240 x 240mm

Duct Type Ø100mm



- All-metal structure design
- Well-lubricated ball bearing for long life operation
- Metallic components to improve fire resistance
- Reverse flow prevention shutter
- Motor insulation Class E
- IP protection: IPX2

Dimension
Unit : mm

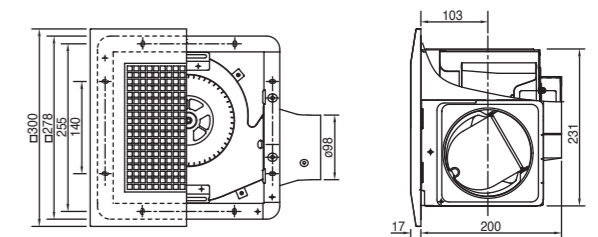

Specification

Model	Voltage [V]	Frequency [Hz]	Air Volume		Consumption [W]	Noise [dB(A)]	Weight [kg]	Installation Space [mm]	Duct Size [mm]
			[CMH]	[CFM]					
24CMUA	220	50	90	53	11	25	3.9	240 x 240	Ø100
			100	59	12	26			
		60	95	56	12	25.5			
			100	59	13	26			
24CMHA	220	50	180	106	20	37	3.9	240 x 240	Ø100
			180	106	23	37			
		60	190	112	22	37.5			
			200	118	25	38			

Note:

1. The value of power consumption, air volume and noise are specified at the static pressure of 0 Pa.
2. The value of air volume is the mean value which is measured by our company.
3. The value of noise level is measured at 1m apart from the left, the right and the front of product, then get the average of three values.
4. The value of noise level is A weight average sound pressure level, the mean value is measured by our company.

Installation Example

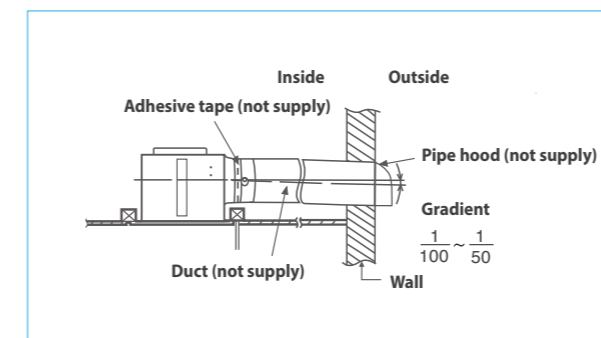

Wiring Diagram

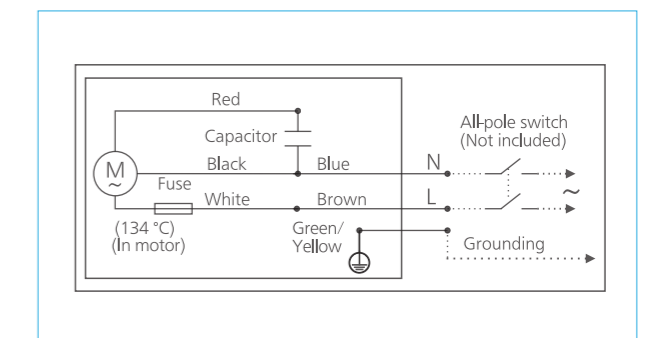

Metal Series

Usage: Bathroom Toilet Living Room / Corridor / Office / Retail Store

27CMHA

- Fire Resistant**
- 24-Hour Ventilation**
- Installation 270 x 270mm
- Duct Type Ø148mm

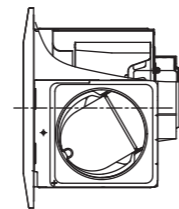
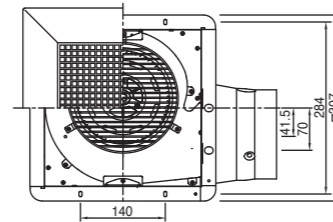
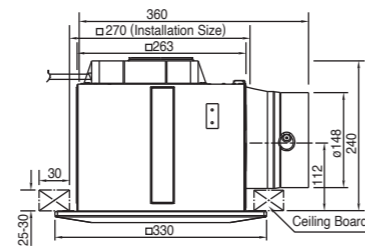

Dimension
Unit : mm

- All-metal structure design
- Well-lubricated ball bearing for long life operation
- Metallic components within air stream provides extra safety against fire
- Reverse flow prevention shutter
- Motor insulation Class E
- IP protection: IPX2

Specification

Model	Voltage [V]	Frequency [Hz]	Air Volume		Consumption [W]	Noise [dB(A)]	Weight [kg]	Intallation Space [mm]	Duct Size [mm]
			[CMH]	[CFM]					
27CMHA	220	50	360	212	35	37	5.9	270 x 270	Ø150
		60	380	224	43	37.5			
	230	50	380	224	38	37.5			
		50	400	235	43	38			

- Note:
- 1.The value of power consumption, air volume and noise are specified at the static pressure of 0 Pa.
 - 2.The value of air volume is the mean value which is measured by our company.
 - 3.The value of noise level is measured at 1m apart from the left, the right and the front of product, then get the average of three values.
 - 4.The value of noise level is A weight average sound pressure level, the mean value is measured by our company.

Installation Example

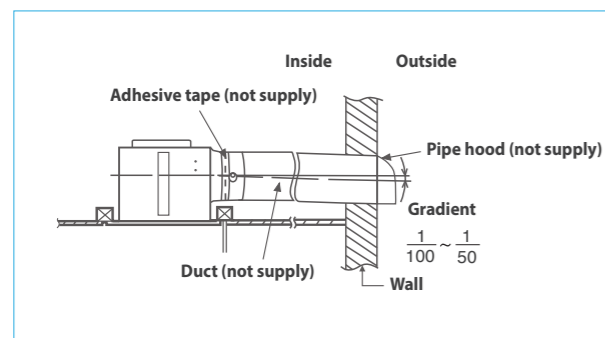

Wiring Diagram

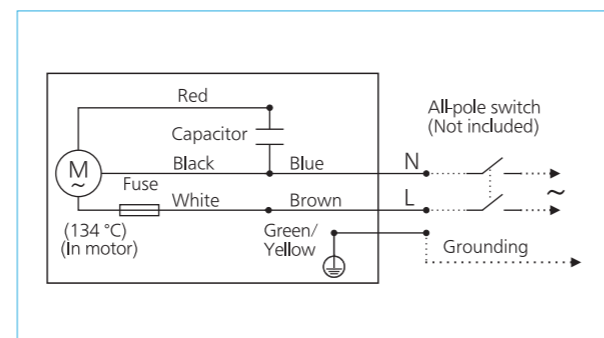

Wall Mount Type Ventilation Fan



24-Hour Ventilation



Contemporary



Safe



Low-noise



Scan for more information



Features

Smart Design

The new flat design creates a feeling of floating upon installation on wall. Meanwhile, slim louver is designed for the louver series. Such minimalistic elements integrate seamlessly with the interior space.

Only applicable for model:
20AUA/25AUA/30AUA
20ALA/25ALA/30ALA

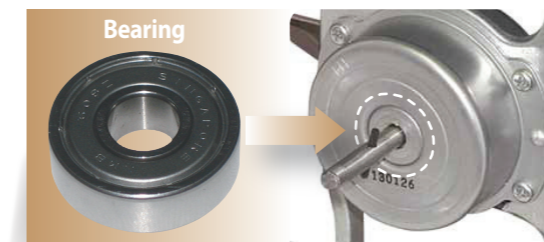

Half Pitch Motor & Bearing

All models adopt half pitch capacitor induction motor and long life bearing that prolongs the product durability, with average 30,000 hours life. They also enable energy saving by reducing power consumption down to average 13%.

Thermal Fuse Equipped

All motors are equipped with thermal fuses which would stop when they are overheated. It can prevent further temperature rise and minimize the risk of fire hazard.



Silent Stream Fan

Silent Stream Fan

New Blade design applies advanced aerodynamic principle that optimizes the blade shape.

Only applicable for model:
20AUA/25AUA/30AUA
20ALA/25ALA/30ALA



3D Sickle Blade

New Blade design adopts an increased blade size and airfoil curve optimization. It can increase the air volume by the adjusted blade shape which can match the airflow. Furthermore, it can lower the noise by evening the airflow velocity with the silent wing.

*Features above are only applicable to some of the models

Metallic Series

Usage: Bathroom Toilet Office / Retail Store

20ASB / 25ASB / 30ASB
20ASB 05 / 25ASB 05 / 30ASB 05

Dimension
Unit : mm

Metallic Structure

20 Series Installation 240 x 240mm

25 Series Installation 290 x 290mm

30 Series Installation 340 x 340mm



Model	A	B	C	D	E	F
20ASB/20ASB 05	200	300	312	240	50	90
25ASB/25ASB 05	250	350	362	290	45	90
30ASB/30ASB 05	300	400	412	340	45	90

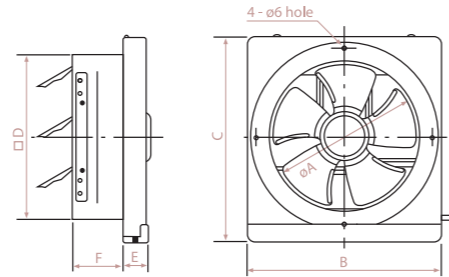

- Condenser motor with thermal cut-off
- Well-lubricated ball bearing for long life operation
- High performance propeller fan adopted
- Automatic shutter
- Powder painted metallic orifice, blade and oil cup
- Detachable oil cup
- Motor insulation Class E
- IP protection: IPX4 (outside)

Specification

Model	Voltage [V]	Frequency [Hz]	Air Volume		Consumption [W]	Noise [dB(A)]	Weight [kg]	Installation Space [mm]
			[CMH]	[CFM]				
20ASB 20ASB 05	220	50	516	304	17	37.5	3.3	250 x 250
		60	612	360	21.5	40.6		
	230	50	528	311	18.1	38.1		
25ASB 25ASB 05	220	50	858	505	25	39.1	3.8	300 x 300
		60	954	562	30.5	40.6		
	230	50	864	509	27.3	39.3		
30ASB 30ASB 05	220	50	1,182	696	29.5	39.2	4.4	350 x 350
		60	1,164	685	34.5	39		
	230	50	1,248	735	31.7	40.6		
	240	50	1,290	759	34	41.3		

- Note:
- 1.The value of power consumption, air volume and noise are specified at the static pressure of 0 Pa.
 - 2.The value of air volume is the mean value which is measured by our company.
 - 3.The value of noise level is measured at 1m apart from the left, the right and the front of product, then get the average of three values.
 - 4.The value of noise level is A weight average sound pressure level, the mean value is measured by our company.

Installation

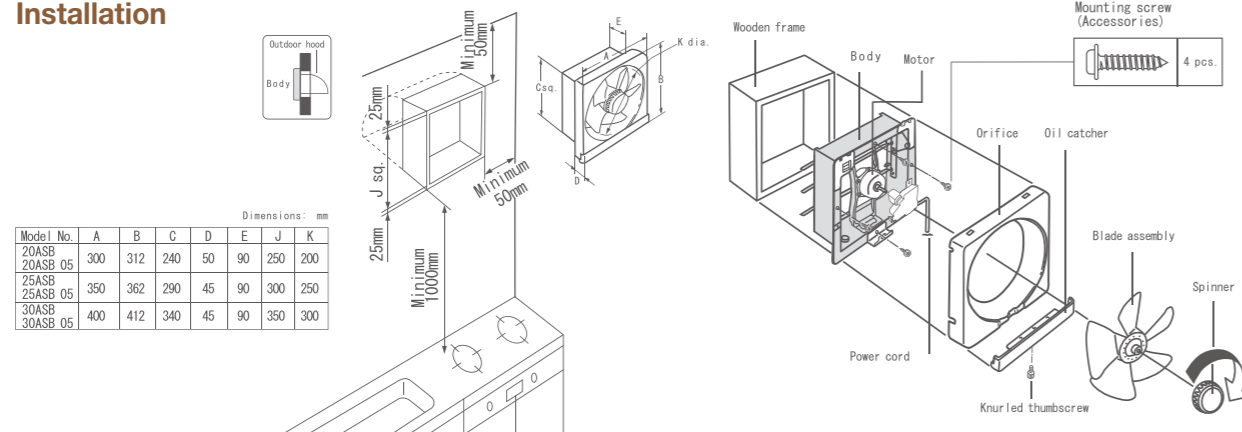

Model No.	A	B	C	D	E	J	K
20ASB 20ASB 05	300	312	240	50	90	250	200
25ASB 25ASB 05	350	362	290	45	90	300	250
30ASB 30ASB 05	400	412	340	45	90	350	300

Automatic Shutter Series

Usage: Bathroom Toilet Office / Retail Store

15AAQ1

Dimension
Unit : mm

Metallic Structure

Orifice Equipped with Oil Cup

Installation 170 x 170mm

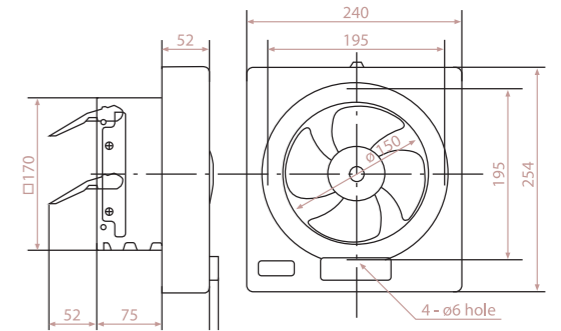

- Condenser motor with thermal cut-off
- Well-lubricated ball bearing for long life operation
- High performance propeller fan adopted
- Automatic shutter with plastic cushions
- Orifice equipped with oil cup
- Motor insulation Class E
- IP protection: IPX4 (outside)

Specification

Model	Voltage [V]	Frequency [Hz]	Air Volume		Consumption [W]	Noise [dB(A)]	Weight [kg]	Installation Space [mm]
			[CMH]	[CFM]				
15AAQ1	220	50	288	170	15	31	1.4	175 x 175
		60	306	180	19	34		
	230	50	294	173	17	33		
		240	50	306	180	19		

- Note:
- 1.The value of power consumption, air volume and noise are specified at the static pressure of 0 Pa.
 - 2.The value of air volume is the mean value which is measured by our company.
 - 3.The value of noise level is measured at 1m apart from the left, the right and the front of product, then get the average of three values.
 - 4.The value of noise level is A weight average sound pressure level, the mean value is measured by our company.

Installation

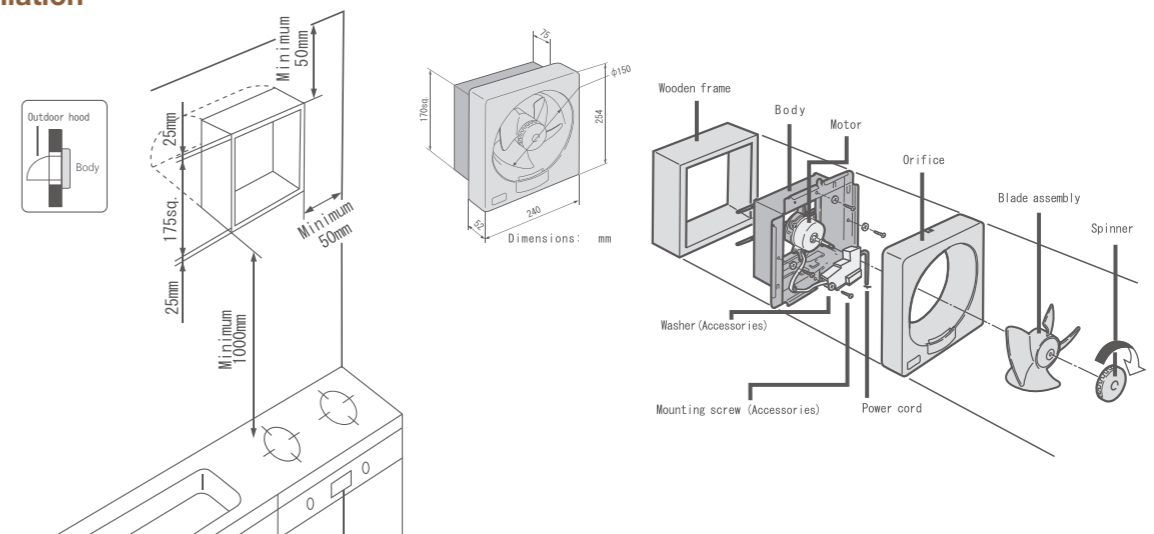

Automatic Shutter Series

Usage: Bathroom Toilet Office / Retail Store

20AUA / 25AUA / 30AUA

Dimension
Unit : mm

- Silent Stream Fan
- Flat Surface Design
- Automatic Shutter

Model	A	B	C	D	E	F	G
20AUA	223	302	302	240	30	90	85
25AUA	273	352	352	290	32	90	67
30AUA	317	402	402	340	32	90	83

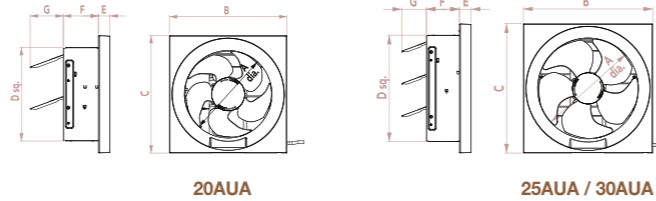

- Flat surface design
- Silent stream fan
- Half pitch condenser motor with thermal cut-off
- Well-lubricated ball bearing for long life operation
- Automatic shutter
- Motor insulation Class B
- IP protection: IPX4 (outside)

Specification

Model	Voltage [V]	Frequency [Hz]	Air Volume		Consumption [W]	Noise [dB(A)]	Weight [kg]	Installation Space [mm]
			[CMH]	[CFM]				
20AUA	220-230	50	590-610	347-359	18-19.5	36-36.5	1.9	250 x 250
	220-240	50	590-620	347-365	18-21.5	36-37		
	220	60	680	400	22	39		
	230	60	710	418	23.5	40		
25AUA	220-230	50	950-970	559-571	25-27	38-38.5	2.3	300 x 300
	220-240	50	950-990	559-571	25-27	38-39		
	220	60	990	571	31	39		
	230	60	1,040	612	35	41		
30AUA	220-230	50	1,200-1,250	706-736	28-30	37-38	2.6	350 x 350
	220-240	50	1,200-1,300	706-765	28-32.5	37-38		
	220	60	1,200	706	33	37		
	230	60	1,300	765	36	39		

- Note:
- The value of power consumption, air volume and noise are specified at the static pressure of 0 Pa.
 - The value of air volume is the mean value which is measured by our company.
 - The value of noise level is measured at 1m apart from the left, the right and the front of product, then get the average of three values.
 - The value of noise level is A weight average sound pressure level, the mean value is measured by our company.

Wiring Diagram

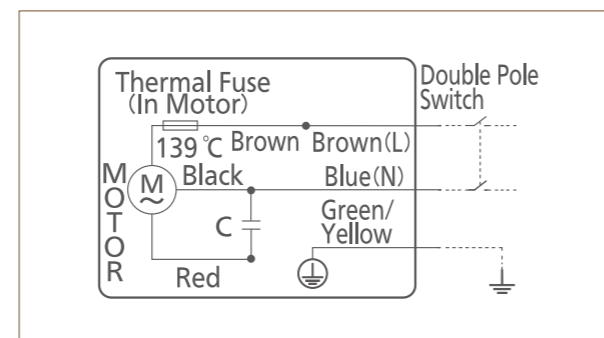

Automatic Shutter Series

Usage: Bathroom Toilet Office / Retail Store

20AUH / 25AUH / 30AUH 11

Dimension
Unit : mm

- Advanced Blade Design
- Automatic Shutter
- Single Speed

Model	A	B	C	D	E	F	G	H
20AUH	200	306	260	302	240	52	90	80
25AUH	250	356	310	352	290	38	90	63
30AUH 11	300	406	360	402	340	38	90	78

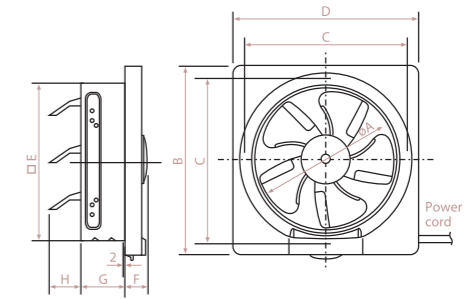

- Half pitch condenser motor with thermal cut-off
- Well-lubricated ball bearing for long life operation
- Propeller fan incorporated with advanced blade design (except 30AUH 11)
- Automatic shutter
- Motor insulation Class E
- IP protection: IPX4 (outside)

Specification

Model	Voltage [V]	Frequency [Hz]	Air Volume		Consumption [W]	Noise [dB(A)]	Weight [kg]	Installation Space [mm]
			[CMH]	[CFM]				
20AUH	220	50	580	341	22	38	2.0	250 x 250
		60	650	383	29	42		
25AUH	220	50	920	541	29	39	2.4	300 x 300
		60	940	553	33	39		
30AUH 11	220	50	1,200	706	29	39	2.7	350 x 350
		60	1,140	671	33	38		

- Note:
- The value of power consumption, air volume and noise are specified at the static pressure of 0 Pa.
 - The value of air volume is the mean value which is measured by our company.
 - The value of noise level is measured at 1m apart from the left, the right and the front of product, then get the average of three values.
 - The value of noise level is A weight average sound pressure level, the mean value is measured by our company.

Wiring Diagram

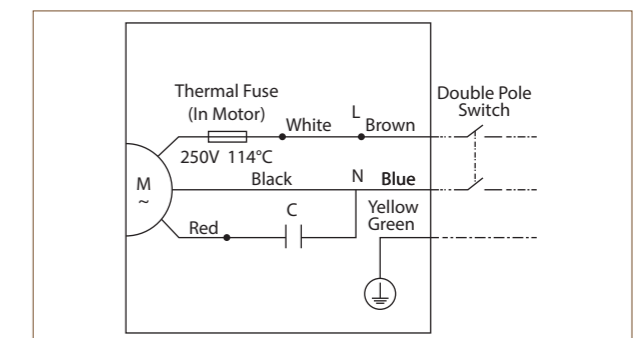

Automatic Shutter Louver Series

Usage: Bathroom Toilet Office / Retail Store

20ALA / 25ALA / 30ALA

Dimension
Unit : mm

Louver for Safety Protection

Silent Stream Fan

Automatic Shutter

Model	A	B	C	D	E	F	G
20ALA	223	302	302	240	60	90	85
25ALA	273	352	352	290	62	90	67
30ALA	317	402	402	340	62	90	83

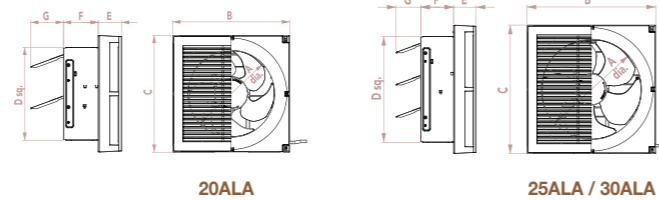

- Slim louver design
- Silent stream fan
- Half pitch condenser motor with thermal cut-off
- Well-lubricated ball bearing for long life operation
- Automatic shutter
- Motor insulation Class B
- IP protection: IPX4 (outside)

Specification

Model	Voltage [V]	Frequency [Hz]	Air Volume		Consumption [W]	Noise [dB(A)]	Weight [kg]	Installation Space [mm]
			[CMH]	[CFM]				
20ALA	220-230	50	550-555	324-327	18-19.5	38-38.5	2.0	250 x 250
	220-240	50	550-560	324-330	18-21.5	38-39		
	220	60	610	359	22	42.5		
	230	60	630	371	23.5	44		
25ALA	220-230	50	840-860	494-506	25-27	40.5-42	2.5	300 x 300
	220-240	50	840-880	494-518	25-30	40.5-43		
	220	60	860	506	31	42		
	230	60	910	536	34	45		
30ALA	220-230	50	1,000-1050	589-618	28-30	39-40	2.9	350 x 350
	220-240	50	1,000-1,100	589-647	28-32.5	39-41		
	220	60	1,000	589	33	40		
	230	60	1,050	618	36	41		

- Note:
- 1.The value of power consumption, air volume and noise are specified at the static pressure of 0 Pa.
 - 2.The value of air volume is the mean value which is measured by our company.
 - 3.The value of noise level is measured at 1m apart from the left, the right and the front of product, then get the average of three values.
 - 4.The value of noise level is A weight average sound pressure level, the mean value is measured by our company.

Wiring Diagram

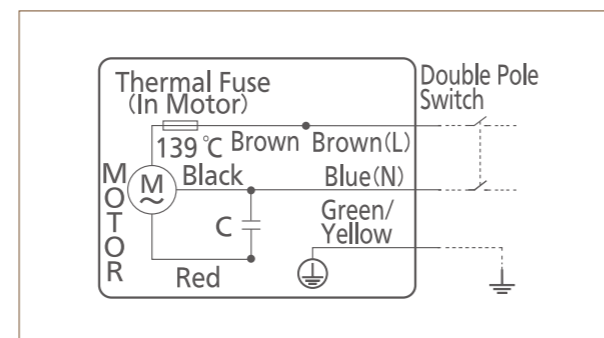

Automatic Shutter Louver Series

Usage: Bathroom Toilet Office / Retail Store

20ALH / 25ALH / 30ALF 11

Dimension
Unit : mm

Louver for Safety Protection

Advanced Blade Design

Single Speed

Model	A	B	C	D	E	F	G	H
20ALH	200	306	260	302	240	68	90	80
25ALH	250	356	310	352	290	63	90	63
30ALF 11	300	406	360	402	340	63	90	78

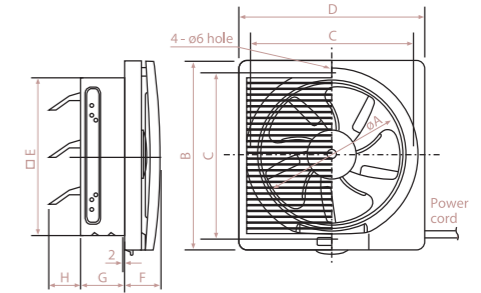

- Half pitch condenser motor with thermal cut-off
- Well-lubricated ball bearing for long life operation
- Propeller fan incorporated with advanced blade design (except 30ALF 11)
- Automatic shutter
- Motor insulation Class E
- IP protection: IPX4 (outside)

Specification

Model	Voltage [V]	Frequency [Hz]	Air Volume		Consumption [W]	Noise [dB(A)]	Weight [kg]	Installation Space [mm]
			[CMH]	[CFM]				
20ALH	220	50	546	321	22	40	2.2	250 x 250
		60	600	353	29	44		
25ALH	220	50	835	491	29	43	2.7	300 x 300
		60	846	498	33	43		
30ALF 11	220	50	935	550	29	43	3.1	350 x 350
		60	915	539	33	43		

- Note:
- 1.The value of power consumption, air volume and noise are specified at the static pressure of 0 Pa.
 - 2.The value of air volume is the mean value which is measured by our company.
 - 3.The value of noise level is measured at 1m apart from the left, the right and the front of product, then get the average of three values.
 - 4.The value of noise level is A weight average sound pressure level, the mean value is measured by our company.

Wiring Diagram

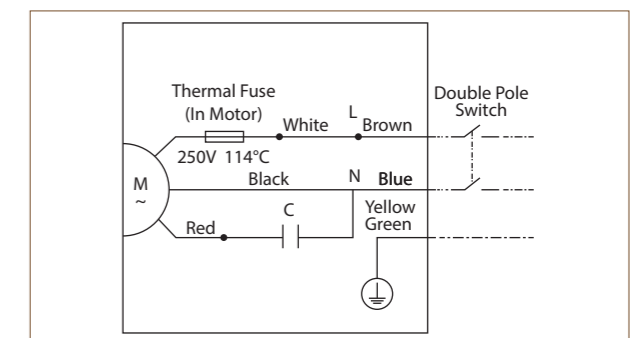

Automatic Shutter Louver Series

Usage: Bathroom Toilet Office / Retail Store

10BAQ1

- Powerful Sirocco Fan
- Louver for Safety Protection
- Long Life Operation



- Condenser motor with thermal cut-off
- Lubricated sintered brush for long life operation
- Highly efficient sirocco fan
- Blind shutter louver to enhance privacy and safety
- Plastic frame, blade and louver
- Motor insulation Class E
- IP protection: IPX4 (outside)

Dimension

Unit : mm

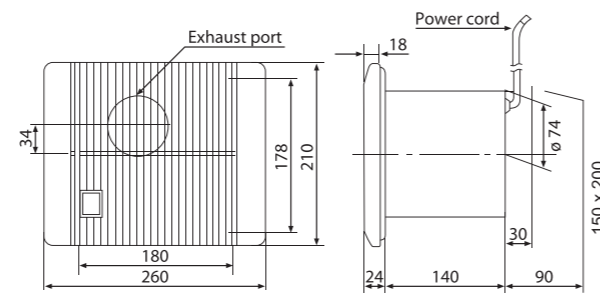

Specification

Model	Voltage [V]	Frequency [Hz]	Air Volume		Consumption [W]	RPM	Noise [dB(A)]	Weight [kg]	Installation Space [mm]
			[CMH]	[CFM]					
10BAQ1	220	50	76.3	45	15	1,250	40.1	1.7	155 x 205
		60	72.9	43	17	1,200	39.8		
	230	50	80.3	47	16	1,300	41.2		
		50	84.9	50	17.5	1,385	42		

Note: RPM data is for reference only, values may vary subject to different conditions

Test Condition

- Air volume, electric characteristic and noise are specified at the static pressure of 0 Pa
- The values of noise level is A weighted average sound pressure level, the mean values are measured by our company, within +3 to -7 dB tolerance
- The values of noise level are measured at 1 m apart from the side of fan body when ducts are connected on outlet side
- The values of air volume are the mid-points of results measured by our company, within ±10% tolerance

Installation

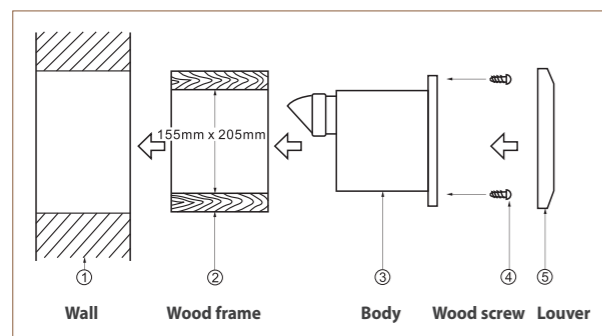

Wiring Diagram

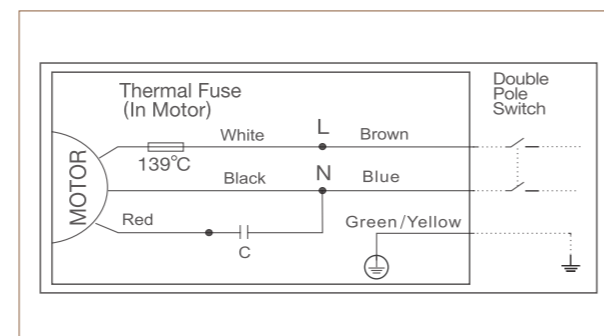

Feature of Bathroom Series

Easy Installation - Pipe Hood Series

With the supplied accessories, it only takes a few steps to complete the installation.

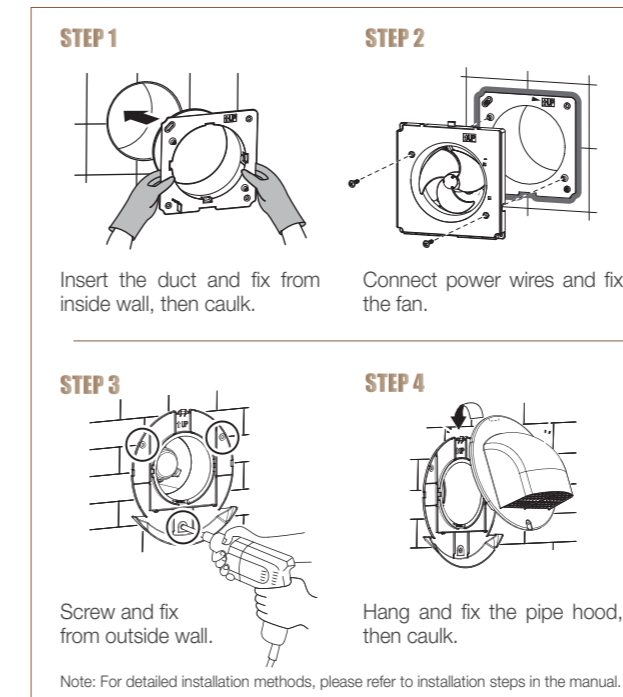

All Accessories Included

The product comes bundled with all required accessories. It conveniently saves the hassle of seeking necessary accessories around.



Trace-prevention

Pipe Hood Series Only

When it rains, rainwater dripping along the side of pipe hood may cause trace marks on wall. The exclusively designed duct ring catches and drains the water away to avoid forming trace marks.

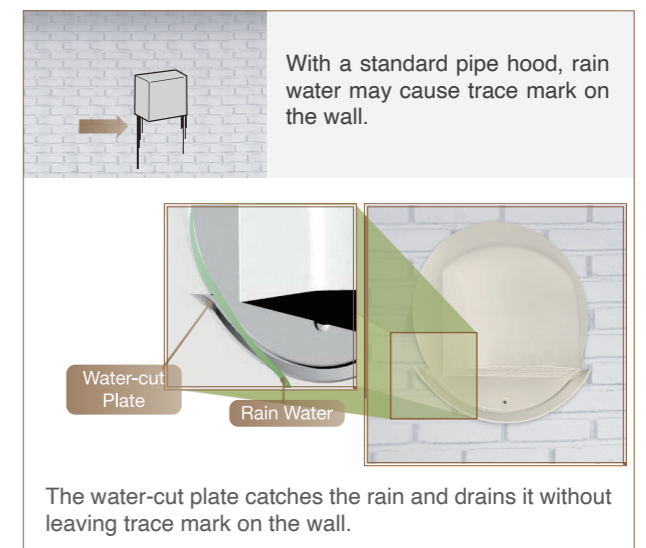

Back Draft Shutter

Shutter Series (For Vertical Shaft) only

Wind from outside may come indoor through the duct when the fan is not operating. The back draft shutter is designed to cover the duct hole to block wind and water.

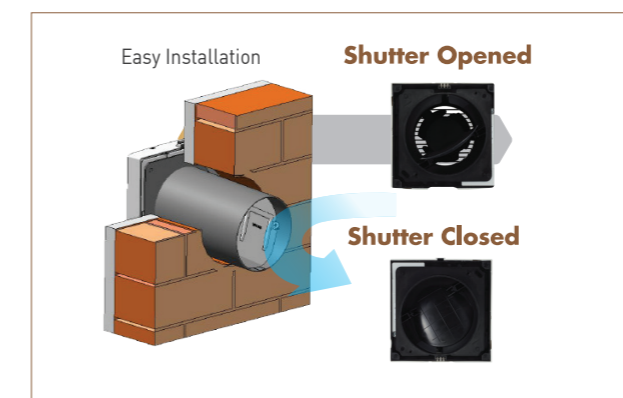

Bathroom Series

Usage: Bathroom Toilet

10EGKB / 15EGKB

Advanced Blade Design

Easy Installation

Pipe Hood Equipped



- Pipe hood series
- Powerful exhaust of excessive moisture and odour
- Prevent rain water trace by water-cut plate at duct ring
- Half pitch condenser motor with thermal cut-off
- Well-lubricated ball bearing for long life operation
- Motor insulation Class E
- IP protection: IPX4 (outside)

Specification

Model	Voltage [V]	Frequency [Hz]	Air Volume [CMH]	Consumption [W]	RPM	Noise [dB(A)]	Weight [kg]	Wall Installation		Ceiling Installation
								Hole Size [mm]	Wall Thickness [mm]	Hole Size [mm]
10EGKB	220	50	76	4.3	2,660	33	1.0	Ø130~140	100~150	Ø130~140
	230	50	77	4.6	2,675	33				
	240	50	77	5.0	2,690	33				
15EGKB	220	50	162	5.7	2,265	36	1.3	Ø175~185	100~150	Ø175~185
	230	50	165	6.1	2,330	37				
	240	50	165	6.5	2,390	37				

Note: RPM data is for reference only, values may vary subject to different conditions

Test Condition

- Air volume, electric characteristic and noise are specified at the static pressure of 0 Pa
- The values of noise level is A weighted average sound pressure level, the mean values are measured by our company, within +3 to -7 dB tolerance
- The values of noise level are measured at 1 m apart from the side of fan body when ducts are connected on outlet side
- The values of air volume are the mid-points of results measured by our company, within ±10% tolerance

Wiring Diagram

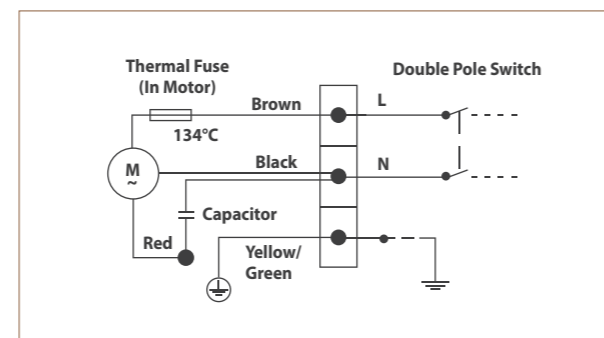

Bathroom Series

Usage: Bathroom Toilet

10EGSB / 15EGSB

Advanced Blade Design

Automatic Shutter

Shutter Equipped



- Shutter series (for vertical shaft)
- Powerful exhaust of excessive moisture and odour
- Half pitch condenser motor with thermal cut-off
- Well-lubricated ball bearing for long life operation
- Motor insulation Class E
- IP protection: IPX4 (outside)

Specification

Model	Voltage [V]	Frequency [Hz]	Air Volume [CMH]	Consumption [W]	RPM	Noise [dB(A)]	Weight [kg]	Wall Installation		Ceiling Installation
								Hole Size [mm]	Duct Space [mm]	Hole Size [mm]
10EGSB	220	50	76	4.3	2,665	35	0.8	Ø120-125	>205	Ø130~140
		60	87	4.7	3,140	37.5				
	230	50	77	4.6	2,670	35				
15EGSB	220	50	155	5.7	2,130	36	1.0	Ø165-170	>240	Ø175~185
		60	180	6.1	2,470	40				
	230	50	160	6.1	2,230	37				
	240	50	165	6.5	2,240	37				

Note: RPM data is for reference only, values may vary subject to different conditions

Test Condition

- Air volume, electric characteristic and noise are specified at the static pressure of 0 Pa
- The values of noise level is A weighted average sound pressure level, the mean values are measured by our company, within +3 to -7 dB tolerance
- The values of noise level are measured at 1 m apart from the side of fan body when ducts are connected on outlet side
- The values of air volume are the mid-points of results measured by our company, within ±10% tolerance

Wiring Diagram

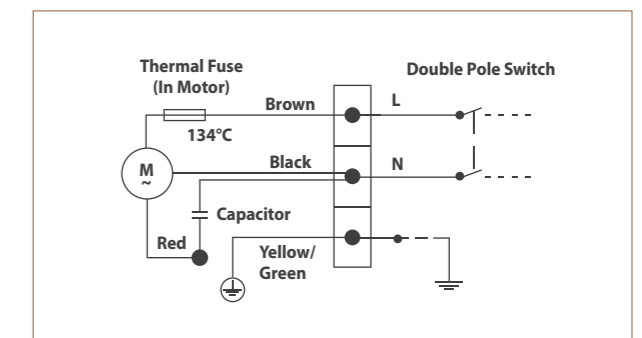

Window Mount Type Ventilation Fan



24-Hour
Ventilation



High Performance



Low-noise



Durable



Scan for more
information



Electric Shutter Series
Able to maintain airtightness



Automatic Shutter Series
Able to maintain airtightness



Cord-operated Shutter Series
Can be easily installed in any glass window



Features of Electric Shutter Series

Rain proof and wind resistible

Hood structure for prevention of rain water ingress

The newly designed shutter can keep out entry of rain water effectively

High static pressure blade can prevent ingress of rain and wind during operation

Bent End Structure of the shutter can block the backflow of outside wind

Easy installation

Mounting Bracket
Unique design of mounting bracket can fix the fan on glass plate with simple process

Packing No Gasket / No Silicon Seal
Attached packing is tightly closed to the glass plate that gets rid of water leakage to indoor

Pervious Setting Method
Both gasket & silicon seal are not required for 15WHCT/20WHCT

e.g. 15WHCT
Orifice is not necessary to detach for installation. Simply fix the fan on glass plate by screws at front.

High adaptability

New mounting design allows the fan to be fixed on glass plate of thickness from 3mm up to 25mm with ease

Double glass
Often called insulated glass that consists of two panes of glass set apart to allow airspace in. This airspace acts as a buffer which obstructs the transfer of heat from one side of the glass to the other.

Applicable Glass Thickness 3mm-25mm

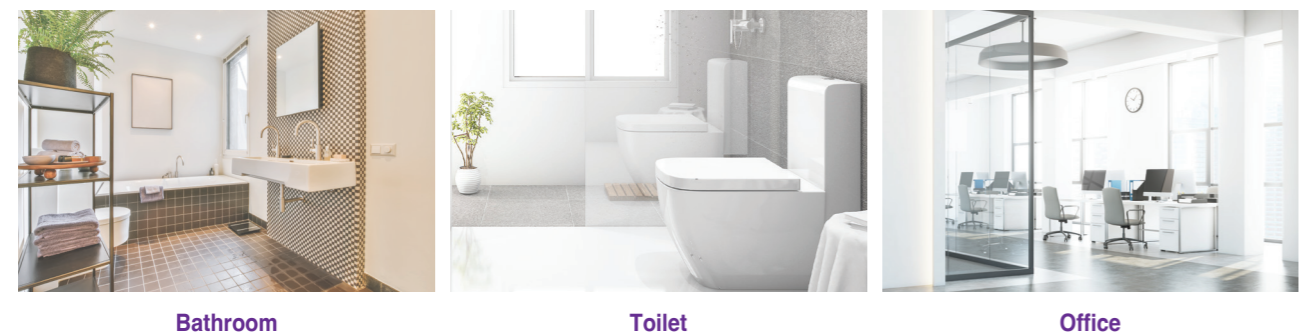

Bathroom

Toilet

Office

Electric Shutter Series

Usage: Bathroom Toilet Office / Retail Store

15WHCT / 20WHCT

- Louver for Protection
- Rain proof and wind resistible
- Prevent Rain and Wind

Dimension
Unit : mm

Model	A	B	C	C'	D
15WHCT	224	182	117	111	72
20WHCT	288	243	120	117	74

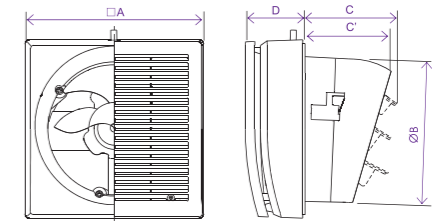

- Electrically operated shutter
- Advanced design hood structure to prevent rain and wind
- Suitable for window glass with thickness from 3mm to 25mm
- Simple and easy installation, no need of any silicon seal or gasket
- Motor insulation Class E
- IP protection: IPX4 (outside)

Specification

Model	Voltage [V]	Frequency [Hz]	Air Volume		Consumption [W]	Noise [dB(A)]	Weight [kg]	Installation Space [mm]
			[CMH]	[CFM]				
15WHCT	220	50	230	135	13	43	1.4	Ø186 - Ø188
		60	230	135	13	44		
		230	50	230	135	14		
20WHCT	220	50	445	262	20	42	2.6	Ø247 - Ø250
		60	480	283	22	45		
		230	50	445	262	21		
		240	50	445	262	22	42	

- Note:
- The value of power consumption, air volume and noise are specified at the static pressure of 0 Pa.
 - The value of air volume is the mean value which is measured by our company.
 - The value of noise level is measured at 1m apart from the left, the right and the front of product, then get the average of three values.
 - The value of noise level is A weight average sound pressure level, the mean value is measured by our company.

Installation Example

Model No.	A	B	C
15WHCT	186-188mm	390mm Min	100mm Min
20WHCT	247-250mm	450mm Min	100mm Min

Wiring Diagram

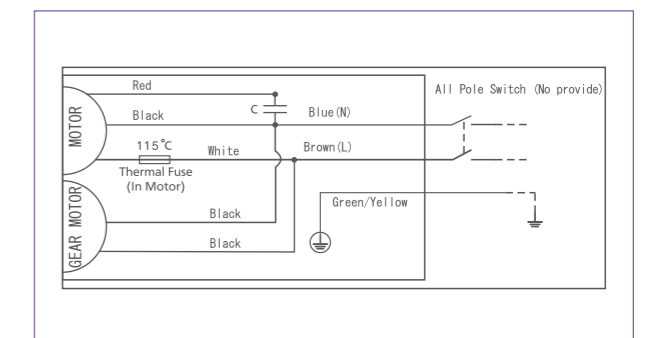

Features of Automatic Shutter Series

Auto Shutter

The backdraft shutters will be opened by air pressure during operation and closed automatically for air-tightness when the fan is switched off.

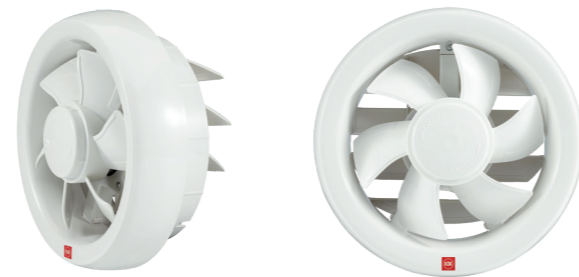

Advanced Blade Design

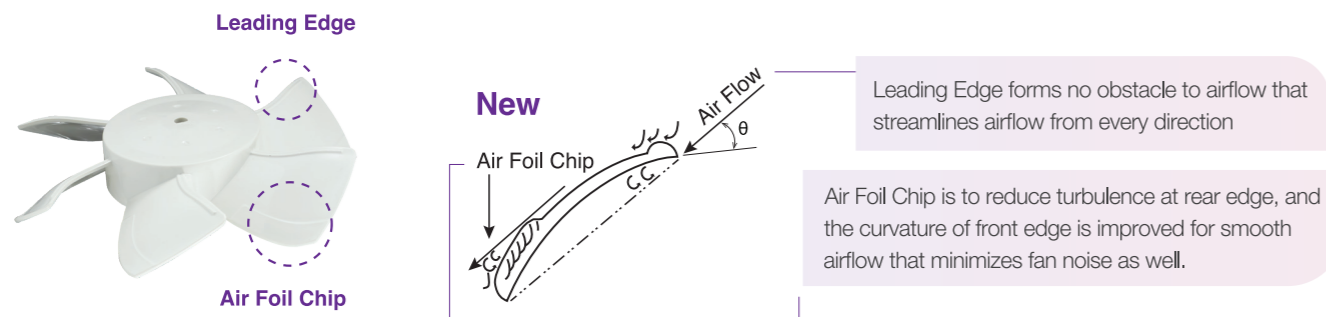

Half pitch condenser motor with well-lubricated ball bearing

- Low power consumption (50% down VS previous model)
- Low noise level (6% down VS previous model)
- Long life up to 40,000 hours (1.5 time VS previous model)
- Comply with IPX4 (outside)

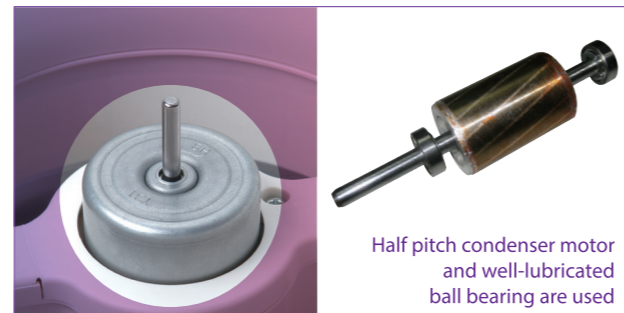

Easy Maintenance

The blade can be detached by simply loosening the spinner, that facilitates the periodical maintenance.

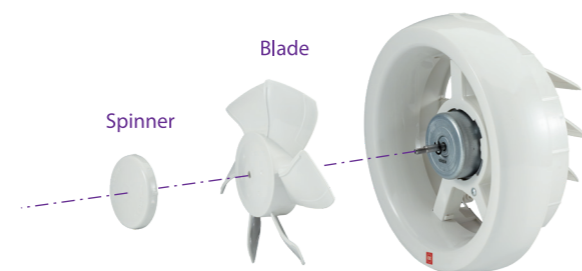

Bathroom



Toilet



Office

Automatic Shutter Series

Usage: Bathroom Toilet Office / Retail Store

15WAA / 15WAAMN
20WAA / 20WAAMN

Automatic Shutter

Advanced Blade Design

Easy Maintenance

Dimension

Unit : mm

Model	A	B	C	D	E	F	G	H(MAX)
15WAA	150	212	100	47	53	38	175	(30)
20WAA	206	290	122	76	46	59	237	(36)

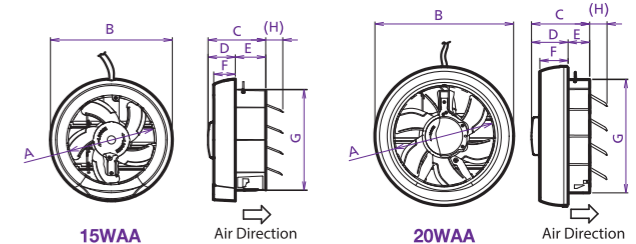

- Automatic shutter
- Half pitch condenser motor with thermal cut-off
- Well-lubricated ball bearing for long life operation
- Propeller fan incorporated with advanced blade design
- Removable blade for easy maintenance
- Motor insulation Class E
- IP protection: IPX4 (outside)

Specification

Model	Voltage [V]	Frequency [Hz]	Air Volume		Consumption [W]	Noise [dB(A)]	Weight [kg]	Installation Space [mm]
			[CMH]	[CFM]				
15WAA	220	50	210	124	14	43	0.9	Ø186 - Ø188
		60	222	131	18	44		
15WAA / 15WAAMN	230	50	222	131	15	44	1.4	Ø247 - Ø250
	240	50	228	134	16	44		
20WAA	220	50	380	224	15	42	1.4	Ø247 - Ø250
		60	380	224	17	42		
20WAA / 20WAAMN	230	50	390	230	16	43	1.4	Ø247 - Ø250
	240	50	401	237	17.5	43		

Note:

- 1.The value of power consumption, air volume and noise are specified at the static pressure of 0 Pa.
- 2.The value of air volume is the mean value which is measured by our company.
- 3.The value of noise level is measured at 1m apart from the left, the right and the front of product, then get the average of three values.
- 4.The value of noise level is A weight average sound pressure level, the mean value is measured by our company.

Installation Example

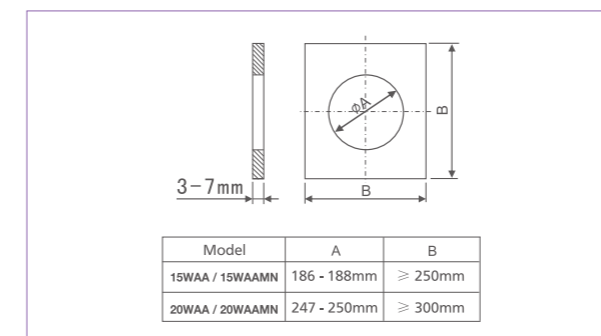

Wiring Diagram

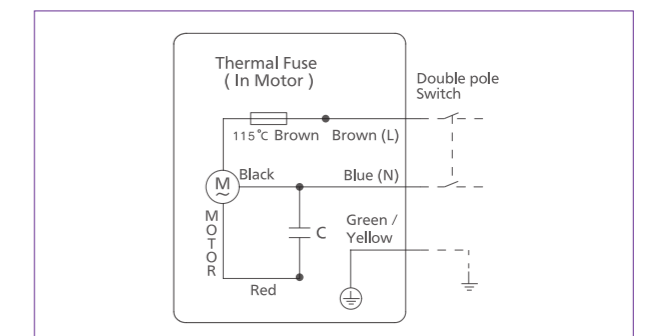

Features of Cord-Operated Shutter Series

Strengthened Shutter Structure



Advanced Blade Design

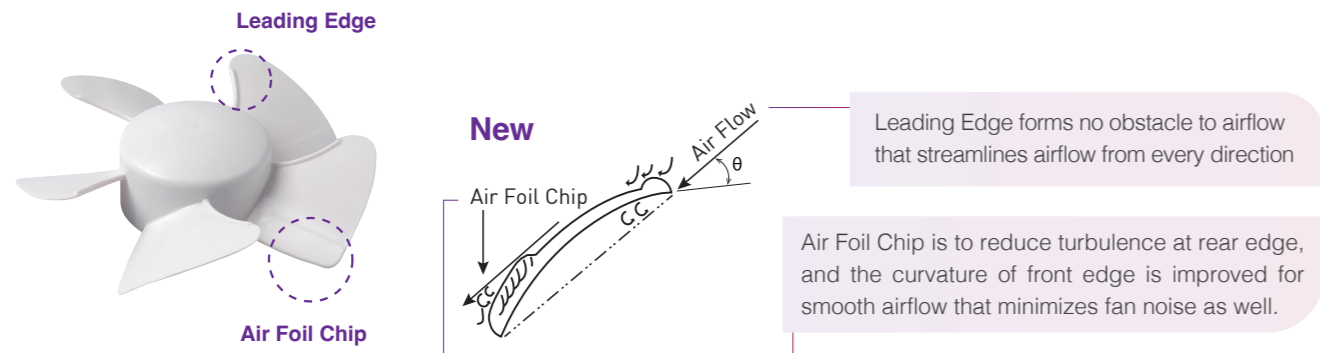

Easy Maintenance

The blade can be detached by simply loosening the spinner, that facilitates the periodical maintenance.

Half pitch condenser motor with well-lubricated ball bearing

- Low power consumption (50% down VS previous model)
- Low noise level (6% down VS previous model)
- Long life up to 40,000 hours (1.5 time VS previous model)
- Comply with IPX4 (outside)

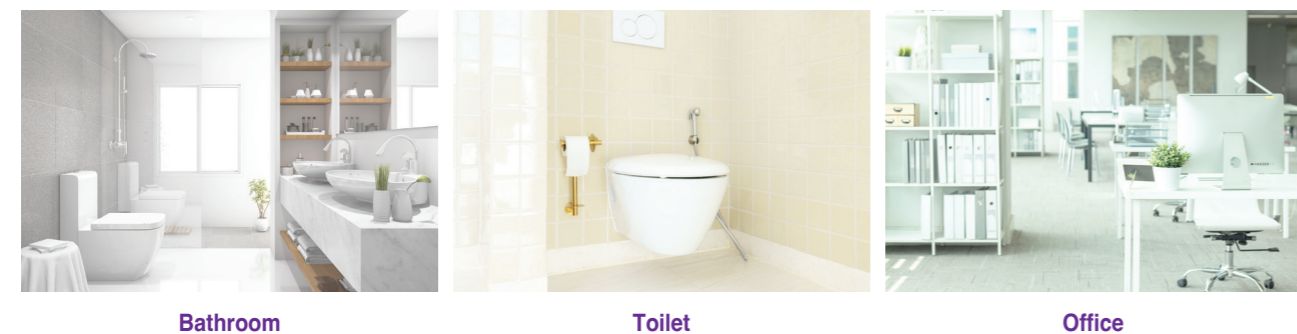

Cord-Operated Shutter Series

Usage: Bathroom Toilet Office / Retail Store

15WUD / 15WUDMN
20WUD / 20WUDMN

- Cord-operated Shutter
- Advanced Blade Design
- Metallic Shutter Axis

Dimension
Unit : mm

Model	A	B	C	D	E	F	G	H
15WUD	150	210	97	43	54	37	177	149
20WUD	200	271	98	36	62	36	237	201

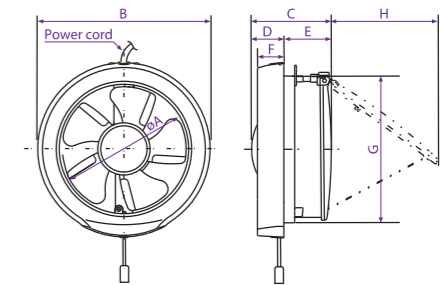

- Half pitch condenser motor with thermal cut-off
- Well-lubricated ball bearing for long life operation
- Propeller fan incorporated with advanced blade design
- Shutter operated by pull cord
- Metallic shutter axis
- Motor insulation Class E
- IP protection: IPX4 (outside)

Specification

Model	Voltage [V]	Frequency [Hz]	Air Volume		Consumption [W]	Noise [dB(A)]	Weight [kg]	Installation Space [mm]
			[CMH]	[CFM]				
15WUD	220	50	210	124	8.1	35	0.9	Ø186 - Ø188
		60	200	118	8.9	34		
15WUD / 15WUDMN	230	50	220	129	8.8	35		
20WUD	240	50	230	135	9.5	36		
20WUD	220	50	360	212	16.4	32	1.1	Ø247 - Ø250
		60	360	212	19	31		
20WUD / 20WUDMN	230	50	380	224	17.9	34		
20WUD / 20WUDMN	240	50	400	235	19.5	36		

- Note:
- 1.The value of power consumption, air volume and noise are specified at the static pressure of 0 Pa.
 - 2.The value of air volume is the mean value which is measured by our company.
 - 3.The value of noise level is measured at 1m apart from the left, the right and the front of product, then get the average of three values.
 - 4.The value of noise level is A weight average sound pressure level, the mean value is measured by our company.

How to Turn On

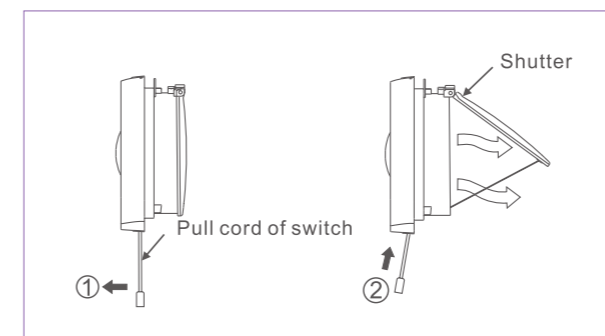

How to Turn Off

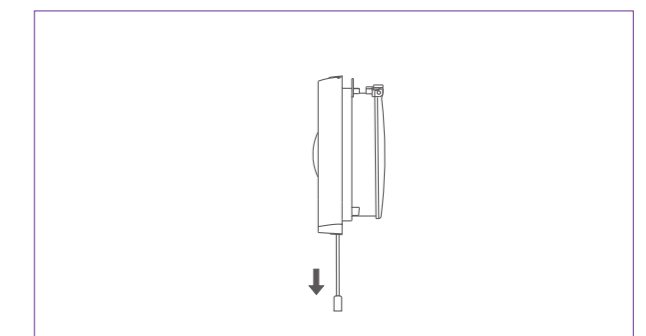

Industrial Type Ventilation Fan



High Performance



Low-noise



Durable

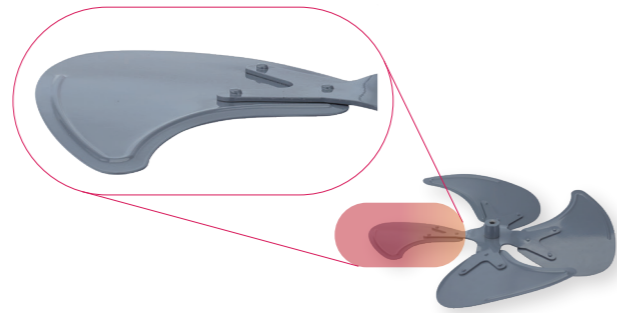

Fans with 3D Wave-shaped Cross Section Blade*

*The 3D wave-shaped blade only applicable to some of the models

Shutter Series

Usage: Factory Warehouse Retail Store Commercial Kitchen

40KAQA

High Pressure

Rust Resistant

Shutter

Dimension

Unit : mm

Model	A	B	C	D	E	F	G	H	I
40KAQA	510	480	215	40	55	434	10	126	130

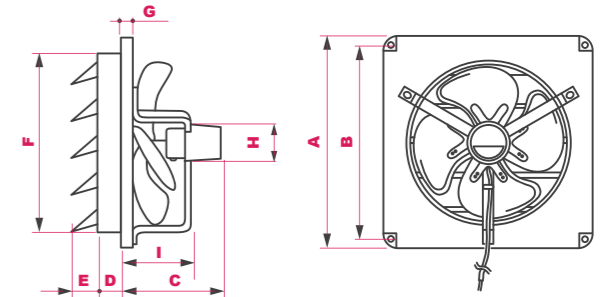

- With shutter
- Durable powder coating for rust resistance
- High performance condenser motor with thermal cut-off
- Operable at an ambient temperature range from -10°C to +50°C
- Motor insulation Class E
- IP protection: IPX4 (outside)

Specification

Model	Voltage [V]	Frequency [Hz]	Air Volume		Current [A]	Input [W]	Noise [dB(A)]	RPM	Weight [kg]	Installation Space W x L [mm]
			[CMH]	[CFM]						
40KAQA	220	50	1,880	1,105	0.260	47.0	51.0	1,230 ~ 1,370	6.4	444 x 444
	230		1,920	1,130	0.270	52.0	51.0	1,250 ~ 1,390		
	240		1,960	1,155	0.290	59.0	51.0	1,270 ~ 1,410		
	230	60	2,130	1,254	0.310	67.0	52.5	1,400 ~ 1,540		

Note: RPM data is for reference only. Values may vary depending on different conditions.

1. The value of power consumption, air volume and noise are specified at the static pressure of 0 Pa.

2. The value of air volume is the mean value which is measured by our company.

3. The value of noise level is measured at 1m apart from the left, the right and the front of product, then get the average of three values.

4. The value of noise level is A weight average sound pressure level, the mean value is measured by our company.

Installation

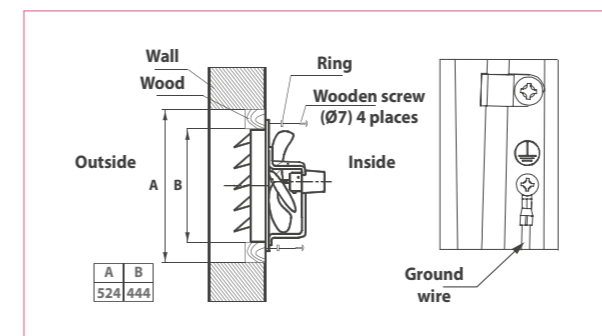

Wiring Diagram

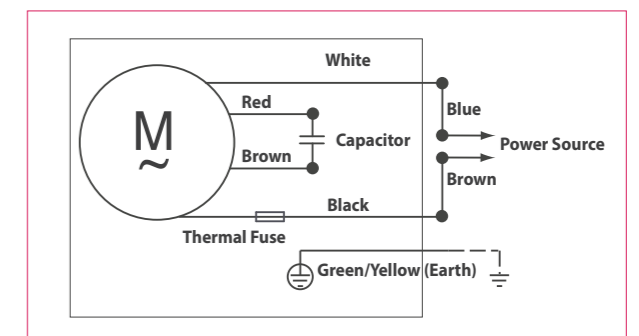

Scan for more information



High Pressure Series

Usage: Factory Warehouse Retail Store Commercial Kitchen

25GSE / 30GSE / 35GSE

Dimension
Unit : mm

Single Phase

Reversible

Optional Shutter

Model	A	B	C	D	E	F	G	H
25GSE	327	298	165	-	171	10	-	250
30GSE	378	349	210	-	200	10	-	300
35GSE	467	434	250	-	235	12	-	350

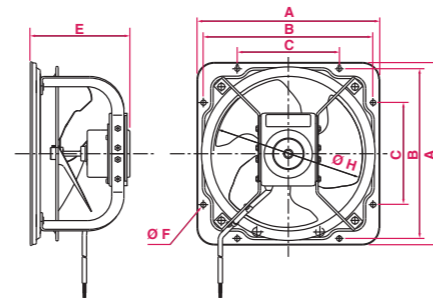

- Bell mouth construction with distinctive wave-shaped blade
- Durable powder coating
- Operable at an ambient temperature range from -10°C to +50°C
- Possible to install horizontally or vertically
- Motor insulation Class E
- IP protection: IPX4 (outside)

Specification

Model	Voltage [V]	Frequency [Hz]	Air Volume		Consumption [W]	Noise [dB(A)]	Weight [kg]
			[CMH]	[CFM]			
25GSE	220	50	1,280	753	41	44	2.0
		60	1,440	848	57	46	
	230	50	1,280	753	43	44	
30GSE	220	50	2,150	1,265	87	49	2.5
		60	2,390	1,407	119	51	
	230	50	2,150	1,265	92	49	
35GSE	220	50	2,950	1,736	113	51	2.9
		60	3,380	1,989	161	54	
	230	50	2,950	1,736	118	51	
	240	50	2,950	1,736	122	51	

Test Condition

- Air volume, electric characteristic and noise are specified at the static pressure of 0 Pa
- The values of noise level is A weighted average sound pressure level, the mean values are measured by our company, within +3 to -7 dB tolerance
- The values of noise level are measured at 1 m apart from the side of fan body
- The values of air volume are the mid-points of results measured by our company, within ±10% tolerance

Wiring Diagram

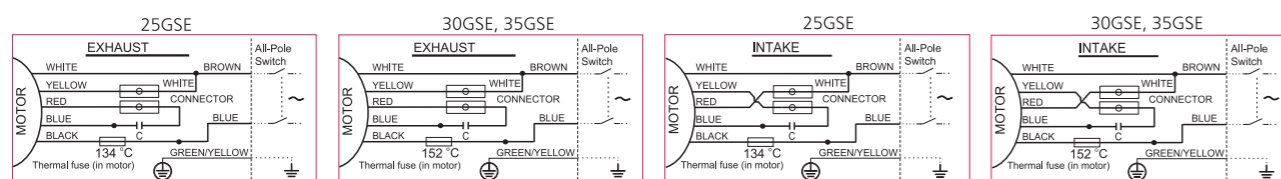

High Pressure Series

Usage: Factory Warehouse Retail Store Commercial Kitchen

40GSE

Dimension
Unit : mm

Single Phase

Reversible

Optional Shutter

Model	A	B	C	D	E	F	G	H
40GSE	518	485	280	460	274	12	12	400

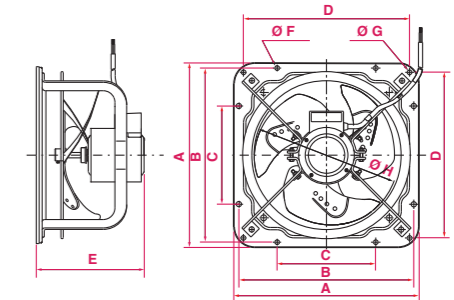

- Bell mouth construction with distinctive wave-shaped blade
- Durable powder coating
- Operable at an ambient temperature range from -10°C to +50°C
- Possible to install horizontally or vertically
- Motor insulation Class B
- IP protection: IPX4 (outside)

Specification

Model	Voltage [V]	Frequency [Hz]	Air Volume		Consumption [W]	Noise [dB(A)]	Weight [kg]
			[CMH]	[CFM]			
40GSE	220	50	3,900	2,295	141	54	19.0
		60	4,890	2,878	270	58	
	230	50	3,900	2,295	146	54	
	240	50	3,900	2,295	151	54	

Test Condition

- Air volume, electric characteristic and noise are specified at the static pressure of 0 Pa
- The values of noise level is A weighted average sound pressure level, the mean values are measured by our company, within +3 to -7 dB tolerance
- The values of noise level are measured at 1 m apart from the side of fan body
- The values of air volume are the mid-points of results measured by our company, within ±10% tolerance

Wiring Diagram

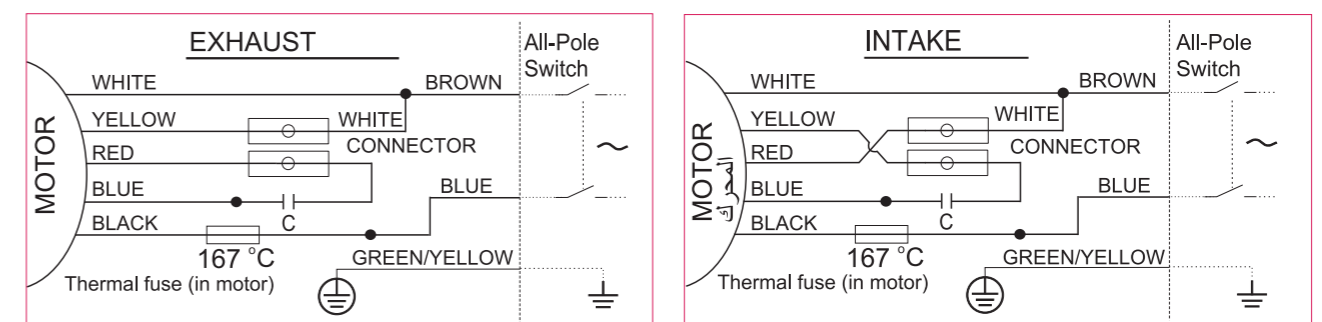

High Pressure Series

Usage: Factory Warehouse Retail Store Commercial Kitchen

45GSC / 50GSC / 60GSC

Dimension
Unit : mm

Single Phase

Reversible

Optional Shutter

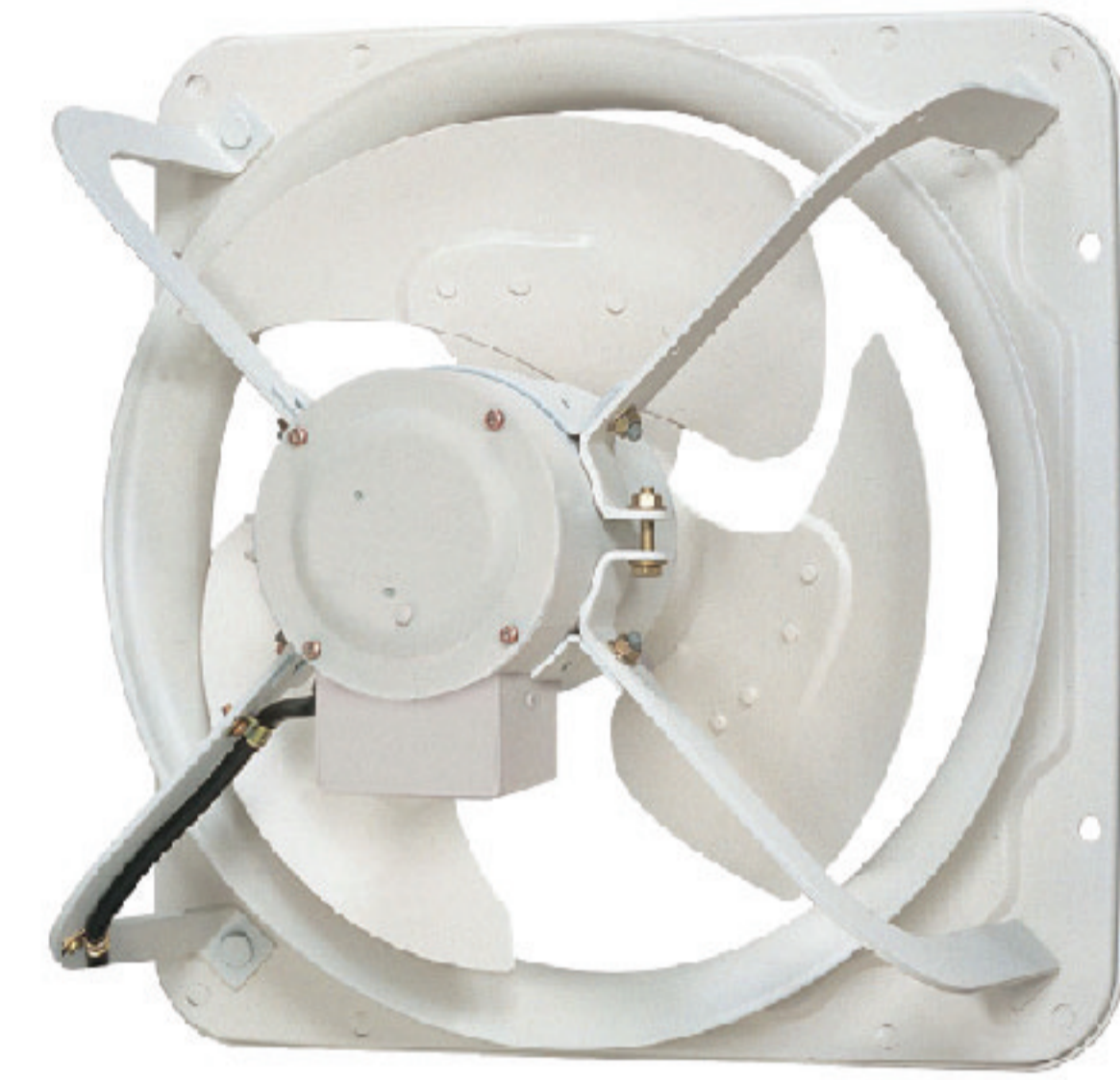

Model	A	B	C	D	E	F	G
45GSC	450	570	540	-	320	297	12
50GSC	500	659	620	560	355	315	15
60GSC	620	760	720	650	400	320	15

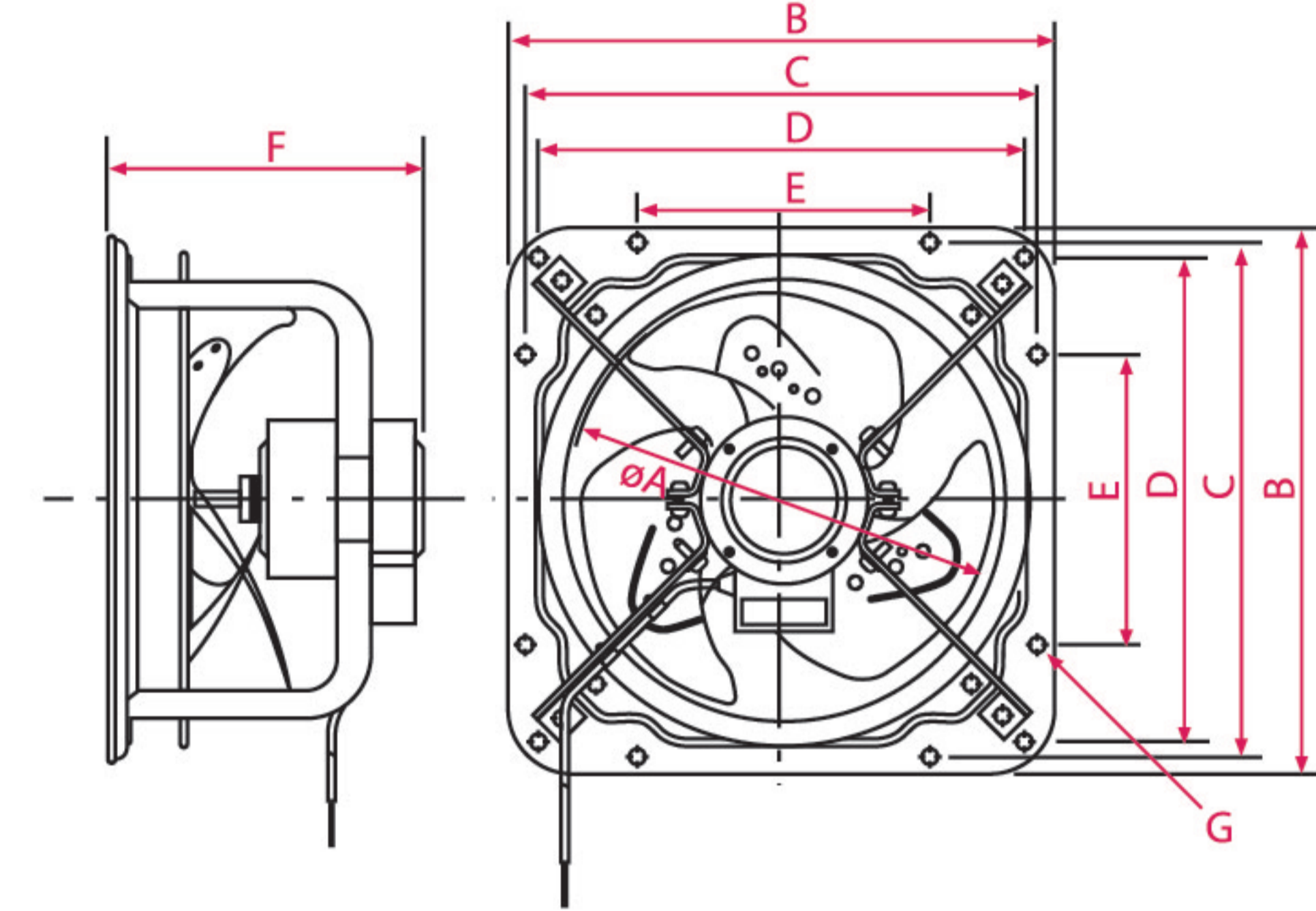

- Bell mouth construction with distinctive wave-shaped blade
- Durable powder coating
- Operable at an ambient temperature range from -10°C to +50°C
- Possible to install horizontally or vertically
- Motor insulation Class E

Specification

Model	Voltage [V]	Frequency [Hz]	Air Volume		Consumption [W]	Noise [dB(A)]	Weight [kg]
			[CMH]	[CFM]			
45GSC	220	50	5,200	3,061	227	51	19.0
		60	5,970	3,514	325	54	
	230	50	5,430	3,196	235	51	
		240	50	5,460	3,214	241	
50GSC	220	50	6,130	3,608	249	47	22.5
		60	7,100	4,179	326	51	
	230	50	6,420	3,779	258	47	
		240	50	6,480	3,814	271	
60GSC	220	50	8,040	4,732	245	50	34.0
		60	9,410	5,539	361	54	
	230	50	8,460	4,979	258	50	
		240	50	8,490	4,997	263	

Test Condition

- Air volume, electric characteristic and noise are specified at the static pressure of 0 Pa
- The values of noise level is A weighted average sound pressure level, the mean values are measured by our company, within +3 to -7 dB tolerance
- The values of noise level are measured at 1 m apart from the side of fan body
- The values of air volume are the mid-points of results measured by our company, within ±10% tolerance

Wiring Diagram

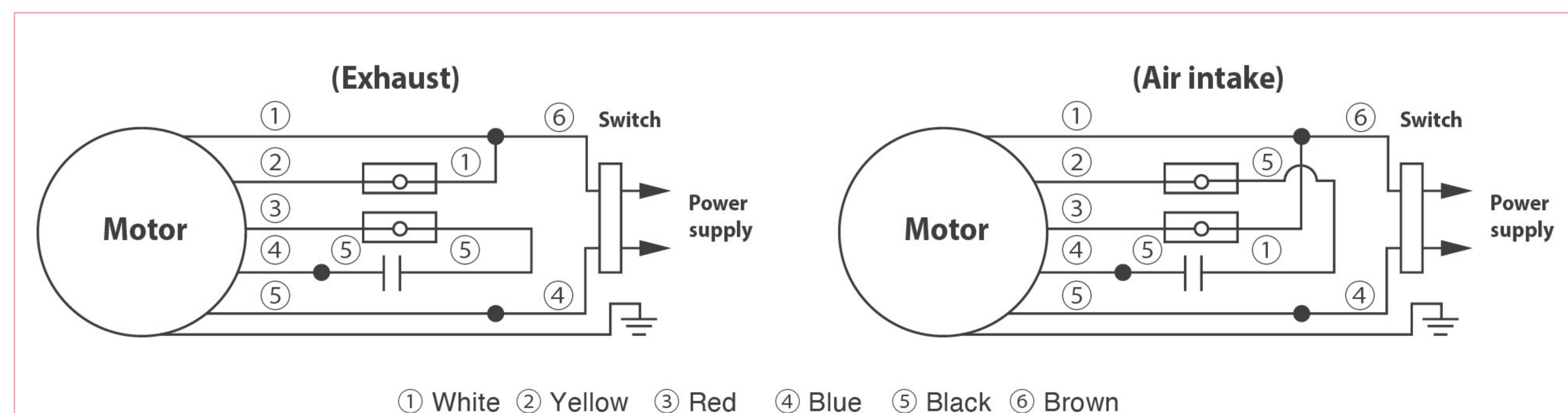

High Pressure Series

Usage: Factory Warehouse Retail Store Commercial Kitchen

45GTC / 50GTC / 60GTC

Dimension
Unit : mm

Three Phase

Reversible

Optional Shutter

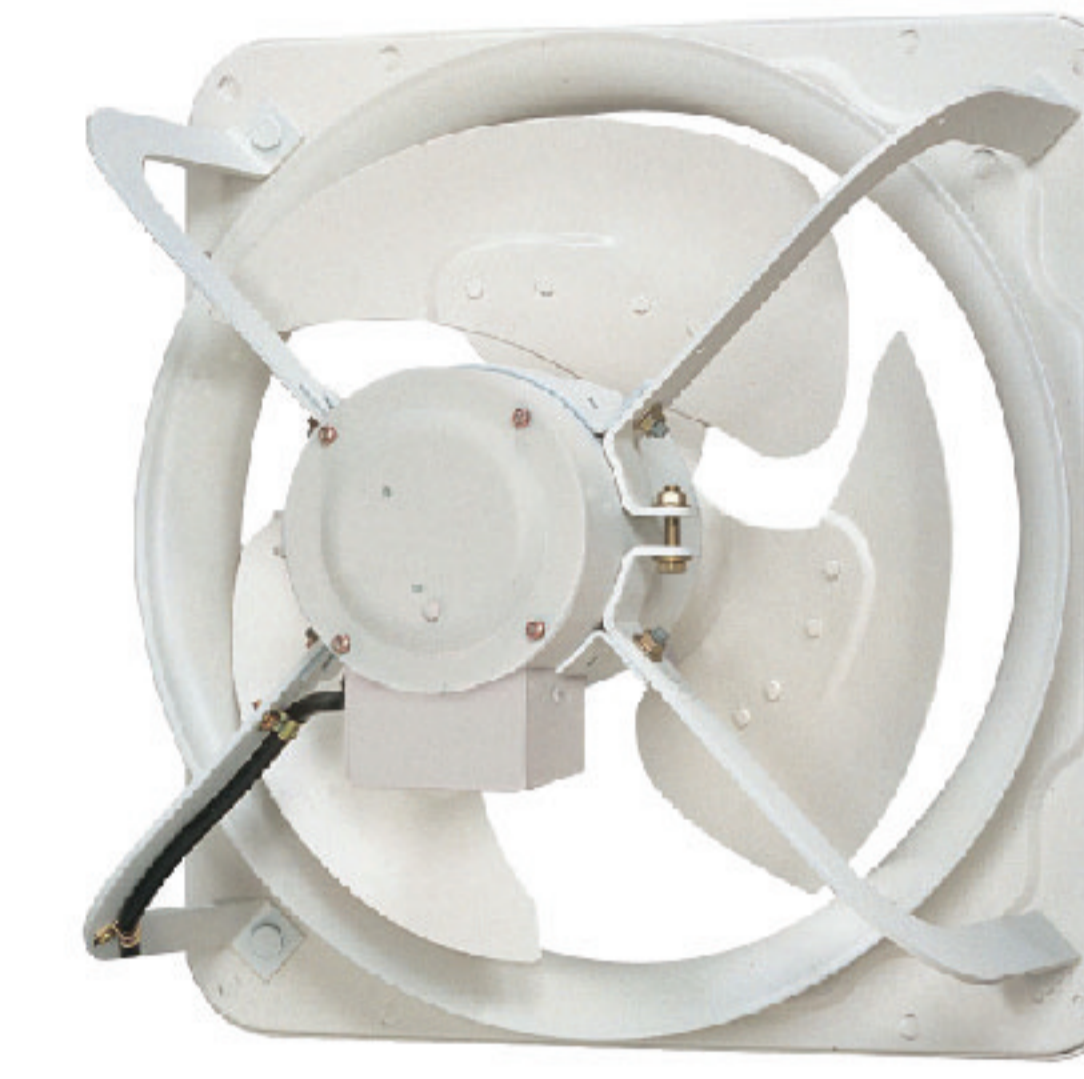

Model	A	B	C	D	E	F	G
45GTC	450	570	540	-	320	297	12
50GTC	500	659	620	560	355	304	15
60GTC	620	760	720	650	400	320	15

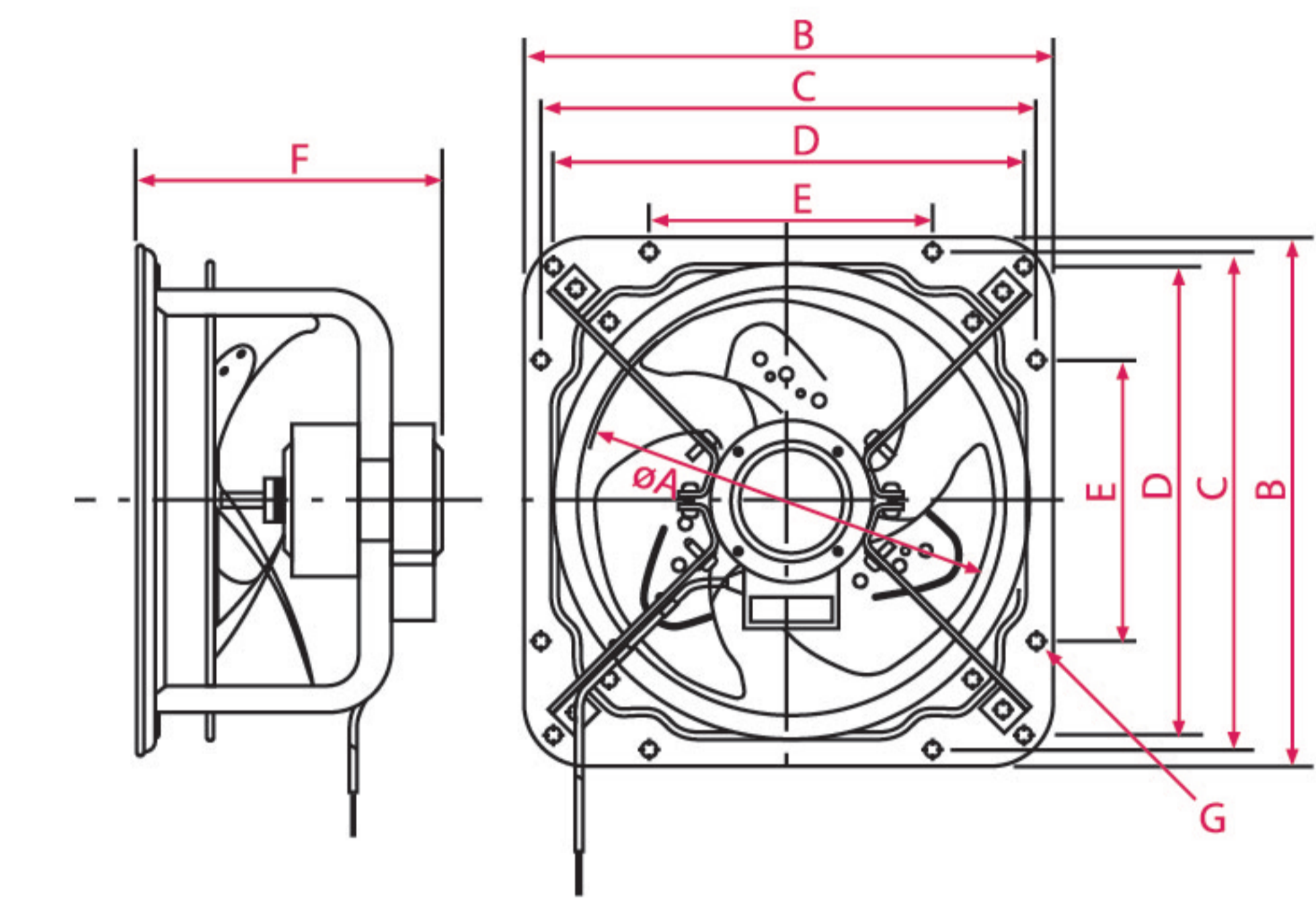

- Bell mouth construction with distinctive wave-shaped blade
- Durable powder coating
- Operable at an ambient temperature range from -10°C to +50°C
- Possible to install horizontally or vertically
- Motor insulation Class E

Specification

Model	Voltage [V]	Frequency [Hz]	Air Volume		Consumption [W]	RPM	Noise [dB(A)]	Weight [kg]
			[CMH]	[CFM]				
45GTC	380	50	5,520	3,249	220	1,450	52	18.5
		60	6,420	3,779	330	1,690	56	
50GTC	380	50	6,960	4,097	320	1,400	54	28.5
		60	8,010	4,715	475	1,590	58	
60GTC	380	50	9,420	5,544	310	940	49	34
		60	10,920	6,427	450	1,070	53	

- Performance certified is for installation type A: Free inlet, Free outlet with partition. Performance ratings include the effects of an inlet grill and backdraft damper. The speed (RPM) and Watts rating shown are at the static pressure of 0 inch of H₂O. The sound ratings shown are loudness values in fan sones at 5 ft. (1.5m) in a hemispherical free field calculated per AMCA International Standard 301. Values shown are for installation type A: Free inlet hemispherical sone levels.
- *the Watts rating is only for AMCA test method and it is at the static pressure of 0 inch of H₂O.
- **the Watts rating is only for IEC test method and the AMCA Certified Ratings Seal does not apply to IEC test method watts.

Wiring Diagram

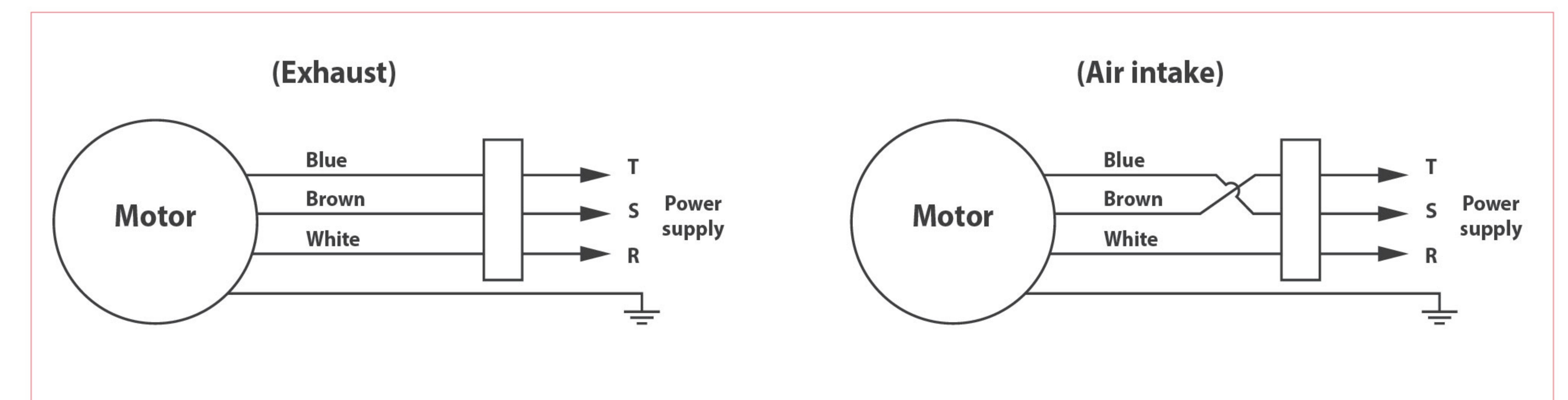

Optional Accessories

25GASC / 30GASC / 35GASC
40GASC / 45GASC / 50GASC / 55GASC

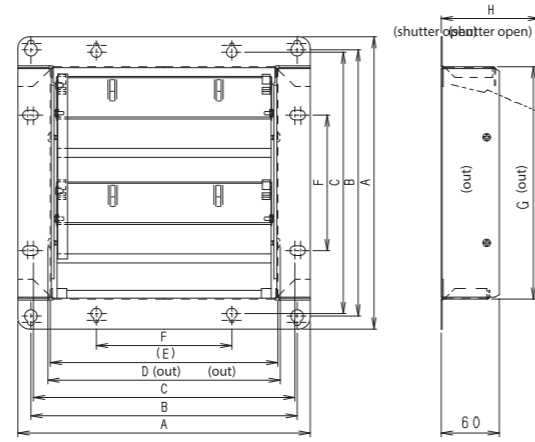

- Auto shutter for High Pressure Series
- Steel material
- Durable powder coating
- Available for wall mounting

Dimension Unit : mm

Model	Size	A	B	C	D	E	F	G	H	No. of Shutter	Applicable for
25GASC	25cm/10"	330	303	298	268	263	165	268	137	2	25GSE
30GASC	30cm/12"	381	354	349	319	314	210	319	122	3	30GSE
35GASC	35cm/14"	468	433	434	389	384	250	389	137	3	35GSE
40GASC	40cm/16"	519	484	485	440	435	280	440	122	4	40GSE
45GASC	45cm/18"	574	539	540	492	487	320	492	137	5	45GSC,45GTC
50GASC	50cm/20"	660	625	620	545	540	355	545	122	5	50GSC,50GTC
55GASC	60cm/24"	760	725	720	662	657	440	662	122	6	60GSC,60GTC

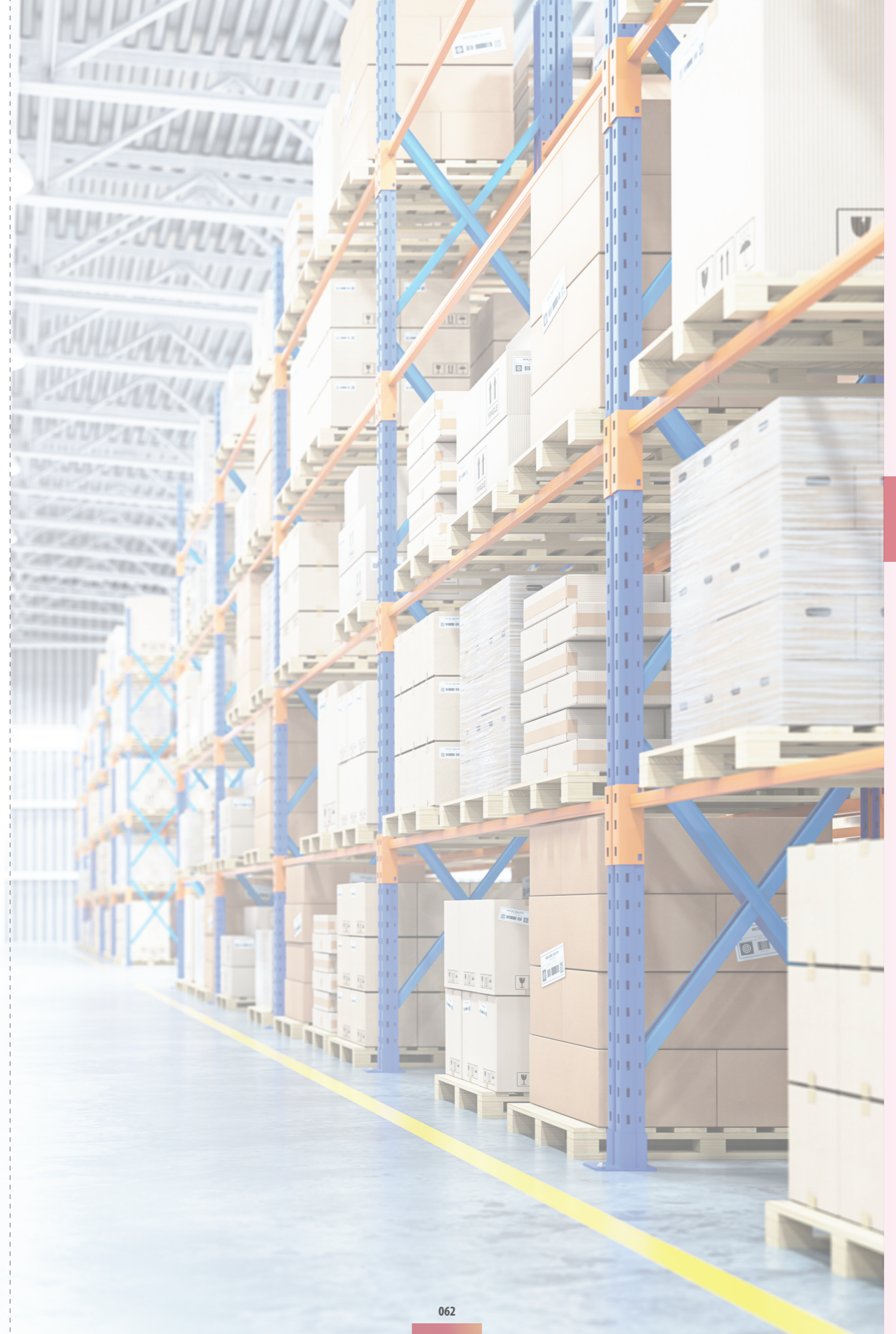

Cabinet Fan (In-line Fan)

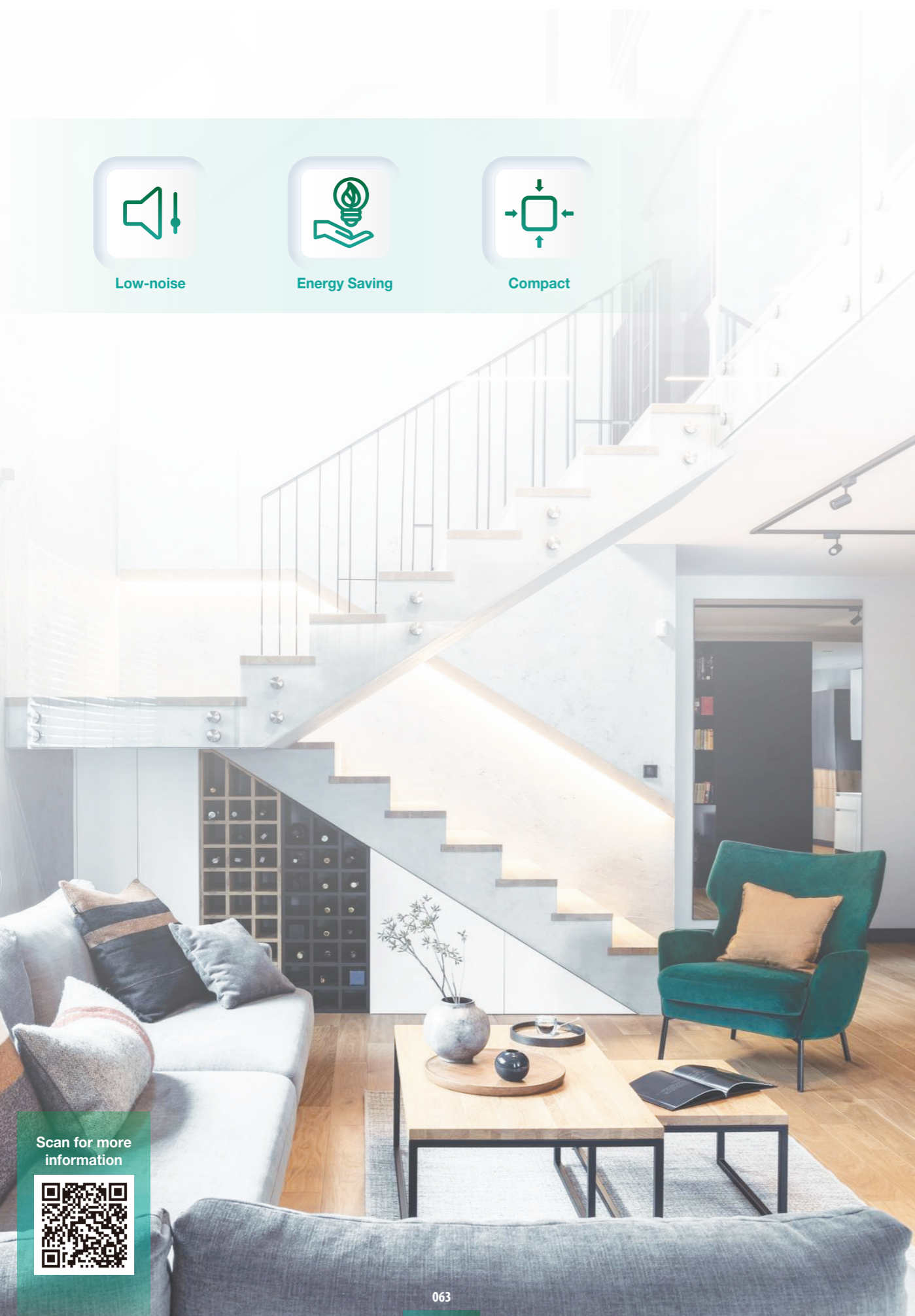

Low-noise



Energy Saving



Compact

Scan for more information



Low-noise Design

The newly developed twin flow fan achieves a better airflow inside the fan casing. It is divided into two portions which can generate large air volume and high static pressure respectively.

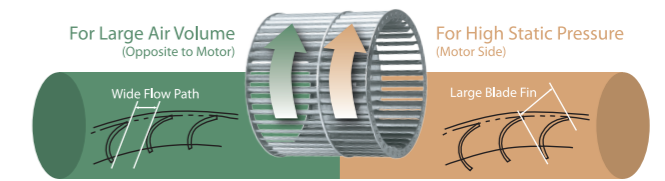

Tapered Scroll

Wind velocity varies according to the shape of the casing. The tapered scroll at the casing minimizes turbulence induced by uneven wind velocity inside the casing.

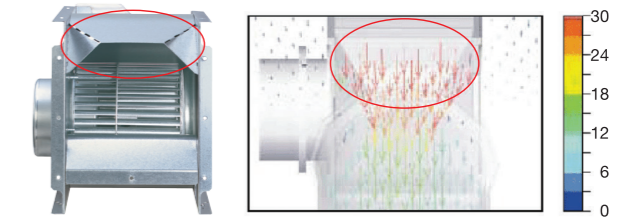

Internal Wind Velocity Distribution - Airflow Analysis

Embedded Terminal Box

Terminal box is embedded into the product frame. The wiring to power supply is covered with metal enclosure that enhances the durability and safety level.

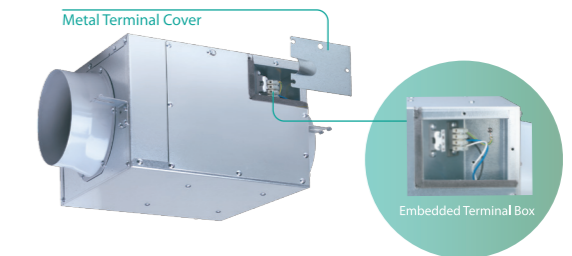

High Static Pressure

The distinctive design of twin flow fan and fan casing enable operation with high static pressure, which is approximate 10% average increased when compared with previous models. This increases the flexibility in your planning of ventilating system.

Energy Saving

The new structure design improves fan performance by increasing energy efficiency by 3%. In addition, energy saving is assured by reducing motor power consumption significantly.

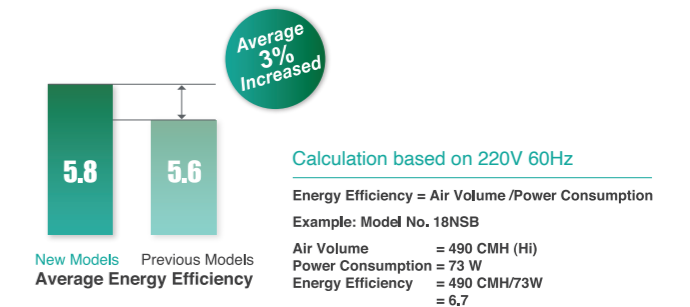

Noise Reduction

With the twin flow fan and fan casing structure, the new models minimize the transmission of noise and reduce it by 6% while maintaining air volume. This technology creates a more tranquil and pleasant environment.

Easy Installation

A slim, compact and light body allows easy installation in narrow ceiling space, when compared with previous models.

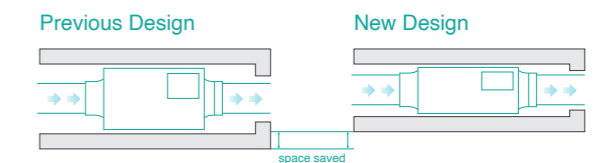

Compact Size

With the newly designed structure, the product size is reduced by 9%, which increases the flexibility in installation.

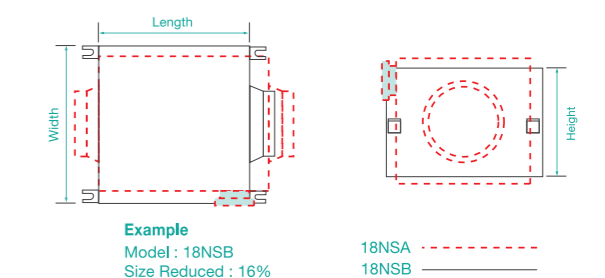

Standard Series

Usage: Living Room Shopping Mall Restaurant

12NSB / 15NSB

Dimension
Unit : mm

- Sirocco Fan
- Low Noise Design
- Compact Size

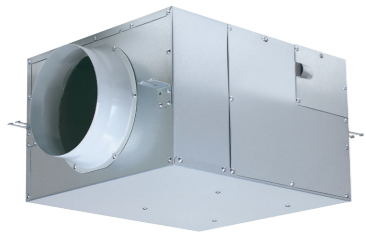

Model	A	B	C	D	E	F	G	H	I
12NSB	290	250	291	335	184	92	97	112	51
15NSB	290	250	302	346	206	103	145	163	60

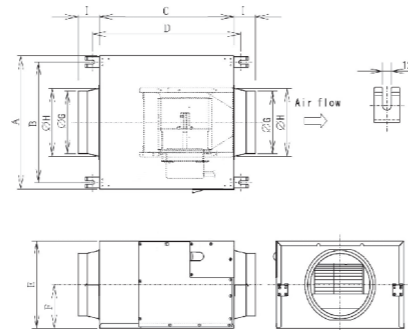

- Long life condenser motor with thermal cut-off
- Twin flow fan (sirocco fan)
- Fan casing with tapered scroll
- Embedded terminal box
- Noise absorption material adopted
- Motor insulation Class E
- IP protection: IPX2

Specification

Model	Voltage [V]	Frequency [Hz]	Air Volume		Consumption [W]	Noise [dB(A)]	Weight [kg]	Duct Size [mm]	Impeller Diameter [mm]	
			[CMH]	[CFM]						
12NSB	220	50	Hi	180	106	18	21	5.5	Ø100	128
			Lo	145	85	17	17			
		60	Hi	190	112	23	22			
	Lo	145	85	19	18					
	230	50	Hi	180	106	20	21			
		50	Lo	150	88	18	18			
Hi			185	109	22	22				
15NSB	220	50	Lo	155	91	19	20	6.5	Ø150	128
			Hi	340	200	33	25			
		60	Lo	275	162	29.5	22			
	Hi	370	218	42	27					
	230	50	Lo	260	153	33	22			
			Hi	340	200	35	25			
50		Lo	280	165	31	22				
240	50	Hi	350	206	37	26				
		Lo	290	171	33	24				

Test Condition

- Air volume, electric characteristic and noise are specified at the static pressure of 0 Pa
- The values of noise level is A weighted average sound pressure level, the mean values are measured by our company, within +3 to -7 dB tolerance
- The values of noise level are measured at 1.5 m apart from the side of fan body when ducts are connected on outlet side
- The values of air volume are the mid-points of results measured by our company, within ±10% tolerance

Wiring Diagram

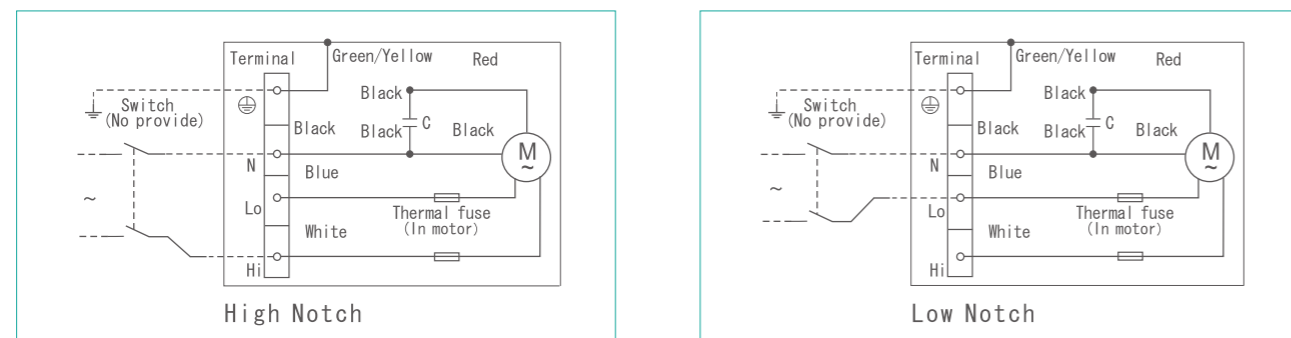

Standard Series

Usage: Living Room Shopping Mall Restaurant

18NSB / 18NFB

Dimension
Unit : mm

- Sirocco Fan
- Low Noise Design
- Compact Size

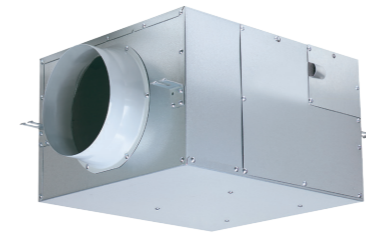

Model	A	B	C	D	E	F	G	H	I
18NSB	316	276	338	382	232	116	145	163	60
18NFB	376	336	397	441	254	127	195	211	70

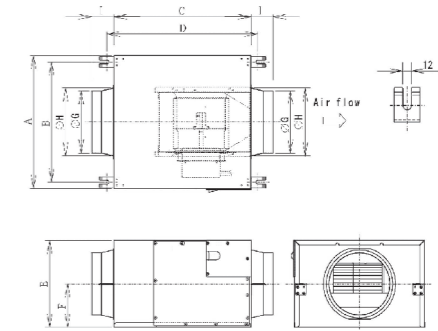

- Long life condenser motor with thermal cut-off
- Twin flow fan (sirocco fan)
- Fan casing with tapered scroll
- Embedded terminal box
- Noise absorption material adopted
- Motor insulation Class E
- IP protection: IPX2

Specification

Model	Voltage [V]	Frequency [Hz]	Air Volume		Consumption [W]	Noise [dB(A)]	Weight [kg]	Duct Size [mm]	Impeller Diameter [mm]	
			[CMH]	[CFM]						
18NSB	220	50	Hi	500	294	60	29	8.5	Ø150	158
			Lo	405	238	55	27			
		60	Hi	490	288	73	30			
	Lo	385	277	62.5	26					
	230	50	Hi	500	294	65	30			
			Lo	420	247	58.5	28			
50		Hi	510	300	68	31				
18NFB	220	50	Lo	430	253	63.5	28	10.0	Ø200	158
			Hi	770	453	91	31			
		60	Lo	620	365	80	29			
	Hi	760	447	119	32					
	230	50	Lo	580	341	87	28			
			Hi	770	453	96	32			
50		Lo	620	365	82	29				
240	50	Hi	780	459	104	33				
		Lo	640	377	86	29				

Test Condition

- Air volume, electric characteristic and noise are specified at the static pressure of 0 Pa
- The values of noise level is A weighted average sound pressure level, the mean values are measured by our company, within +3 to -7 dB tolerance
- The values of noise level are measured at 1.5 m apart from the side of fan body when ducts are connected on outlet side
- The values of air volume are the mid-points of results measured by our company, within ±10% tolerance

Wiring Diagram

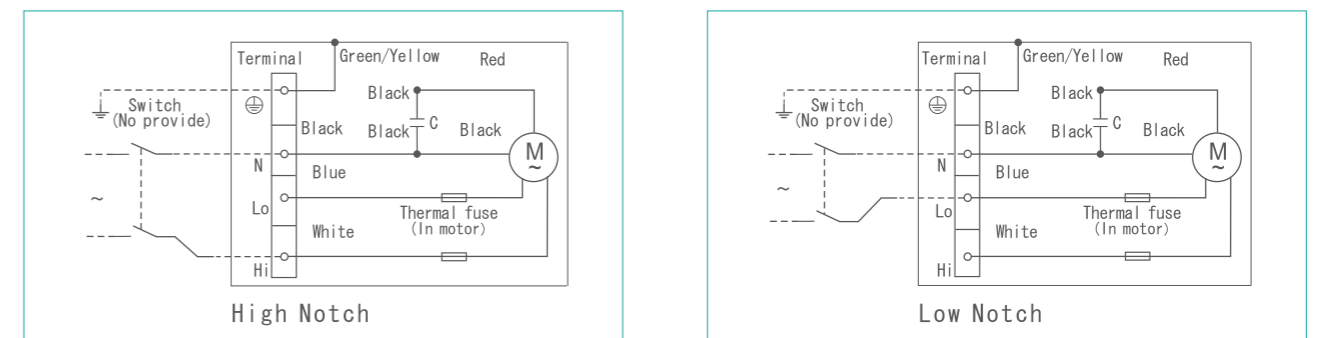

Standard Series

Usage: Living Room Shopping Mall Restaurant

20NSB / 23NLB

Sirocco Fan

Low Noise Design

Compact Size

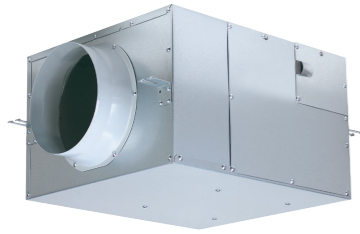

- Long life condenser motor with thermal cut-off
- Twin flow fan (sirocco fan)
- Fan casing with tapered scroll
- Embedded terminal box
- Noise absorption material adopted
- Motor insulation Class E
- IP protection: IPX2

Dimension
Unit : mm

Model	A	B	C	D	E	F	G	H	I
20NSB	416	376	441	485	272	136	195	211	70
23NLB	468	424	469	513	298	149	195	211	70

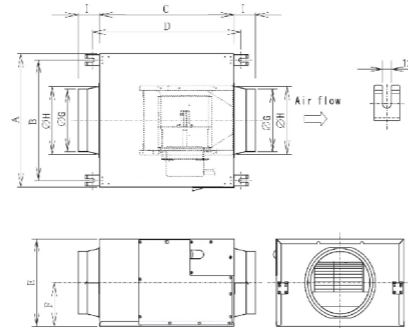

Specification

Model	Voltage [V]	Frequency [Hz]	Air Volume		Consumption [W]	Noise [dB(A)]	Weight [kg]	Duct Size [mm]	Impeller Diameter [mm]	
			[CMH]	[CFM]						
20NSB	220	50	Hi	920	541	120	14.0	Ø200	178	
			Lo	720	424	113				
		60	Hi	860	506	159				32
	Lo		620	365	128	26				
	230	50	Hi	930	547	125				33
			Lo	750	441	120				30
60		Hi	940	553	135	34				
	Lo	790	465	125	31					
23NLB	220	50	Hi	1,200	706	230	18.0	Ø200	220	
			Lo	900	530	170				34
		60	Hi	1,100	647	310				40
	Lo		800	471	190	32				
	230	50	Hi	1,200	706	250				40
			Lo	900	530	180				35
60		Hi	1,250	736	260	41				
	Lo	950	559	190	37					

Test Condition

- Air volume, electric characteristic and noise are specified at the static pressure of 0 Pa
- The values of noise level is A weighted average sound pressure level, the mean values are measured by our company, within +3 to -7 dB tolerance
- The values of noise level are measured at 1.5 m apart from the side of fan body when ducts are connected on outlet side
- The values of air volume are the mid-points of results measured by our company, within ±10% tolerance

Wiring Diagram

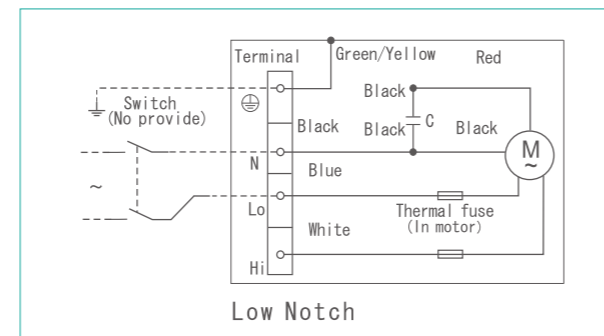
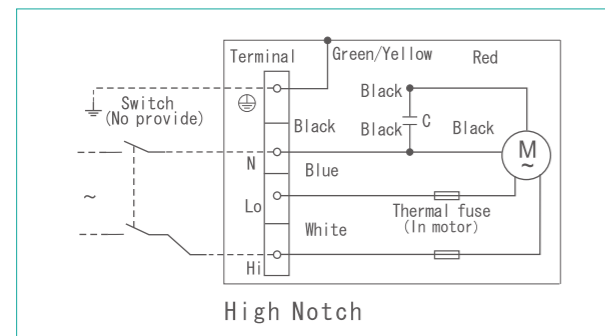

Standard Series

Usage: Living Room Shopping Mall Restaurant

25NSB / 25NFB

Sirocco Fan

Low Noise Design

Compact Size

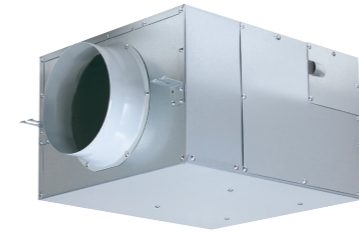

- Long life condenser motor with thermal cut-off
- Twin flow fan (sirocco fan)
- Fan casing with tapered scroll
- Embedded terminal box
- Noise absorption material adopted
- Motor insulation Class E
- IP protection: IPX2

Dimension
Unit : mm

Model	A	B	C	D	E	F	G	H	I
25NSB	494	450	505	549	334	167	240	255	85
25NFB	494	450	505	549	334	167	240	255	85

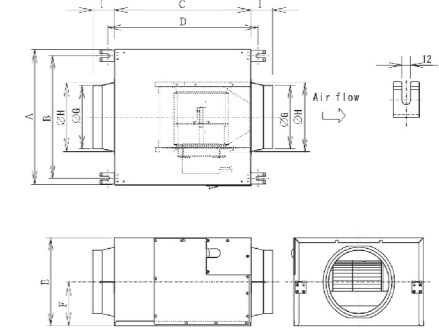

Specification

Model	Voltage [V]	Frequency [Hz]	Air Volume		Consumption [W]	Noise [dB(A)]	Weight [kg]	Duct Size [mm]	Impeller Diameter [mm]	
			[CMH]	[CFM]						
25NSB	220	50	Hi	1,700	1,001	345	24.0	Ø250	220	
			Lo	1,380	812	265				38
		60	Hi	1,650	971	425				41
	Lo		1,200	706	300	39				
	230	50	Hi	1,720	1,012	350				42
			Lo	1,380	812	270				39
60		Hi	1,750	1,030	370	44				
	Lo	1,450	853	290	40					
25NFB	220	50	Hi	1,900	1,118	390	24.0	Ø250	220	
			Lo	1,600	942	325				40
		60	Hi	1,810	1,065	520				42
	Lo		1,400	824	380	41				
	230	50	Hi	1,910	1,124	410				45
			Lo	1,600	942	335				41
60		Hi	1,920	1,130	430	46				
	Lo	1,620	953	360	42					

Test Condition

- Air volume, electric characteristic and noise are specified at the static pressure of 0 Pa
- The values of noise level is A weighted average sound pressure level, the mean values are measured by our company, within +3 to -7 dB tolerance
- The values of noise level are measured at 1.5 m apart from the side of fan body when ducts are connected on outlet side
- The values of air volume are the mid-points of results measured by our company, within ±10% tolerance

Wiring Diagram

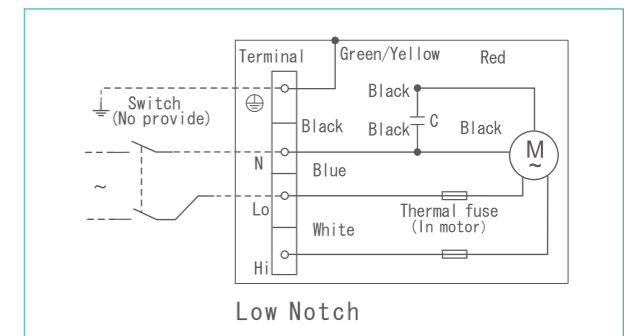
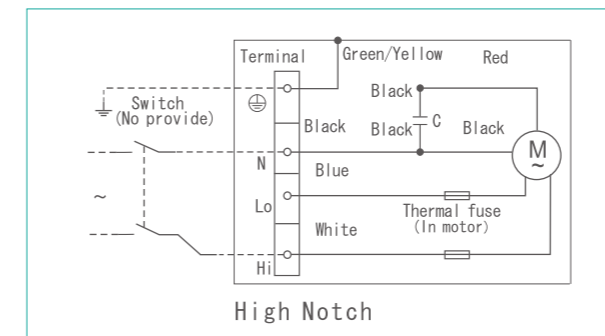

Standard Series

Usage: Living Room Shopping Mall Restaurant

25SWC / 25SMC

- Sirocco Fan
- Low Noise Design
- Compact Size



- Long life condenser motor with thermal cut-off
- Twin flow fan (sirocco fan)
- Fan casing with tapered scroll
- Embedded terminal box
- Noise absorption material adopted
- Motor insulation Class F
- IP protection: IPX2

Dimension

Unit : mm

Model	A	B	C	D	E	F	G	H	I
25SWC	809	496	1,010	1,052	942	246	185	370	766
25SMC	809	696	1,010	1,052	942	246	185	370	766

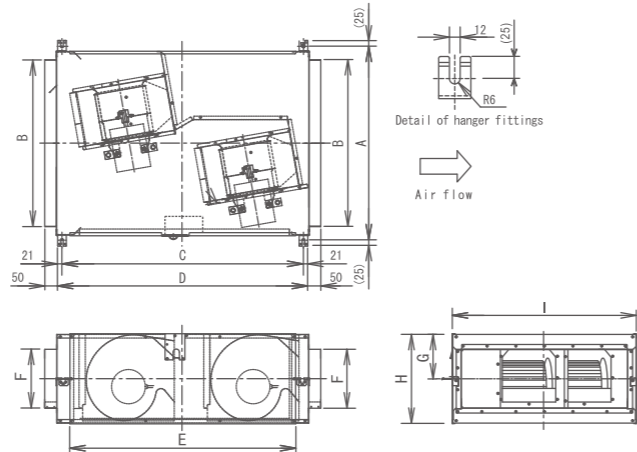

Specification

Model	Phase	Voltage [V]	Frequency [Hz]	Air Volume		Consumption [W]	RPM	Noise [dB(A)]	Weight [kg]	Duct Size [mm]	Impeller Diameter [mm]
				[CMH]	[CFM]						
25SWC	3	380	50	4,000	2,354	940	1,375	43	60	250 x 250	250
			60	4,500	2,648	1,450	1,530	45			
25SMC	3	380	50	5,200	3,060	1,180	1,345	45	60	250 x 700	250
			60	5,500	3,237	1,750	1,470	46			

Note:
 - The value in specification tables are representative characteristic value at 380V 50/60Hz.
 - RPM data is for reference only. Values may vary subject to different conditions.

Wiring Diagram

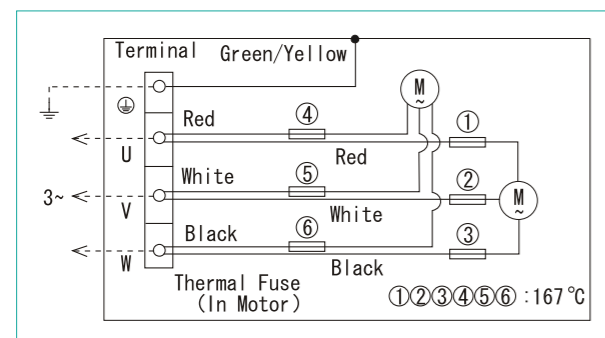

Standard Series

Usage: Living Room Shopping Mall Restaurant

28NXC

- Sirocco Fan
- Low Noise Design
- Compact Size

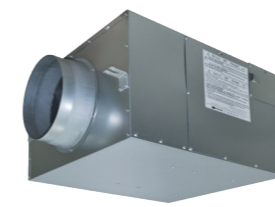

- Long life condenser motor with thermal cut-off
- Twin flow fan (sirocco fan)
- Fan casing with tapered scroll
- Embedded terminal box
- Noise absorption material adopted
- Motor insulation Class F
- IP protection: IPX2

Dimension

Unit : mm

Model	A	B	C	D	E	F	G	H	I
28NXC	554	510	557	601	342	171	240	255	85

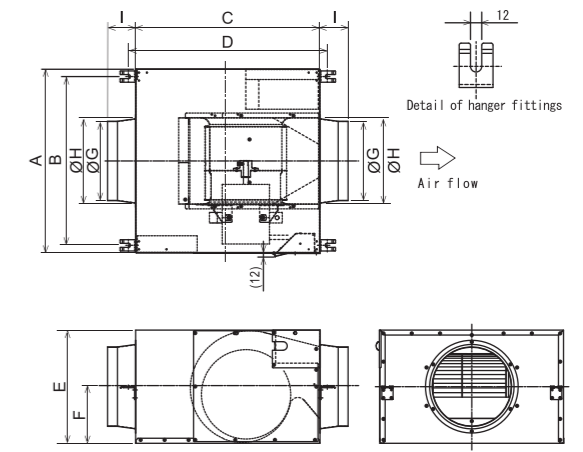

Specification

Model	Phase	Voltage [V]	Frequency [Hz]	Air Volume		Consumption [W]	RPM	Noise [dB(A)]	Weight [kg]	Duct Size [mm]	Impeller Diameter [mm]
				[CMH]	[CFM]						
28NXC	3	380	50	2,600	1,530	600	1,295	44	28	Ø250	280
			60	2,650	1,560	840	1,380	45			

Note:
 - The value in specification tables are representative characteristic value at 380V 50/60Hz.
 - RPM data is for reference only. Values may vary subject to different conditions.

Wiring Diagram

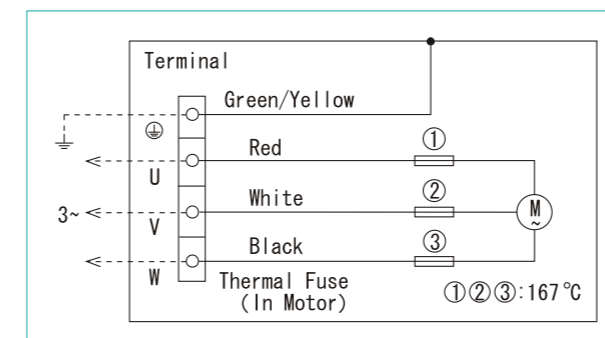

Mini Sirocco Fan



High Performance



Durable



Easy Installation



Scan for more information



Mini Sirocco Fan

More Compact

With the optimal air passage design, the body size is compact. It enables easy installation in narrow and limited space environment.

Higher Duct Connectivity

After the improvement on the adapter design, the duct connectivity is enhanced with the extended adapter.

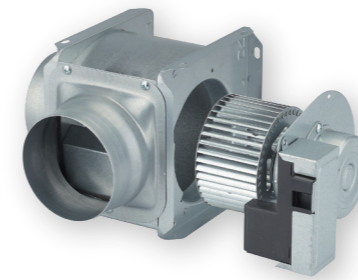
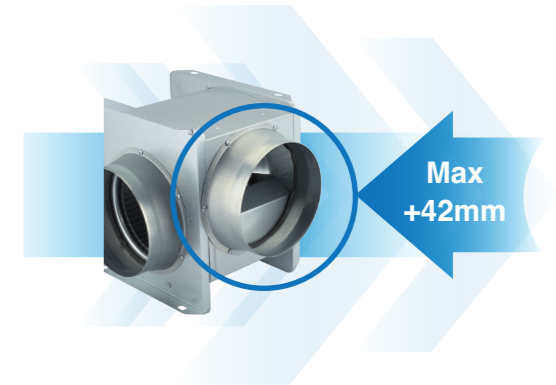

Simplified Maintenance

By unitizing the fan and motor as one single unit, the impeller can be replaced and cleaned without removing the duct. It facilitates more user-friendly maintenance.

Easy Installation

The inlet and outlet of the sirocco fan are of the same size for easy connection to a ducted system. The fan can be mounted on the ceiling.

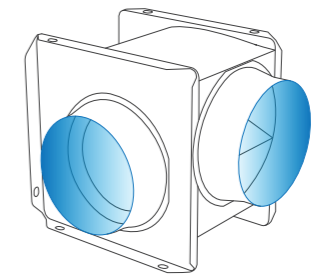

Adjustable Outlet Direction

With the mounting feet on the fan body, installation has become easier. Outlet direction is adjustable to fit vertical or horizontal position.

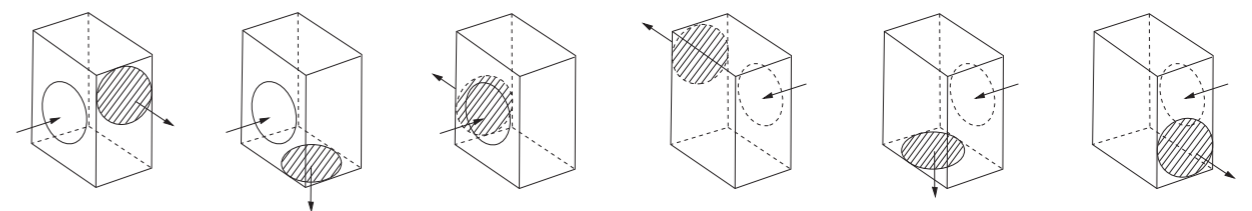

Various installing patterns satisfy different installation space

Mini Sirocco Fan

Usage: Locations where high air volume is needed

10CGB / 12CGB / 14CGB
16CGB / 17CGB / 19CGB / 21CGB

- Optimal Air Passage
- High Duct Connectivity
- Easy Installation

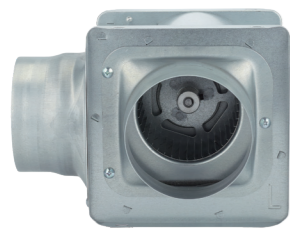

- Forward curve fan
- Galvanized steel
- Compact size for narrow space installation
- Extended adapter for higher connectivity
- Long life induction motor with thermal cut-off
- Well-lubricated ball bearing for long life operation
- Highly efficient sirocco fan designed for powerful airflow
- Outlet direction adjustable to vertical or horizontal position
- Motor IP rating:
Class E for 10CGB, 12CGB, 14CGB, 16CGB, 17CGB & 19CGB
Class F for 21CGB
- Insulation class: IPX2

Wiring Diagram

- Wiring connection when not use speed switch.

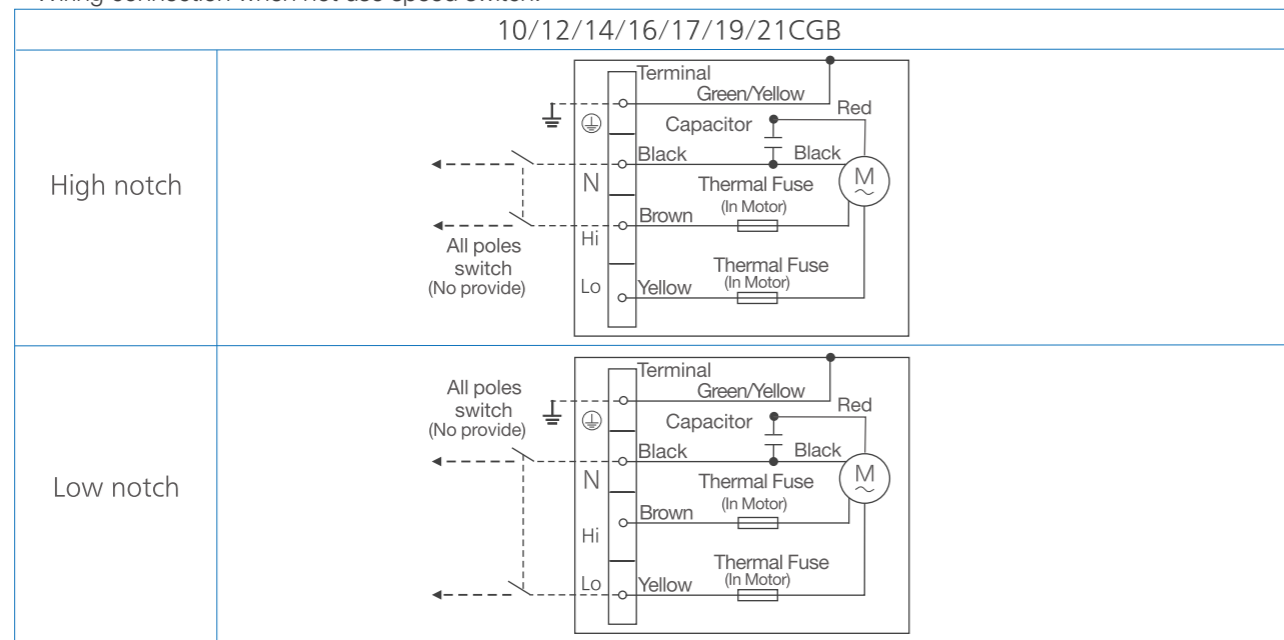

- Wiring connection when use speed switch.

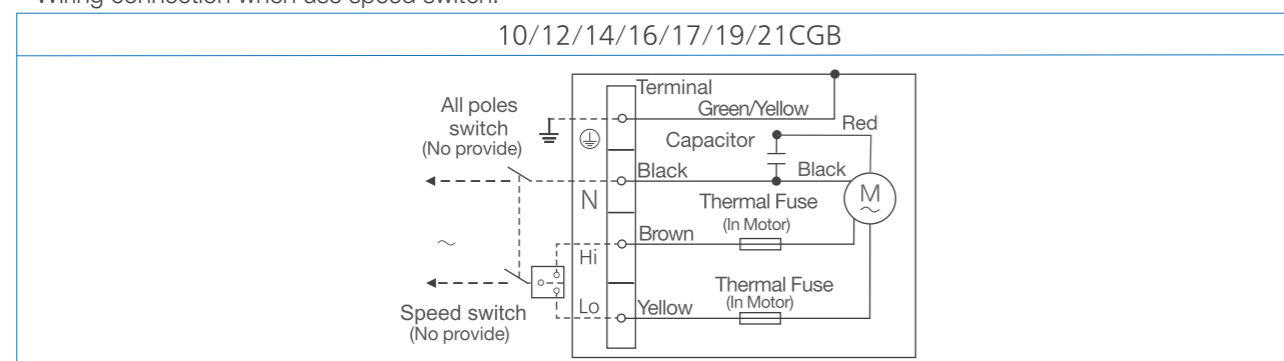

Dimensions Unit: mm

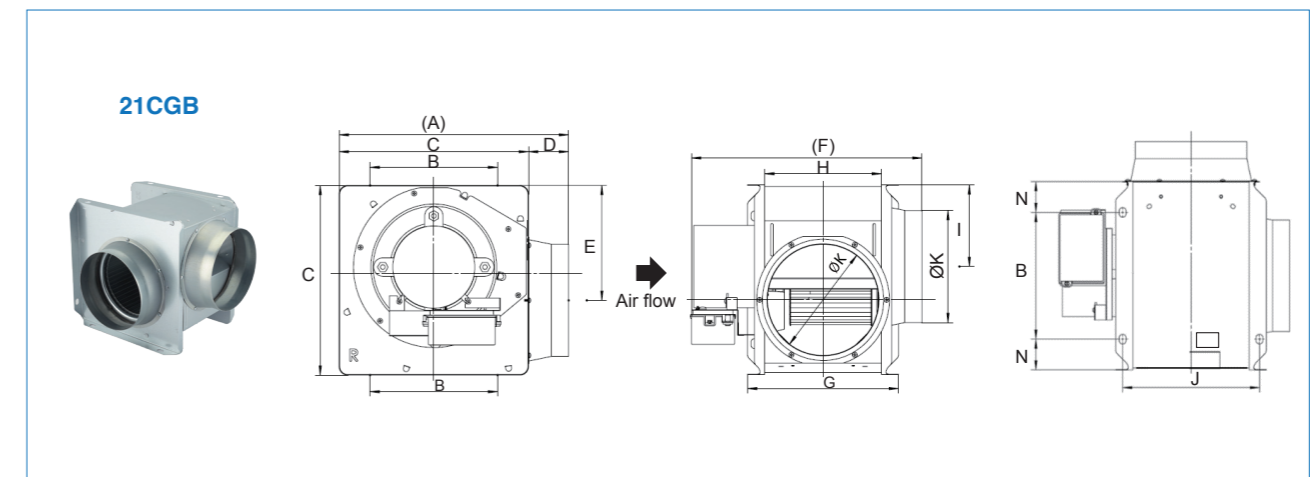
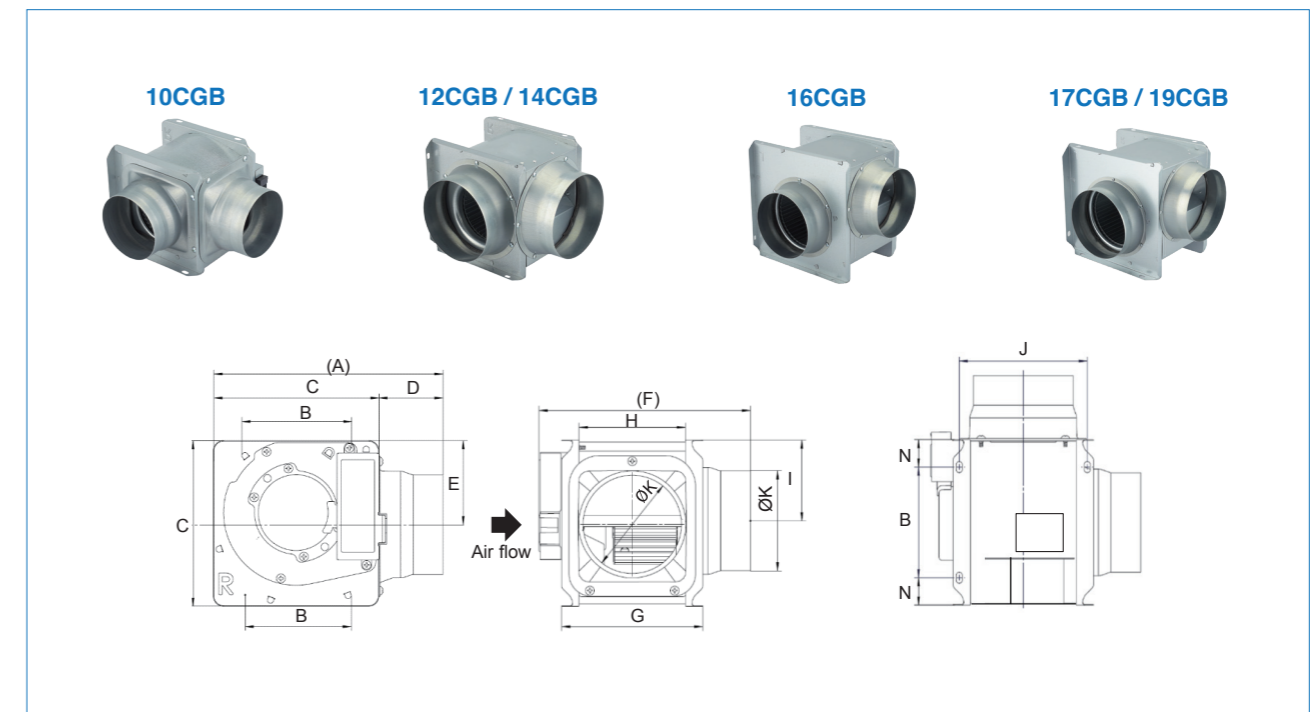

Model	A	B	C	D	E	F	G	H	I	J	K	N	Connector Duct Dimension (mm)
10CGB	226	109	163	63	83	207	138	104	79	126	98	27	Ø100
12CGB	269	145	209	60	112	236	170	136	101	158	146	32	Ø150
14CGB													
16CGB	330	196	270	60	170	264	189	155	117	177	146	37	Ø150
17CGB	400	222	330	71	200	332	263	203	142	239	195	55	Ø200
19CGB													
21CGB	400	222	330	71	200	403	263	203	142	239	195	55	Ø200

Specification

Model	Voltage [V]	Frequency [Hz]	Speed	Air Volume [CMH]	Consumption [W]	Noise Level [dB]		Net Weight [kg]
						Inlet	Side	
10CGB	220	50	Hi	154	15	41.0	28.0	1.9
			Lo	115	12	35.5	24.0	
		60	Hi	133	12	36.5	24.0	
			Lo	93	9	28.5	20.0	
	230	60	Hi	143	13	38.0	25.0	
			Lo	100	10	30.5	20.0	
	220-240	50	Hi	134-143	10-11	37.0-39.0	23.0-25.0	
			Lo	110-125	9-10	32.0-35.0	20.0-23.0	
12CGB	220	50	Hi	250	22	44.0	29.0	2.5
			Lo	175	16	32.0	19.0	
		60	Hi	225	25	42.5	29.0	
			Lo	145	18	32.0	21.0	
	230	60	Hi	242	27	44.0	30.0	
			Lo	153	19	34.0	21.5	
	220-240	50	Hi	233-262	23-28	44.5-46.5	29.0-32.0	
			Lo	156-175	19-23	33.0-36.0	18.0-20.0	
14CGB	220	50	Hi	332	35	50.0	34.0	2.8
			Lo	226	28	40.0	26.0	
		60	Hi	260	30	43.0	30.0	
			Lo	200	25	35.5	25.0	
	230	60	Hi	275	33	44.5	31.5	
			Lo	212	28	37.5	26.0	
	220-240	50	Hi	280-315	28-32	44.5-46.5	31.0-33.0	
			Lo	227-265	26-30	40.0-44.0	27.0-31.0	
16CGB	220	50	Hi	509	50	49.0	35.0	5.6
			Lo	405	43	43.5	30.0	
		60	Hi	483	57	48.0	32.0	
			Lo	372	44	41.0	27.0	
	230	60	Hi	503	61	49.0	34.5	
			Lo	393	48	42.5	29.0	
	220-240	50	Hi	509-542	50-56	49.0-51.5	35.0-38.0	
			Lo	405-450	43-48	43.5-46.0	30.0-32.0	

Specification

Model	Voltage [V]	Frequency [Hz]	Speed	Air Volume [CMH]	Consumption [W]	Noise Level [dB]		Net Weight [kg]
						Inlet	Side	
17CGB	220	50	Hi	791	86	50.0	36.0	10.1
			Lo	640	70	44.0	31.0	
		60	Hi	752	95	49.0	34.0	
			Lo	612	73	43.5	29.0	
	230	60	Hi	789	104	50.0	35.0	
			Lo	641	80	44.0	31.0	
	220-240	50	Hi	791-875	86-101	50.0-52.5	36.0-39.0	
			Lo	640-705	70-83	44.0-47.0	31.0-32.0	
19CGB	220	50	Hi	947	121	55.0	41.0	10.2
			Lo	857	105	51.5	37.0	
		60	Hi	885	127	52.0	39.0	
			Lo	760	107	48.0	37.0	
	230	60	Hi	931	140	53.5	40.0	
			Lo	791	117	49.5	36.5	
	220-240	50	Hi	919-997	113-130	52.0-54.0	40.0-42.0	
			Lo	804-880	99-115	50.0-52.0	38.0-40.0	
21CGB	220	50	Hi	1420	238	67.0	54.0	14.6
			Lo	1143	182	60.0	47.0	
		60	Hi	1500	328	68.0	57.0	
			Lo	1042	215	58.0	47.0	
	230	60	Hi	1550	342	69.0	57.5	
			Lo	1100	230	59.5	48.0	
	220-240	50	Hi	1420-1435	238-247	66.0-67.0	54.0-55.0	
			Lo	1143-1220	182-197	60.0-62.5	47.0-51.0	

Notes:

- ① The values of rated input, air volume and noise are specified at the static pressure of 0 Pa.
- ② The values of noise level is A weighted average sound pressure level, the mean values are measured by our company, within +3 and -7 tolerance.
- ③ The values of noise level are measured at the 1.5m apart from the inspection panel of the fan body when ducts are connected on both inlet and outlet side. It is based on the assumption that the noise of fan body propagates to room inside.
- ④ The values of air volume are the mid-points of results measured by our company, with ±10% tolerance.

Accessories - Pipe Hood

MGX100K / MGX150K MCX100K / MCX150K



Dimension
Unit : mm

Model	A	B	C	D	E
MGX100K	141	79	20	97	48
MGX150K	190	106	23	147	53
MCX100K	141	79	20	97	48
MCX150K	190	106	23	147	53

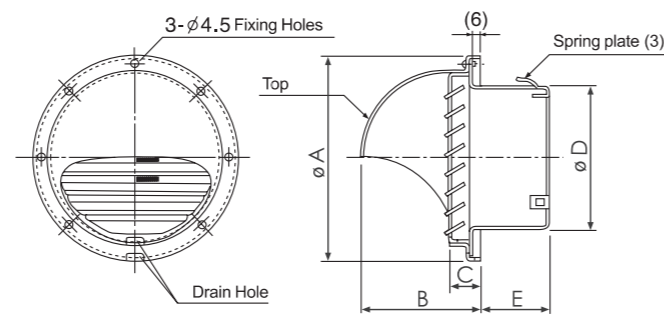

- High strength - adopt 0.5mm thickness SUS 304 Stainless steel
- Excellent anti-rust capability - hood part coated with metallic silver paint prevents oxidation of material
- Easy installation - 3pcs of spring clip facilitate duct/pipe connection
- 2.5x2.5mm net keep out ingress of small particles and insects from outside (MGX100K & MGX150K)
- It is recommended to use pipe hood with net at intake terminal while with-out net at exhaust

Specification

Model	Diameter of Applicable Pipe [mm]	Material	Dimension of Net [mm]
MGX100K	100	Stainless Steel	2.5 x 2.5
MGX150K	150	Stainless Steel	2.5 x 2.5
MCX100K	100	Stainless Steel	-
MCX150K	150	Stainless Steel	-

Accessories - Vent Cap

VGX100K / VGX150K VCX100K / VCX150K



Dimension
Unit : mm

Model	A	B	C	D	E
VGX100K	120	97	145	13	47
VGX150K	169	149	195	18	52
VCX100K	120	97	145	13	47
VCX150K	169	147	195	18	52

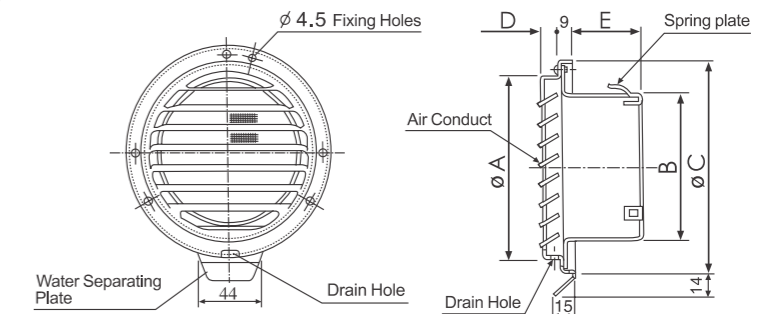

- High strength and excellent anti-rust capability - adopt 0.5mm thickness SUS 304 Stainless steel
- Easy installation - 3pcs of spring clip facilitate duct/pipe connection
- 2.5x2.5mm net keep out ingress of small particles and insects from outside (VGX100K & VGX150K)
- It is recommended to use pipe cap with net at intake terminal while with-out net at exhaust

Specification

Model	Diameter of Applicable Pipe [mm]	Material	Dimension of Net [mm]
VGX100K	100	Stainless Steel	2.5 x 2.5
VGX150K	150	Stainless Steel	2.5 x 2.5
VCX100K	100	Stainless Steel	-
VCX150K	150	Stainless Steel	-

Energy Recovery Ventilator



24-Hour Ventilation



Energy Saving



Filtration



Powerful

Energy Consumption Demand

There is a significant increase in the energy consumption demand globally, which is illustrated as in below charts.

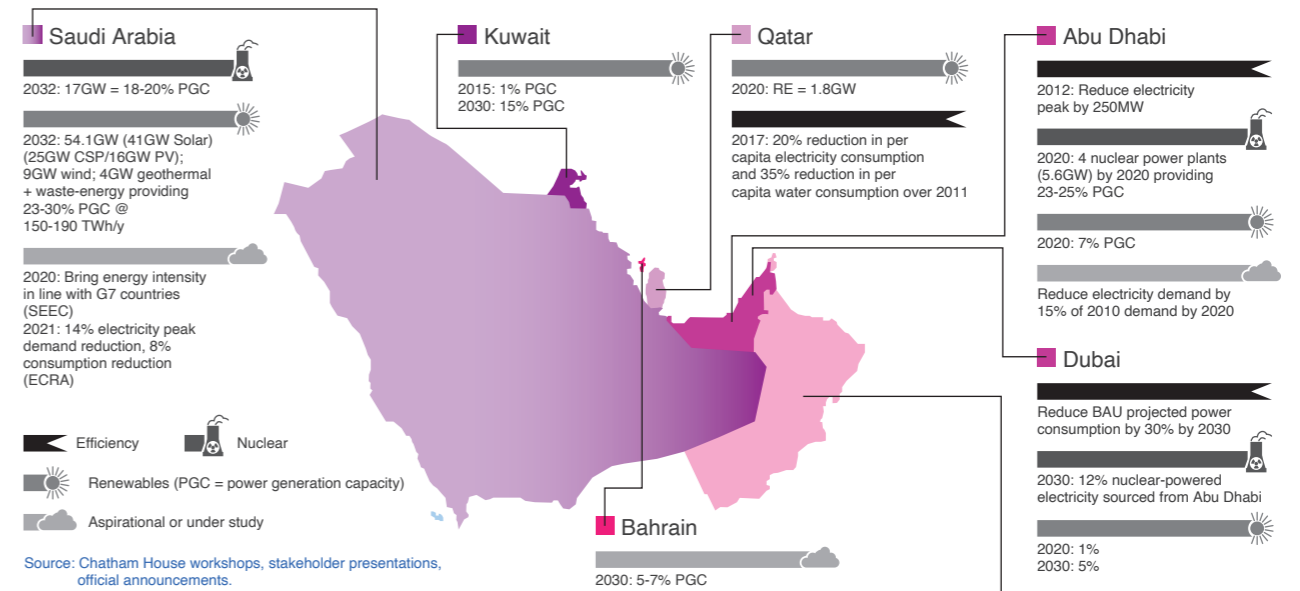
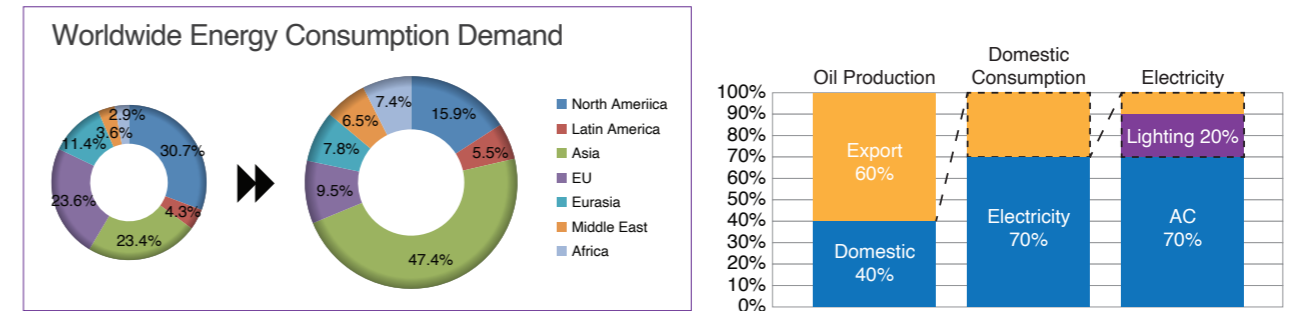

New Energy Saving Regulation "World Top Regulation (EER > 9.5 at T1 condition)"

Y2013 Feb	: DEWA Gov. Announced New Regulation (From 2015)
Y2013 May	: Oil Gov. Announced to Move up the Schedule (From 2014)
(Phase-1)	
Y2013 Sep	: Banned to Import / Manufacture Non-Conformity Products
Y2014 Jan	: Banned to Import / Manufacture Non-Conformity Products
(Phase-2)	
Y2015 Jan	: Regulation becomes more strict (Required for EER>11.5)

Energy Saving Label Regulation

Significant energy saving could be achieved by using energy efficient appliances which help reducing the emission of greenhouse gases and other air pollutants from the power plants. To further facilitate the public in choosing energy efficient appliances and to raise public awareness on energy saving, Energy Labelling Schemes have been introduced.

Jordan



South Africa

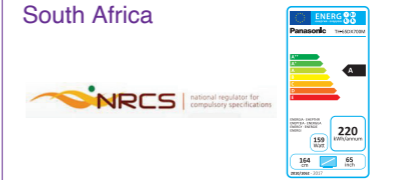

UAE



Egypt



Iran



Saudi Arabia



Scan for more information



Feature of Energy Recovery Ventilator

KDK Energy Recovery Ventilator is equipped with heat exchange core element. When outdoor fresh air and indoor foul air pass through the heat exchange core element, heat carried by the air is exchanged through air flow and heat conduction at the heat transfer sheets. Meanwhile, humidity exchange occurs from high humidity to low humidity as moisture is transferred due to the difference in pressure of water vapour.

Energy Saving

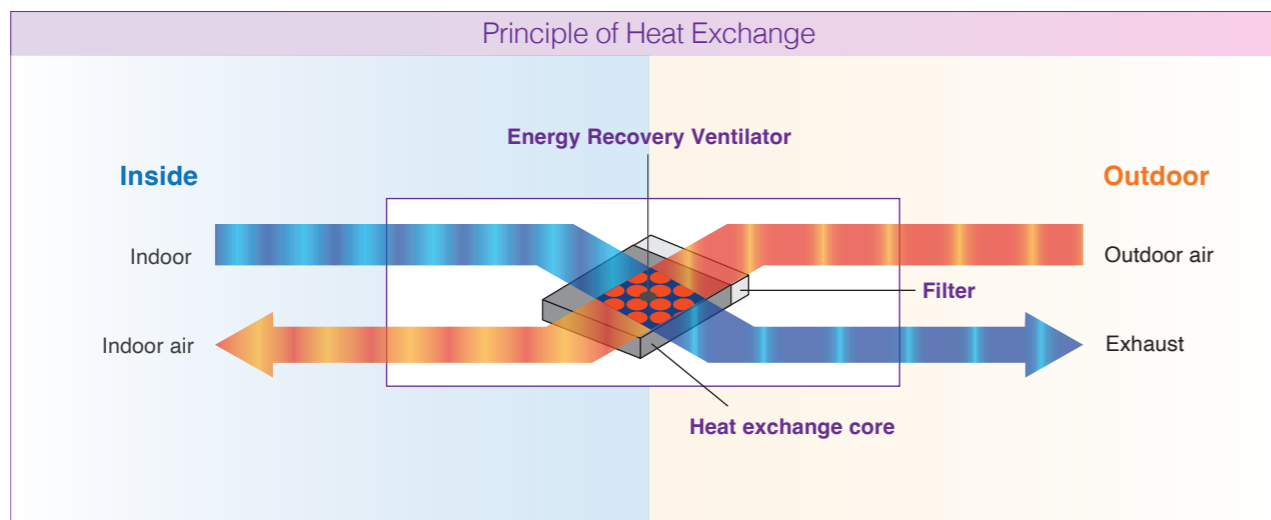
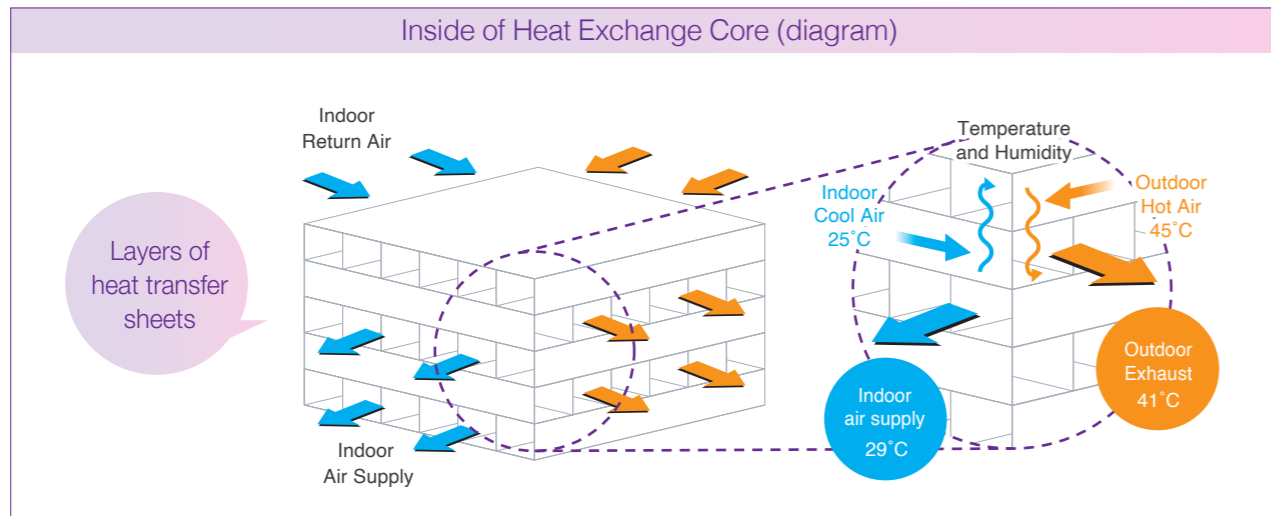

Summer

In summer, the indoor cool air discharged can be used to precool outdoor warm air before it gets delivered indoor and so reduces the cooling effort.

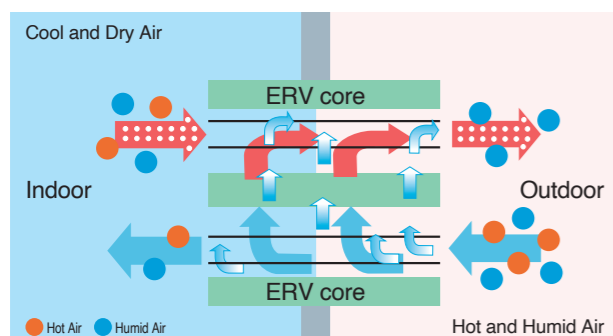

Winter

Whereas in winter, indoor warm air discharged can be used to preheat outdoor cool air before it is released indoor and so saves some energy of heating.

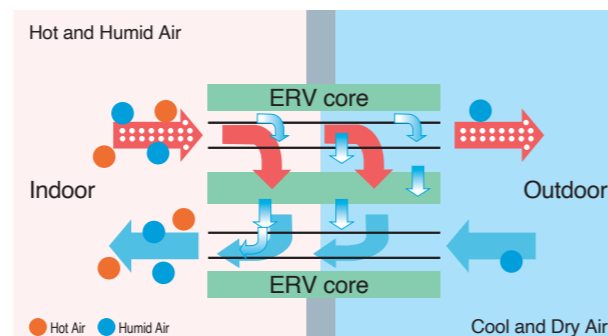

Cost Efficient

Highly efficient energy recovery reduces energy loss during ventilation, and hence achieves energy saving.

Long Term Energy Consumption Comparison

Comparison of the energy consumption over 180 days between using energy recovery ventilator and ventilating fan, in cooperation with air conditioning.

Summer By utilizing the returned indoor cool air to cool down the outdoor air before it enters indoor, the indoor cooling cost can be reduced.

Power Consumption of Fan and Air Conditioning

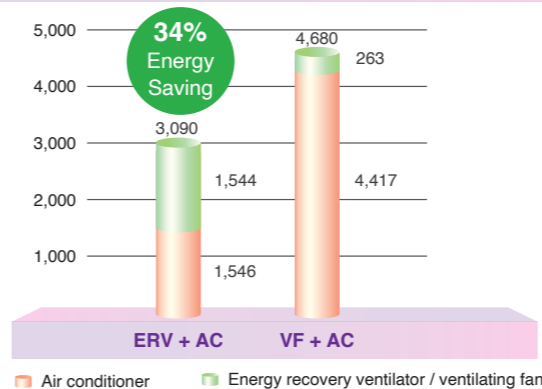

Based on the following condition

Simulation place: Aug Riyadh Saudi Arabia
 Room Area = 210 m²
 Room Height = 3 m
 Required Air Volume = 315 CMH
 A/C system running time : 2700h = 15h/day * 180day (May-Oct)
 ERV : E35DZUA (2unit) 282W*2 = 564W
 V-Fan : General (6unit) 48W*6 = 288W

Energy Recovery Ventilation + Air Conditioning

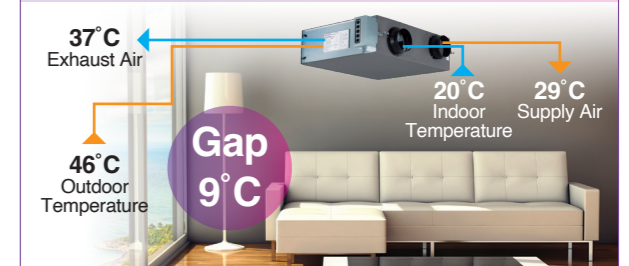

Normal Ventilation + Air Conditioning



Energy saving while holding down the air-conditioning cost



ERV can pre-cool (in summer) or pre-heat (in winter) the incoming air through the heat exchange mechanism with the outgoing air. This can largely save the cost of indoor air conditioning.

Keeping comfortable indoor temperature regardless the condition outdoor



When it is cold outside, the incoming air is preheated by the outgoing warmed air before entering indoor.



When it is hot outside, the incoming air is pre-cooled by the outgoing cooled air before entering indoor.

Aiding effective soundproof



Energy recovery ventilator operates in an airtight indoor environment while keeping high performance of ventilation. As a result, indoor sound like night music and video can be enjoyed without worrying sound leakage to the outside.



Likewise, airtight houses can effectively block the noise from outside entering indoor while energy recovery ventilator keeps up high performance of ventilation.

Filter Box Specially for Middle East Region to Bring You Clean Air

KDK filter box is part of the ERV designed to make the indoor spaces insect free, dustproof and pollen free, such that fresh air can be circulated.

There are two filters, Primary Filter and PM2.5 Filter in one box. Incoming air firstly passes through Primary Filter which filters large particles like sand and insect. Then the tiny and invisible particles are further trapped by PM2.5 Filter. The ERV can bring you clean, fresh and comfortable air with these two layers of filters.

Filter Box

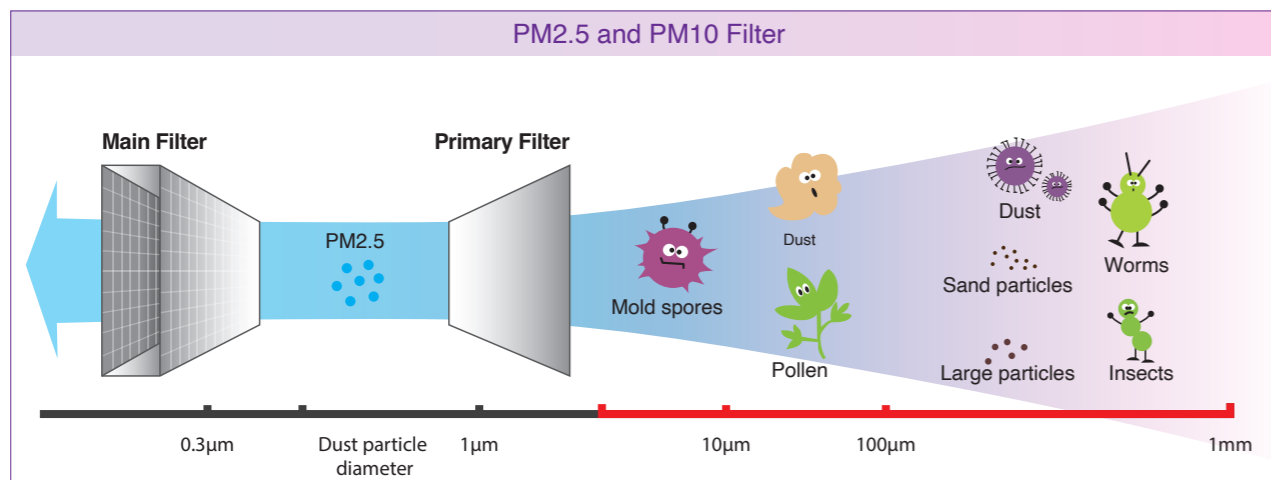
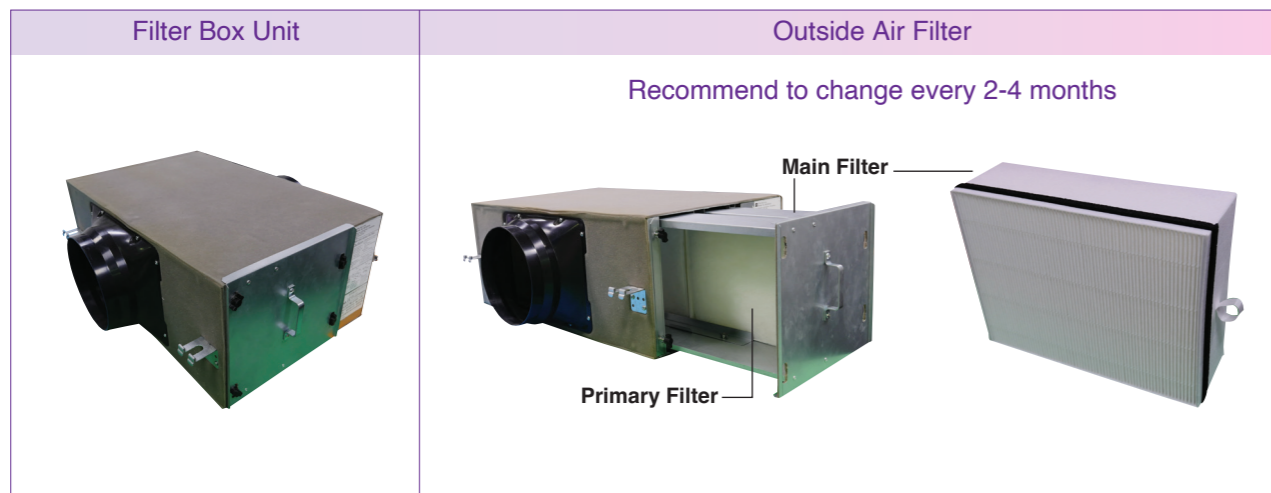

Filter Efficiency - Effectively capture PM2.5 and PM10 particles to deliver clean air to indoor

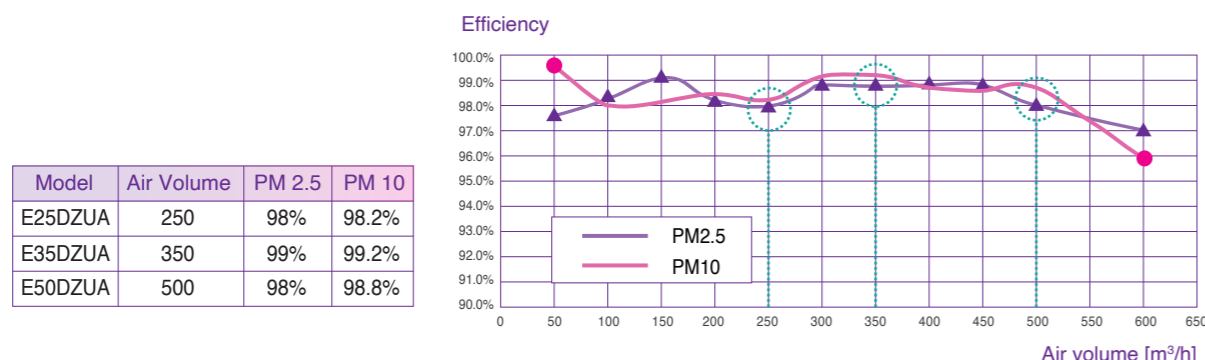

Dust Polluted Air in Riyadh

Comparison of the particle size distribution of air dust (At a House in Riyadh)

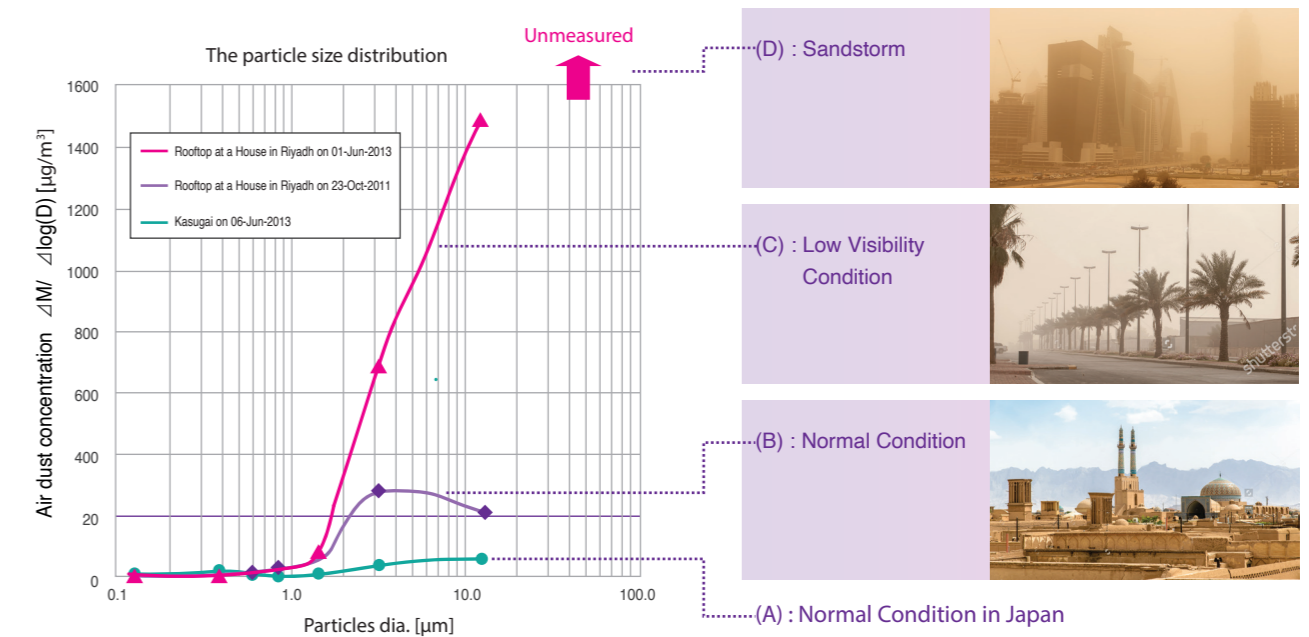

Field test result in Saudi Arabia

Sand dust carries large number of 2-10 micrometre particles. KDK ERV is well equipped with filter box specially designed for Middle East environment.



Ignition Loss Test* result in Saudi Arabia

Large particle can be effectively trapped by the filter. There are many pollutants can be obtained by filters.

Filter Type	Collection amount (g)	Moisture (%)	Inorganic matter (%)
Standard Pre-filter	13.2	2.5	60.7
PM 2.5 Filter	2.5	3.0	61.7

* Test Period: 2014/11/04~2014/12/15 Test Filter: FY-FBG25C

Standard Series

Usage: Living Room Shopping Mall Office

E25DZUA

Energy Exchange

Speedy Exhaust

Interlocking with A/C



- Counter-flow heat-exchange element adopted for compact size
- Ease of maintenance through a single inspection hole
- Equipped with Extra-High setting
- Bypass ventilation for speedy exhaust
- Interlocking with air conditioning
- Motor insulation Class E
- IP protection: IPX2

Specification

Model	Voltage [V]	Frequency [Hz]	Notch	Air Volume		Consumption [W]	External Static Pressure [Pa]	Exchange Efficiency				Noise [dB(A)]	Weight [kg]
				[CMH]	[CFM]			Temperature Cooling	Temperature Heating	Enthalpy Cooling	Enthalpy Heating		
E25DZUA	220	60	SH	250	147	157	90	60	75	61	67	33	30
			H	250	147	148	40	60	75	61	67	33	
			L	150	88	82	0	65	77	70	74	26	

Test Condition

- The input power, current and exchange efficiency are measured at the standard air volume
- The input power indicated in name plate is the maximum value at the static pressure of 0 Pa
- The noise is measured 1.5 m away from the bottom face of the unit. The noise value measured at the total acoustic room is more than the indicated value in actual operation
- The above parameters are measured according to standard JIS B 8628

Dimension Unit : mm

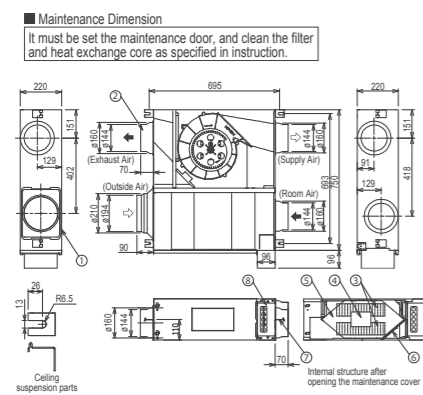

No.	Part name	Qty	Material
1	Frame	1	Galvanized Steel Sheet
2	Adapter	4	ABS
3	Impeller	2	PP
4	Fan Motor	1	/
5	Heat Exchange Core	1	Special Paper and Resin
6	Indoor Filter	1	/
7	Ceiling Suspension	4	Galvanized Steel Sheet
8	Switch Box	1	Galvanized Steel Sheet
9	Filter Box Unit	-	/

Wiring Diagram

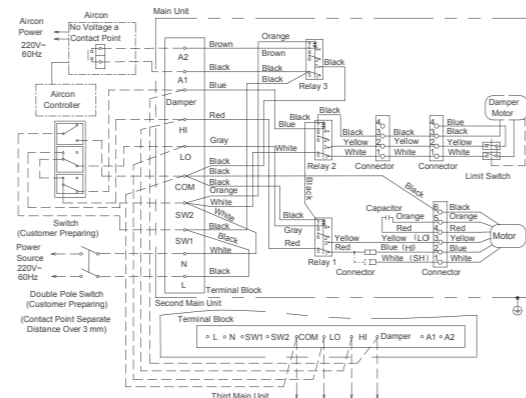

Installation method for case 1

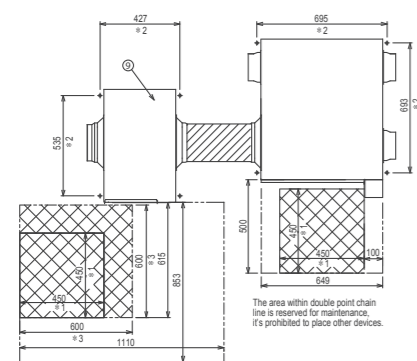

Installation method for case 2

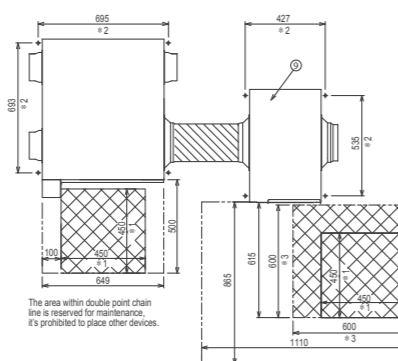

Standard Series

Usage: Living Room Shopping Mall Office

E35DZUA

Energy Exchange

Speedy Exhaust

Interlocking with A/C

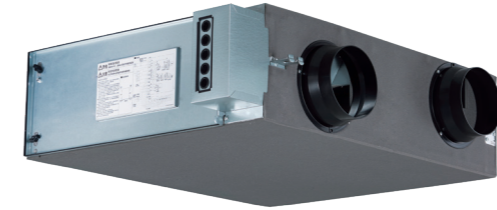

- Counter-flow heat-exchange element adopted for compact size
- Ease of maintenance through a single inspection hole
- Equipped with Extra-High setting
- Bypass ventilation for speedy exhaust
- Interlocking with air conditioning
- Motor insulation Class E
- IP protection: IPX2

Specification

Model	Voltage [V]	Frequency [Hz]	Notch	Air Volume		Consumption [W]	External Static Pressure [Pa]	Exchange Efficiency				Noise [dB(A)]	Weight [kg]
				[CMH]	[CFM]			Temperature Cooling	Temperature Heating	Enthalpy Cooling	Enthalpy Heating		
E35DZUA	220	60	SH	350	206	282	100	53	78	66	71.5	37	39
			H	350	206	253	18	53	78	66	71.5	36.5	
			L	255	150	172	0	53	75	63	70	30.5	

Test Condition

- The input power, current and exchange efficiency are measured at the standard air volume
- The input power indicated in name plate is the maximum value at the static pressure of 0 Pa
- The noise is measured 1.5 m away from the bottom face of the unit. The noise value measured at the total acoustic room is more than the indicated value in actual operation
- The above parameters are measured according to standard JIS B 8628

Dimension Unit : mm

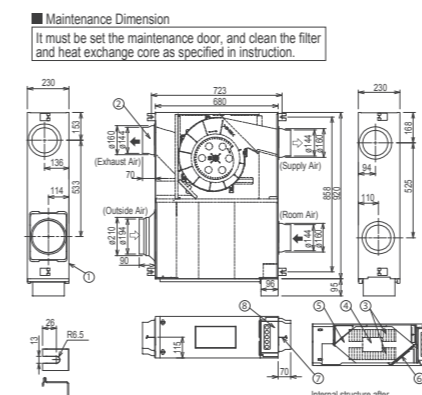

No.	Part name	Qty	Material
1	Frame	1	Galvanized Steel Sheet
2	Adapter	4	ABS
3	Impeller	2	PP
4	Fan Motor	1	/
5	Heat Exchange Core	1	Special Paper and Resin
6	Indoor Filter	1	/
7	Ceiling Suspension	4	Galvanized Steel Sheet
8	Switch Box	1	Galvanized Steel Sheet
9	Filter Box Unit	-	/

Wiring Diagram

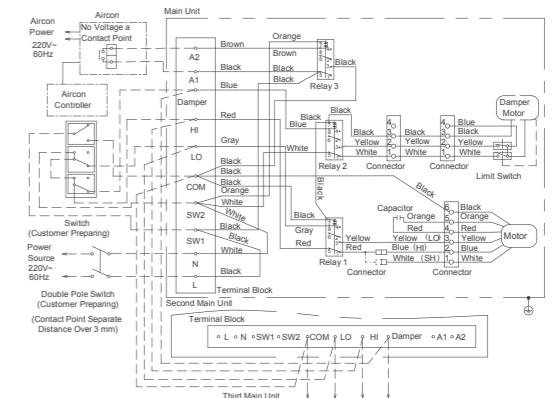

Installation method for case 1

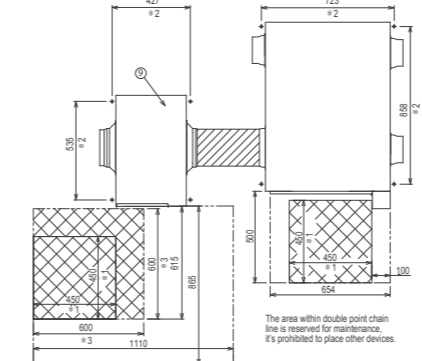

Installation method for case 2

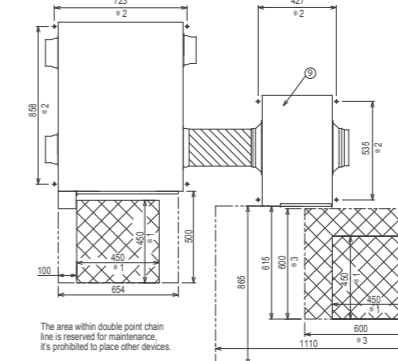

Standard Series

Usage: Living Room Shopping Mall Office

E50DZUA

Energy Exchange

Speedy Exhaust

Interlocking with A/C



- Counter-flow heat-exchange element adopted for compact size
- Ease of maintenance through a single inspection hole
- Equipped with Extra-High setting
- Bypass ventilation for speedy exhaust
- Interlocking with air conditioning
- Motor insulation Class E
- IP protection: IPX2

Specification

Model	Voltage [V]	Frequency [Hz]	Notch	Air Volume		Consumption [W]	External Static Pressure [Pa]	Exchange Efficiency				Noise [dB(A)]	Weight [kg]
				[CMH]	[CFM]			Temperature Cooling	Temperature Heating	Enthalpy Cooling	Enthalpy Heating		
E50DZUA	220	60	SH	500	294	376	60	53	78	66	70	38	45
			H	500	294	349	0	53	78	66	70	37.5	
			L	350	206	215	0	58	78	66	69	32	

Test Condition

- The input power, current and exchange efficiency are measured at the standard air volume
- The input power indicated in name plate is the maximum value at the static pressure of 0 Pa
- The noise is measured 1.5 m away from the bottom face of the unit. The noise value measured at the total acoustic room is more than the indicated value in actual operation
- The above parameters are measured according to standard JIS B 8628

Dimension Unit : mm

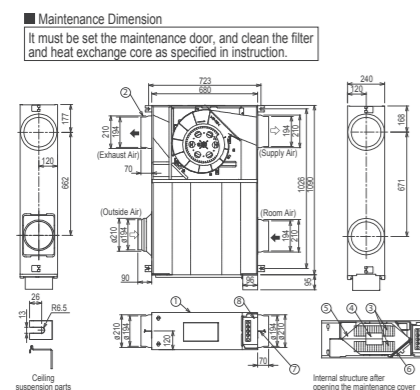

No.	Part name	Qty	Material
1	Frame	1	Galvanized Steel Sheet
2	Adapter	4	ABS
3	Impeller	2	PP
4	Fan Motor	1	/
5	Heat Exchange Core	2	Special Paper and Resin
6	Indoor Filter	1	/
7	Ceiling Suspension	4	Galvanized Steel Sheet
8	Switch Box	1	Galvanized Steel Sheet
9	Filter Box Unit	-	/

Wiring Diagram

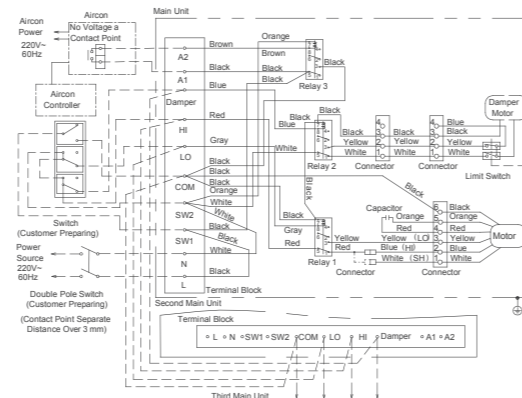

Installation method for case 1

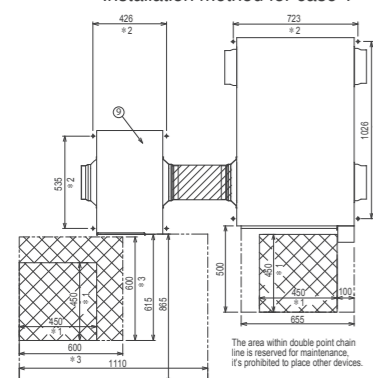

Installation method for case 2

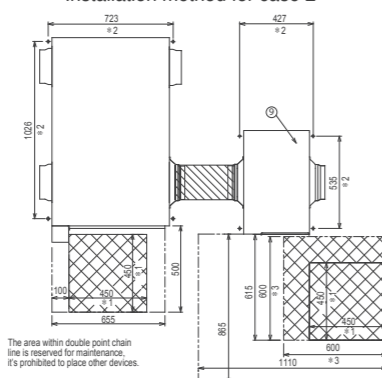

Accessory

EB90SA (Applicable to series DZUA)

- Power : 220V / 60Hz
- Rate voltage : 3.6W
- Outer size : 86x86x40mm



Filter Box Unit

BE25DZUA For E25DZUA, E35DZUA

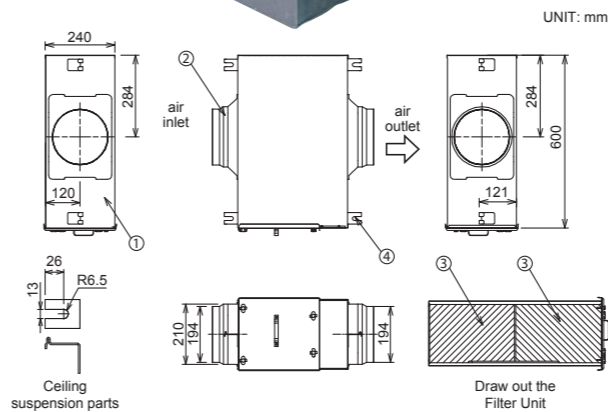
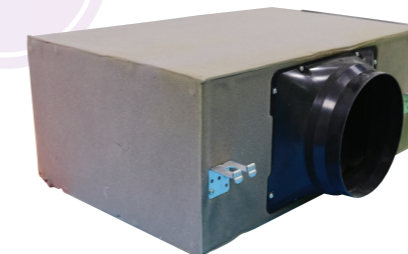

No.	Part name	Qty	Material
1	Frame	1	Galvanized Steel Sheet
2	Adapter	2	ABS
3	Outdoor filter	2	Nonwoven Fabric
4	Ceiling Suspension	4	Galvanized Steel Sheet

BE50DZUA For E50DZUA

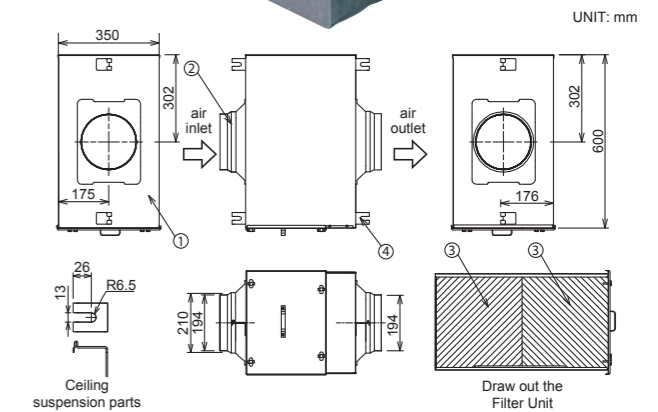
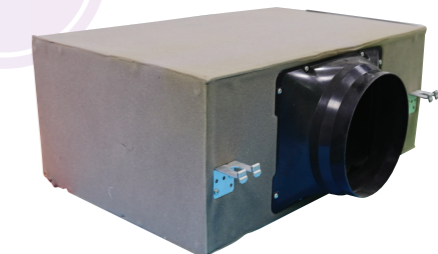

No.	Part name	Qty	Material
1	Frame	1	Galvanized Steel Sheet
2	Adapter	2	ABS
3	Outdoor filter	2	Nonwoven Fabric
4	Ceiling Suspension	4	Galvanized Steel Sheet

Replacement Filter

Product name	Filter Model	Filter(s) Included	Applicable Model	Service life of the filter	Remarks
Replacement filter for Filter Box Unit	FP25DZUA	2	BE25DZUA	2-4 months	Clean monthly
	FP50DZUA	2	BE50DZUA		
Replacement filter for ERV	FB25DZUA	1	E25DZUA	6 months	
	FB35DZUA	1	E35DZUA		
	FB50DZUA	1	E50DZUA		

- The service life of the filters varies with service environment, and the filters should be replaced with the new one.
- The air volume and filter efficiency will drop to different levels because of different service environments and service time. If the whole area indicated by the arrow turns black, please replace the filter.

Thermo Ventilator

Feature of Thermo Ventilator

Multi-functional

- Ventilation** - Exhaust foul smell and excessive moisture
- Circulation** - Provide circulation of air to avoid uncomfortable feeling due to stagnant air
- Heating** - Warm up the room for pleasant bathing
- Clothes Drying** - Enable to dry large sized garments and bedclothes.



Ventilation



Circulation

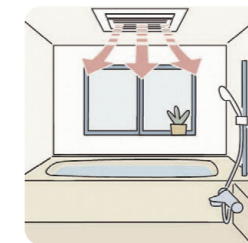

Heating



Clothes Drying

Remote Control

All functions can be operated through wireless remote control.

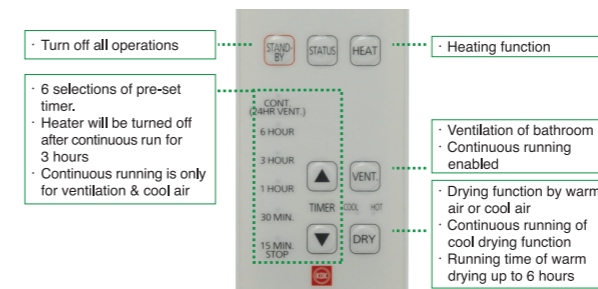

Filter Equipped

Equipped with dust filter to trap the dust.



Safety Protection

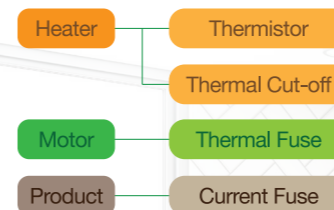

Multi-level safety structure protects you and your property from any accidents

Easy Installation

Specially designed compact size allows easy installation on most households' ceilings.

Structure is improved for easy wiring as compared with previous model.



Scan for more information



Ceiling Mount Series

Usage: Bathroom Toilet

30BUC

- Multi-functional
- Wireless Remote
- Compact Design



- Multi-function: Ventilation, Circulation, Heating and Clothes Drying
- PTC heating element for effective heating
- Multi-level safety protection
- 5-step off timer
- Motor insulation Class E
- IP protection: IPX2

Dimension Unit : mm

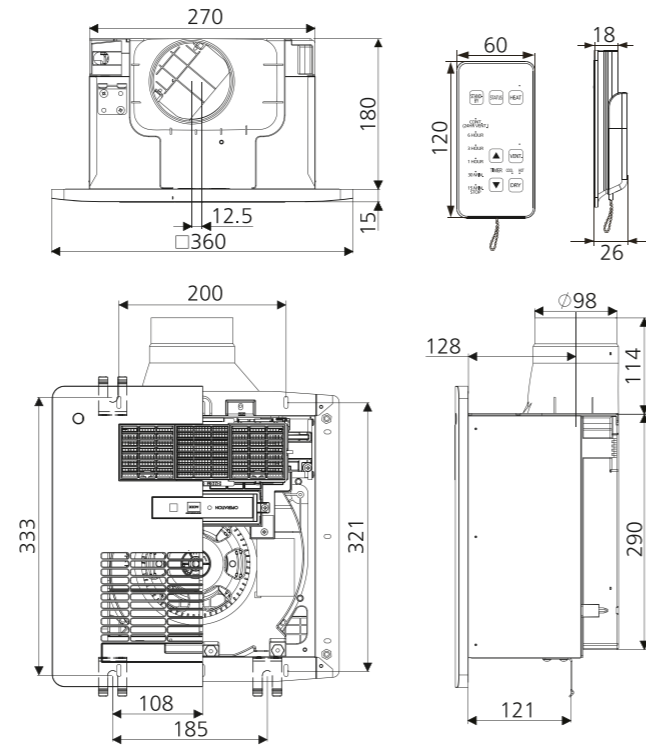

Specification

Model	Voltage		Air Volume		Consumption [W]				Noise [dB(A)]				Weight [kg]	Installation Space [mm]
	[V]	[Hz]	[CMH]	[CFM]	Heat	Vent	Dry Cool	Dry Hot	Heat	Vent	Dry Cool	Dry Hot		
30BUC	220	60	160	95	1,650	24	33	1,550	46	39	46	46	5.0	300 x 300

Test Condition

- Air volume, electric characteristic and noise are specified at the static pressure of 0 Pa
- The values of noise level is A weighted average sound pressure level, the mean values are measured by our company, within +3 to -7 dB tolerance
- The values of noise level are measured at 1 m apart from the side of fan body when ducts are connected on outlet side
- The values of air volume are the mid-points of results measured by our company, within ±10% tolerance

Wiring Diagram

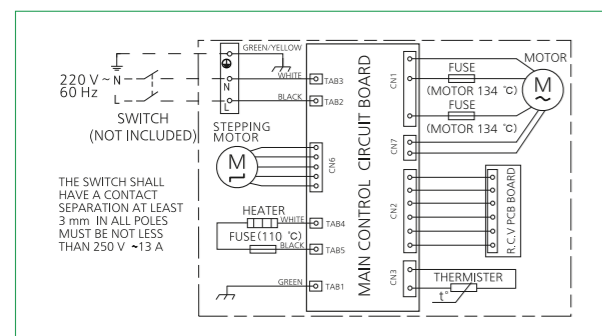

Range Hood



Powerful



Easy to Clean

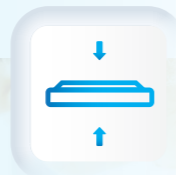

Slim Design



Scan for more information



Feature of Range Hood

Sirocco Fan

The adopted sirocco fans can outperform the turbo fans while keeping the noise level low.

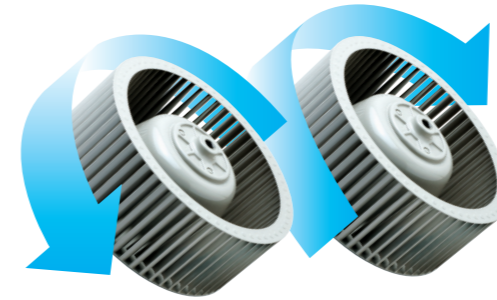

A typical range hood installation involves a long duct with at least one bending like the diagram below. Under a condition of adopting 1.5m long duct with a grille that results a static pressure of 80Pa, KDK range hood's air volume can reach 580 m³/h at Point C while some other brands can only reach 530 m³/h at Point D as illustrated in the graph on the left.

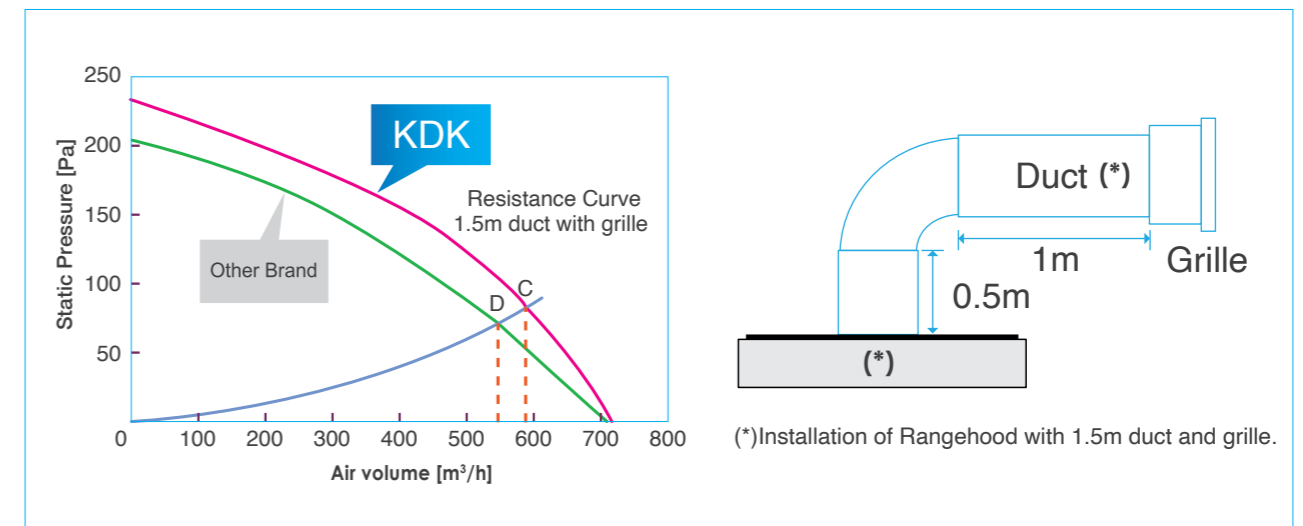

Example

Comparison of Suction Power	Air Volume [m ³ /h]								
	without duct	5m duct		10m duct		15m duct		*1.5m duct grille	
KDK	720	650	89%	610	84%	560	77%	580 (C)	79%
Other Brand	720	610	85%	540	75%	480	67%	530 (D)	74%



Ceiling Mount Series

Usage: **Kitchen**

90HQUA

2-speed Selection

Easy Maintenance

Slim Design



Dark Gray



Silver

- 2 motors with 2 sirocco fans adopted
- Individual control of motors with 2-speed selection
- Rocker switch
- Easy detachable for cleaning
- Slim designed main body with only 115mm thickness
- Colour option: silver / dark gray
- Motor insulation Class E

Dimension

Unit : mm

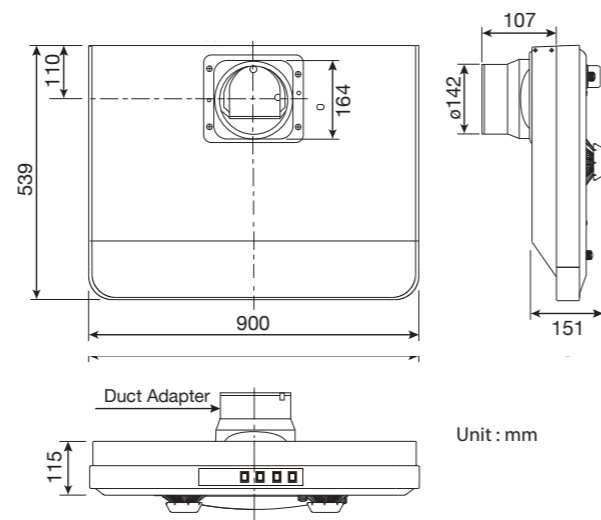

Unit : mm



Rocker Switch

Specification

Model	Voltage			Air Volume		Consumption [W]	RPM	Noise [dB(A)]	Weight [kg]	Duct Size [mm]
	[V]	[Hz]		[CMH]	[CFM]					
90HQUA	220	50	Hi	785	462	152	993	52	18.0	Ø150
			Lo	484	285	75	570	38		
		60	Hi	779	459	127	905	53		
			Lo	464	273	69	594	41		
	240	50	Hi	775	456	136	911	52.7		
			Lo	523	308	80	653	43		

Test Condition

- Air volume, electric characteristic and noise are specified at the static pressure of 0 Pa
- The values of noise level is A weighted average sound pressure level, the mean values are measured by our company, within +3 to -7 dB tolerance
- The values of noise level are measured at 1 m apart from the side of fan body when ducts are connected on outlet side
- The values of air volume are the mid-points of results measured by our company, within ±10% tolerance

Wiring Diagram

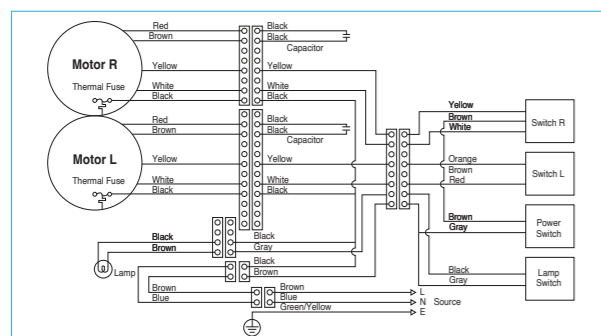

Hand Dryer



Quick Drying



Anti-bacterial



Safe



Scan for more information



Feature of Hand Dryer



Safe Operation

- Eco Dry will stop after 60 seconds of continuous operation
- "Check" indicator will light up when the unit detects overheated

Quick Response Sensor

Automatic sensor operation, no physical contact is required to activate the unit

Heater ON/OFF Switch

Heater can be switched off for energy saving in hot season

Quick Drying with 3-way Airflow



Wide Nozzle

Blow off water droplets on the whole palm with wide airflow

Spot Nozzle

Dry fine water droplets by rubbing hands with spot airflow

2 kinds of nozzle, wide nozzle and spot nozzle, are equipped at front and rear of drying chamber respectively for efficient drying. The structure realizes quick drying in only 4-9 seconds



Super Alleru-buster Filter

The filter is equipped to ensure the air blow to your hand is clean

Anti-bacteria Material as it is installed

The product body is adopted with anti-bacteria material to prevent the growth of bacteria and germs in the warm and humid environment of wash-room

(T09AC only)

Drain Pan

Drain pan can reduce water dripping on the floor to avoid slippery



What is Super alleru-buster?

Super alleru-buster can inhibit up to several types of allergen

Phenolic Polymer • Polyphenol

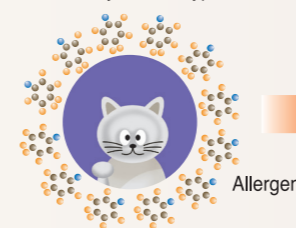

Allergen

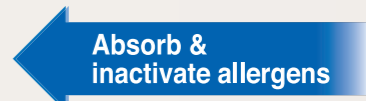
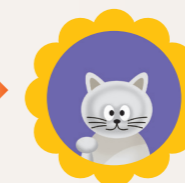

Full Tank Indicator

Remind you for cleaning up

Testing Organization: The Osaka Municipal Technical Research Institute.

Testing Method: To measure the level of reduction in cat's dandruff by Enzyme-linked Immuno Sorbent Assay.

Standard Series

Usage: Toilet

T09AC / T09BC

Anti-bacterial Body

Auto Sensor

IPX1 Protection



Dimension Unit : mm

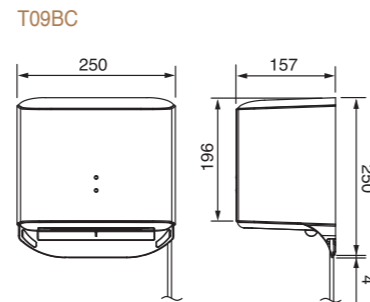
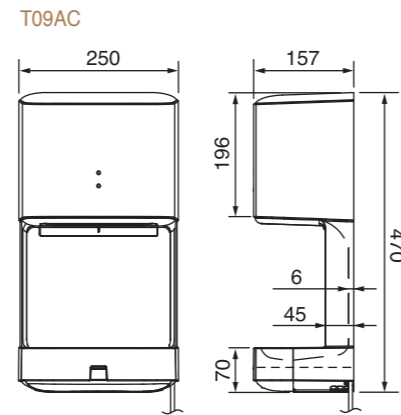

- Powerful air velocity
- Automatic operation by infra-red motion sensor
- Super alleru-buster filter equipped
- Anti-bacteria material used on product body
- ON/OFF switch for heater
- Safety check indicator
- Auto stop after 60 seconds of continuous operation
- Motor insulation Class E
- IP protection: IPX1
- T09AC only: Drain pan and water tank equipped with full tank indicator

Specification

Model	Voltage		Consumption [W]		Air Velocity [m/s]	Noise [dB(A)]	Weight [kg]
	[V]	[Hz]	Heater ON	Heater OFF			
T09AC	220	50/60	1,020	650	90-110	62	4.0
	230		1,070	700			
T09BC	220		1,020	650			
	230		1,070	700			

Wiring Diagram

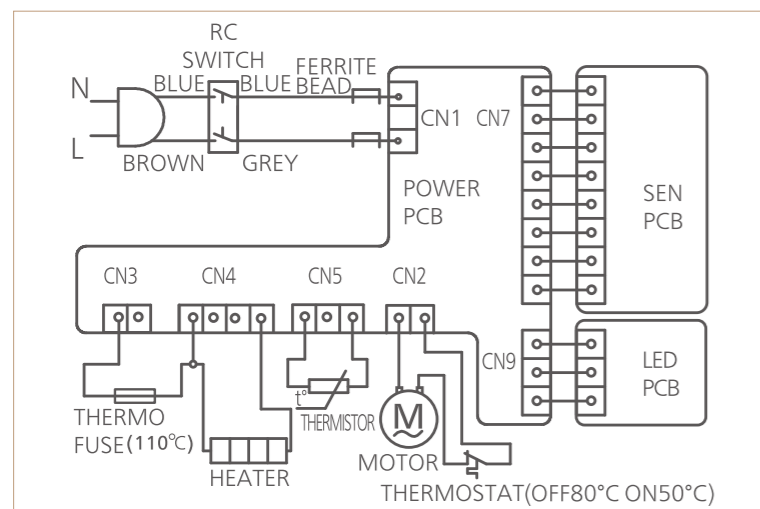

Air Curtain



Effective



Durable



Easy Maintenance



Scan for more information



Feature of Cross Flow Type Air Curtain

Efficient Barrier Effect

- The Cross Flow Fan enables wide and uniform airflow distribution while keeping up the required air volume at a low noise level.
- Unique Auxiliary Air Inlet allows more air intake at lower front that enhances airflow output.

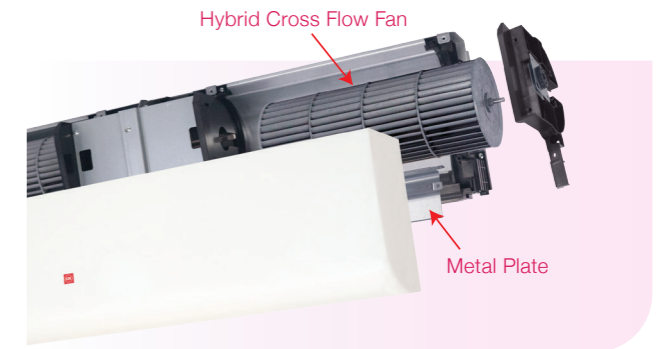

Highly Durable

- Resin with glass fiber material is used in the Hybrid Cross Flow Fan.
- Incorporated with the metal bush, the durability is prolonged significantly.

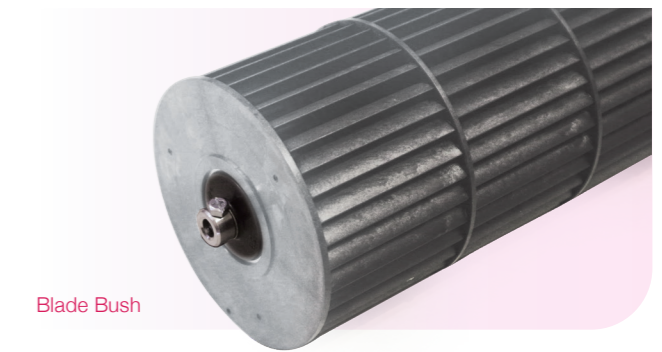

Easy Maintenance

- The Cross Flow Fan can generate air current between the fan and front cover. It forms the movement of dust that reduces dust accumulation on the fan blade.
- Simple structure allows convenient cleaning of the fan – just detach the front cover and metal plate to clean product interior.

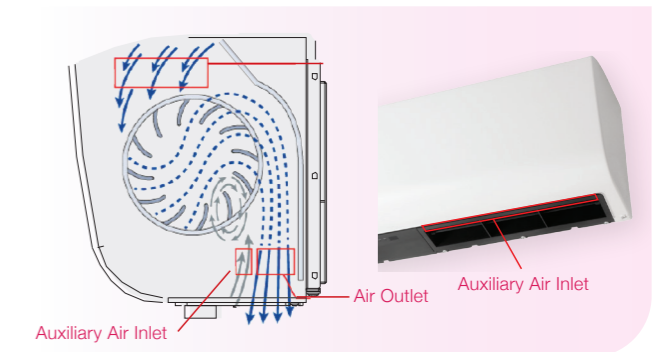

Contemporary Design

Its modern and sleek outlook with the air inlet on top well fits to the contemporary interior, delivering a clean and neat image.

Convenient Control

- For remote controlled series, Stand-by and Hi/Lo speed can be simply switched by handheld remote control.
- For sensor series, it operates when the door is sensed open. It then automatically stops after 10 seconds once the door is sensed closed.

Cross Flow Type - Remote Control Series

Usage: Shopping Mall Retail Store

3009GA / 3012GA / 3015GA
4009GA / 4012GA / 4015GA

Wide and Uniform Airflow

Resin with Glass Fibre Fan Blade

2-speed Selection



Dimension
Unit : mm

Model	3009GA	3012GA	3015GA
	4009GA	4012GA	4015GA
A	900	1,200	1,500
B	50	200	350

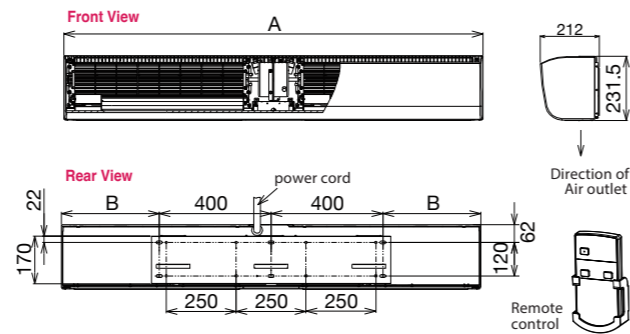

Wiring Diagram

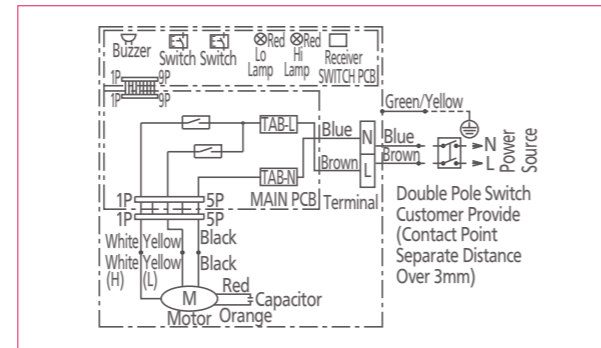

- Cross flow fan adopted for side and uniform airflow
- Thick air stream to provide high airflow momentum
- Fan blade made of resin with glass fibre and metal bush
- Permanently-lubricated ball bearing equipped
- Air deflection plate for airflow direction adjustment
- Soft touch switch panel with 2-speed selection
- Motor insulation Class B (4015GA: F)

Specification

Model	Voltage			Air Volume		Consumption [W]	Current [A]	Outlet Velocity [m/s]	Noise [dB(A)]	Weight [kg]
	[V]	[Hz]		[CMH]	[CFM]					
3009GA	220	50	Hi	1,100	647	76	0.35	10.5	48.5	12.5
			Lo	920	541	70	0.32	8.5	45.0	
		60	Hi	1,100	647	92	0.42	10.5	49.5	
	240	50	Lo	900	530	78	0.36	8.5	45.0	
			Hi	1,150	677	86	0.37	10.5	50.5	
		60	Lo	960	565	80	0.35	9.0	47.5	
4009GA	220	50	Hi	1,340	789	110	0.50	12.0	54.5	13.5
			Lo	1,190	700	94	0.43	10.0	51.0	
		60	Hi	1,340	789	141	0.64	12.0	55.5	
	240	50	Lo	1,100	647	111	0.51	10.0	51.0	
			Hi	1,360	800	122	0.51	12.5	56.5	
		60	Lo	1,200	706	100	0.43	11.0	53.5	
3012GA	220	50	Hi	1,400	824	94	0.43	9.5	48.5	15.0
			Lo	1,270	747	85	0.40	8.0	45.0	
		60	Hi	1,400	824	109	0.51	9.5	48.5	
	240	50	Lo	1,250	736	94	0.46	8.0	45.0	
			Hi	1,500	883	107	0.46	10.0	50.5	
		60	Lo	1,320	777	95	0.43	9.0	47.0	
4012GA	220	50	Hi	1,700	1,001	126	0.59	12.0	52.5	16.0
			Lo	1,530	901	105	0.49	10.0	49.0	
		60	Hi	1,700	1,001	153	0.70	12.0	52.5	
	240	50	Lo	1,450	853	118	0.55	10.0	49.0	
			Hi	1,800	1,059	139	0.60	12.5	54.5	
		60	Lo	1,580	930	110	0.49	11.0	51.0	
3015GA	220	50	Hi	2,000	1,177	131	0.59	10.5	51.5	18.5
			Lo	1,800	1,059	110	0.50	9.5	48.0	
		60	Hi	2,000	1,177	150	0.68	10.5	51.5	
	240	50	Lo	1,750	1,030	118	0.54	9.5	48.0	
			Hi	2,100	1,236	145	0.60	11.0	53.5	
		60	Lo	1,850	1,089	115	0.50	10.0	50.5	
4015GA	220	50	Hi	2,450	1,442	177	0.81	13.0	56.0	18.5
			Lo	2,000	1,177	147	0.68	10.0	52.0	
		60	Hi	2,300	1,354	220	1.01	13.0	56.0	
	240	50	Lo	1,780	1,048	160	0.74	9.5	52.0	
			Hi	2,500	1,471	200	0.86	13.5	58.0	
		60	Lo	2,050	1,207	160	0.68	11.0	54.5	

Test Condition

Note : The parameters shown above are measured at ambient temperature of 20°C
- The values of noise level are measured at 1.5 m apart from the product at angle of 45° below the air outlet at which is the maximum value
- The velocity is measured in test laboratory. It may vary depends on different environment in actual usage

Cross Flow Type - Sensor Series

Usage: Shopping Mall Retail Store

3009DA / 3012DA / 3015DA
4009DA / 4012DA / 4015DA

Wide and Uniform Airflow

Resin with Glass Fibre Fan Blade

2-speed Selection



Dimension
Unit : mm

Model	3009DA	3012DA	3015DA
	4009DA	4012DA	4015DA
A	900	1,200	1,500
B	50	200	350

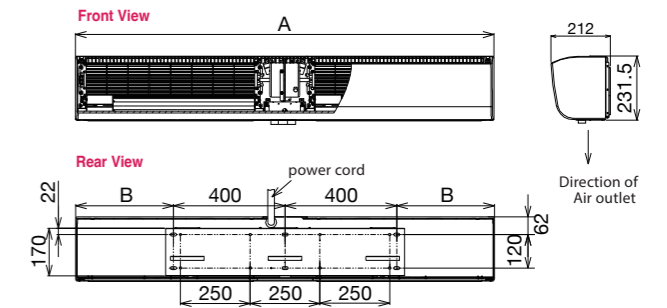

Wiring Diagram

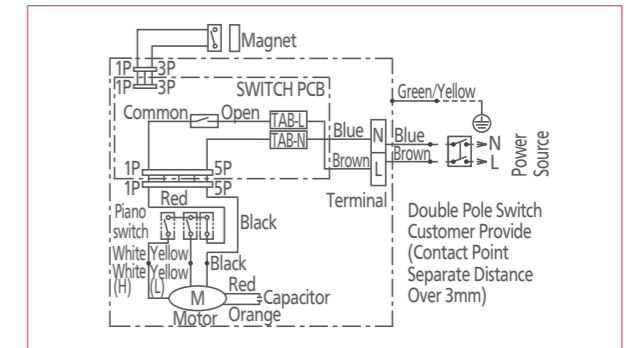

- Cross flow fan adopted for side and uniform airflow
- Thick air stream to provide high airflow momentum
- Fan blade made of resin with glass fibre and metal bush
- Permanently-lubricated ball bearing equipped
- Air deflection plate for airflow direction adjustment
- Soft touch switch panel with 2-speed selection
- Motor insulation Class B (4015DA: F)

Specification

Model	Voltage			Air Volume		Consumption [W]	Current [A]	Outlet Velocity [m/s]	Noise [dB(A)]	Weight [kg]
	[V]	[Hz]		[CMH]	[CFM]					
3009DA	220	50	Hi	1,100	647	76	0.35	10.5	48.5	12.5
			Lo	920	541	70	0.32	8.5	45.0	
		60	Hi	1,100	647	92	0.42	10.5	49.5	
	240	50	Lo	900	530	78	0.36	8.5	45.0	
			Hi	1,150	677	86	0.37	10.5	50.5	
		60	Lo	960	565	80	0.35	9.0	47.5	
4009DA	220	50	Hi	1,340	789	110	0.50	12.0	54.5	13.5
			Lo	1,190	700	94	0.43	10.0	51.0	
		60	Hi	1,340	789	141	0.64	12.0	55.5	
	240	50	Lo	1,100	647	111	0.51	10.0	51.0	
			Hi	1,360	800	122	0.51	12.5	56.5	
		60	Lo	1,200	706	100	0.43	11.0	53.5	
3012DA	220	50	Hi	1,400	824	94	0.43	9.5	48.5	15.0
			Lo	1,270	747	85	0.40	8.0	45.0	
		60	Hi	1,400	824	109	0.51	9.5	48.5	
	240	50	Lo	1,250	736	94	0.46	8.0	45.0	
			Hi	1,500	883	107	0.46	10.0	50.5	
		60	Lo	1,320	777	95	0.43	9.0	47.0	
4012DA	220	50	Hi	1,700	1,001	126	0.59	12.0	52.5	16.0
			Lo	1,530	901	105	0.49	10.0	49.0	
		60	Hi	1,700	1,001	153	0.70	12.0	52.5	
	240	50	Lo	1,450	853	118	0.55	10.0	49.0	
			Hi	1,800	1,059	139	0.60	12.5	54.5	
		60	Lo	1,580	930	110	0.49	11.0	51.0	
3015DA	220	50	Hi	2,000	1,177	131	0.59	10.5	51.5	18.5
			Lo	1,800	1,059	110	0.50	9.5	48.0	
		60	Hi	2,000	1,177	150	0.68	10.5	51.5	
	240	50	Lo	1,750	1,030	118	0.54	9.5	48.0	
			Hi	2,100	1,236	145	0.60	11.0	53.5	
		60	Lo	1,850	1,089	115	0.50	10.0	50.5	
4015DA	220	50	Hi	2,450	1,442	177	0.81	13.0	56.0	18.5
			Lo	2,000	1,177	147	0.68	10.0	52.0	
		60	Hi	2,300	1,354	220	1.01	13.0	56.0	
	240	50	Lo	1,780	1,048	160	0.74	9.5	52.0	
			Hi	2,500	1,471	200	0.86	13.5	58.0	
		60	Lo	2,050	1,207	160	0.68	11.0	54.5	

Test Condition

Note : The parameters shown above are measured at ambient temperature of 20°C
- The values of noise level are measured at 1.5 m apart from the product at angle of 45° below the air outlet at which is the maximum value
- The velocity is measured in test laboratory. It may vary depends on different environment in actual usage

Cross Flow Type - Standard Series

Usage: Shopping Mall Retail Store

3009UA / 3012UA / 3015UA
4009UA / 4012UA / 4015UA

- Wide and Uniform Airflow
- Resin with Glass Fibre Fan Blade
- 2-speed Selection



- Cross flow fan adopted for side and uniform airflow
- Thick air stream to provide high airflow momentum
- Fan blade made of resin with glass fibre and metal bush
- Permanently-lubricated ball bearing equipped
- Air deflection plate for airflow direction adjustment
- Soft touch switch panel with 2-speed selection
- Motor insulation Class B (4015UA: F)

Dimension

Unit : mm

Model	3009UA	3012UA	3015UA
	4009UA	4012UA	4015UA
A	900	1,200	1,500
B	50	200	350

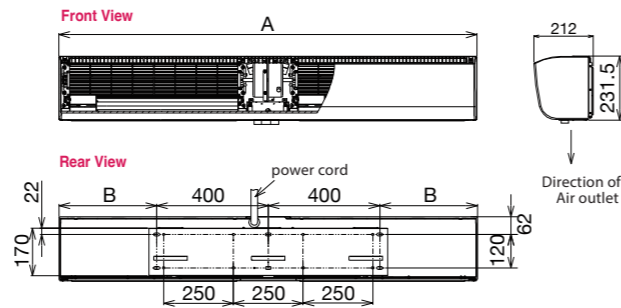

Wiring Diagram

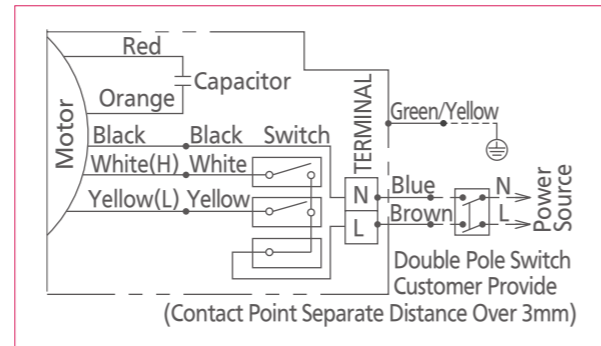

Feature of Sirocco Type Air Curtain

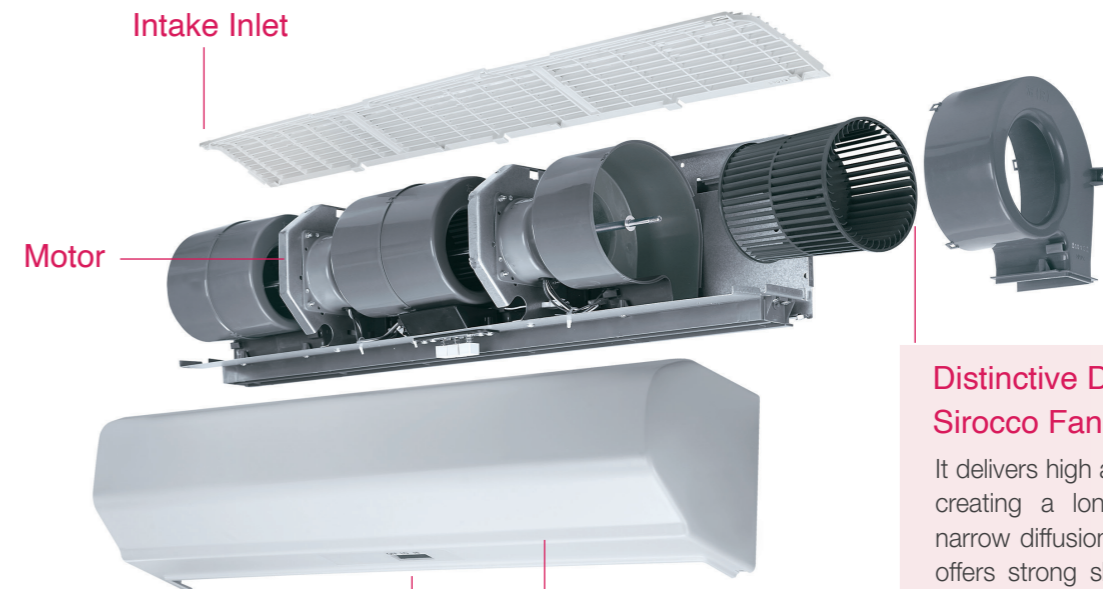

Distinctive Design of Sirocco Fan

It delivers high air velocity, yet creating a long reach and narrow diffusion of airflow. It offers strong shut out ability while allowing people passing through comfortably.

ABS Resin Casing

ABS is a material highly resistant to rust and with high bending flexibility, that enables a sleek, simple design fitting to modern interiors.

2-speed Function



Specification

Model	Voltage		Air Volume		Consumption [W]	Current [A]	Outlet Velocity [m/s]	Noise [dB(A)]	Weight [kg]
	[V]	[Hz]	[CMH]	[CFM]					
3009UA	220	50	Hi 1,100	647	76	0.35	10.5	48.5	12.5
		60	Lo 920	541	70	0.32	8.5	45.0	
	240	50	Hi 1,100	647	92	0.42	10.5	49.5	
		60	Lo 900	530	78	0.36	8.5	45.0	
4009UA	220	50	Hi 1,150	677	86	0.37	10.5	50.5	13.5
		60	Lo 960	565	80	0.35	9.0	47.5	
	240	50	Hi 1,340	789	110	0.50	12.0	54.5	
		60	Lo 1,190	700	94	0.43	10.0	51.0	
3012UA	220	50	Hi 1,340	789	141	0.64	12.0	55.5	15.0
		60	Lo 1,100	647	111	0.51	10.0	51.0	
	240	50	Hi 1,360	800	122	0.51	12.5	56.5	
		60	Lo 1,200	706	100	0.43	11.0	53.5	
4012UA	220	50	Hi 1,400	824	94	0.43	9.5	48.5	16.0
		60	Lo 1,270	747	85	0.40	8.0	45.0	
	240	50	Hi 1,400	824	109	0.51	9.5	48.5	
		60	Lo 1,250	736	94	0.46	8.0	45.0	
3015UA	220	50	Hi 1,500	883	107	0.46	10.0	50.5	18.5
		60	Lo 1,320	777	95	0.43	9.0	47.0	
	240	50	Hi 1,700	1,001	126	0.59	12.0	52.5	
		60	Lo 1,530	901	105	0.49	10.0	49.0	
4015UA	220	50	Hi 1,700	1,001	153	0.70	12.0	52.5	18.5
		60	Lo 1,450	853	118	0.55	10.0	49.0	
	240	50	Hi 1,800	1,059	139	0.60	12.5	54.5	
		60	Lo 1,580	930	110	0.49	11.0	51.0	
3015UA	220	50	Hi 2,000	1,177	131	0.59	10.5	51.5	18.5
		60	Lo 1,800	1,059	110	0.50	9.5	48.0	
	240	50	Hi 2,000	1,177	150	0.68	10.5	51.5	
		60	Lo 1,750	1,030	118	0.54	9.5	48.0	
4015UA	220	50	Hi 2,100	1,236	145	0.60	11.0	53.5	18.5
		60	Lo 1,850	1,089	115	0.50	10.0	50.5	
	240	50	Hi 2,450	1,442	177	0.81	13.0	56.0	
		60	Lo 2,000	1,177	147	0.68	10.0	52.0	
4015UA	220	50	Hi 2,300	1,354	220	1.01	13.0	56.0	18.5
		60	Lo 1,780	1,048	160	0.74	9.5	52.0	
	240	50	Hi 2,500	1,471	200	0.86	13.5	58.0	
		60	Lo 2,050	1,207	160	0.68	11.0	54.5	

Test Condition
 Note : The parameters shown above are measured at ambient temperature of 20°C
 - The values of noise level are measured at 1.5 m apart from the product at angle of 45° below the air outlet at which is the maximum value
 - The velocity is measured in test laboratory. It may vary depends on different environment in actual usage

Length of unit	900mm (3 feet)	1200mm (4 feet)	900mm (3 feet)	1200mm (4 feet)	900mm (3 feet)	1200mm (4 feet)	900mm (3 feet)	1200mm (4 feet)
	08ESK	08ELK	10ESK	10ELK	12ESK	12ELK	14ESK	14ELK
Air velocity chart (m/s)								
Maximum value at HI speed 50Hz	3.5 - 4.5		4.5 - 5.5		6.0 - 7.0		7.5 - 8.5	
Efficient distance	2.5m (8 feet)		3.0m (10 feet)		3.5m (12 feet)		4.0m (14 feet)	



Sirocco Type - 900 Series

Usage: Shopping Mall Retail Store

08ESK / 10ESK
12ESK / 14ESK

Push Button Switch

ABS Resin Casing

2-speed Selection

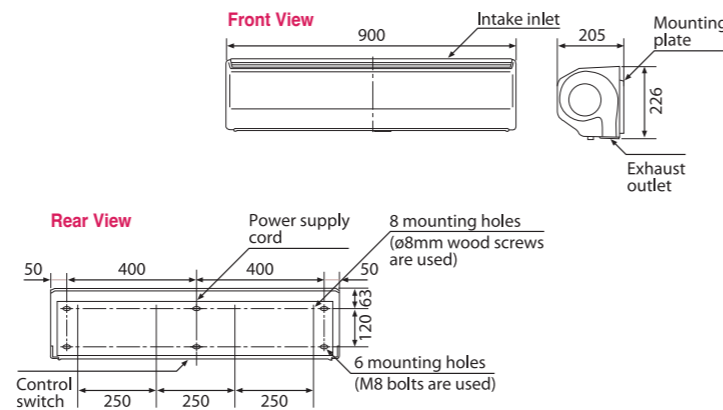

Wiring Diagram

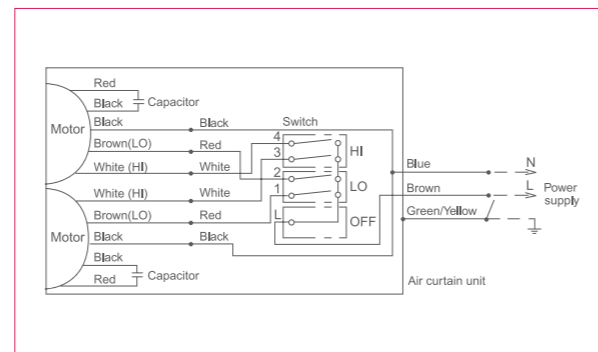

- Sirocco fan adopted for long reach and narrow diffusion of airflow
- ABS resin casing to provide better weather resistance
- Permanently-lubricated ball bearing equipped
- Air deflection plate for airflow direction adjustment
- Push button switch
- 2-speed selection
- Motor insulation Class E

Specification

Model	Voltage			Air Volume		Consumption [W]	Current [A]	Outlet Velocity [m/s]	Noise [dB(A)]	Weight [kg]
	[V]	[Hz]		[CMH]	[CFM]					
08ESK	220	50	Hi	650	383	46	0.23	11.5	42	12.0
			Lo	580	341	42	0.21	10.3	39	
		60	Hi	690	406	57	0.28	12.1	43	
			Lo	560	330	49	0.25	9.9	38	
	240	50	Hi	680	400	51	0.24	11.9	43	
			Lo	620	365	47	0.23	10.9	41	
10ESK	220	50	Hi	750	441	72	0.40	13.0	46	12.0
			Lo	630	371	62	0.29	11.1	42	
		60	Hi	860	506	88	0.42	14.9	50	
			Lo	600	353	72	0.33	10.9	40	
	240	50	Hi	750	441	84	0.46	13.2	46	
			Lo	630	371	66	0.30	11.7	43	
12ESK	220	50	Hi	1,050	618	176	0.82	16.9	55	13.0
			Lo	960	565	155	0.69	15.8	50	
		60	Hi	990	583	202	0.94	16.1	54	
			Lo	940	553	170	0.75	15.3	49	
	240	50	Hi	1,120	659	200	0.86	17.9	57	
			Lo	1,040	612	169	0.75	16.8	54	
14ESK	220	50	Hi	1,340	789	257	1.14	21.9	62	13.0
			Lo	1,168	687	218	0.99	19.1	59	
		60	Hi	1,303	767	312	1.43	21.3	61	
			Lo	1,083	637	255	1.16	17.7	57	
	240	50	Hi	1,395	821	281	1.18	22.8	63	
			Lo	1,272	749	238	1.00	20.8	60	

Test Condition

Note : The parameters shown above are measured at ambient temperature of 20°C

- The values of noise level are measured at 1.5 m apart from the product at angle of 45° below the air outlet at which is the maximum value

- The velocity is measured in test laboratory. It may vary depends on different environment in actual usage

Sirocco Type - 1200 Series

Usage: Shopping Mall Retail Store

08ELK / 10ELK
12ELK / 14ELK

Push Button Switch

ABS Resin Casing

2-speed Selection

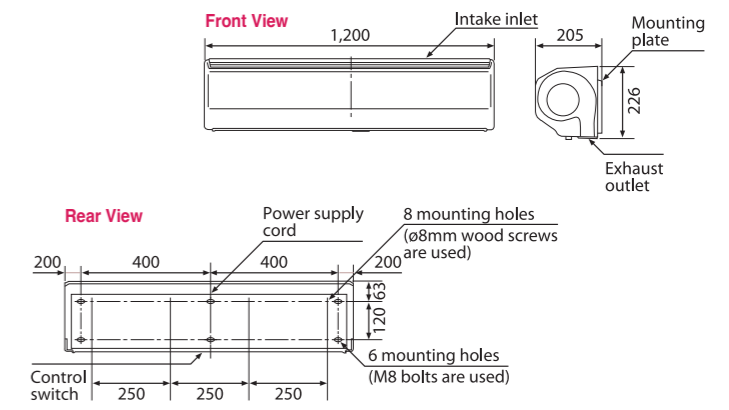

Wiring Diagram

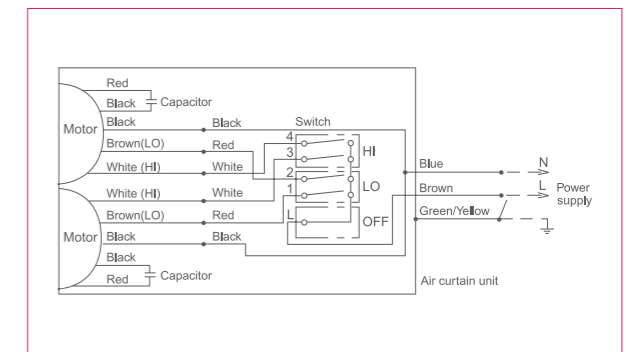

- Sirocco fan adopted for long reach and narrow diffusion of airflow
- ABS resin casing to provide better weather resistance
- Permanently-lubricated ball bearing equipped
- Air deflection plate for airflow direction adjustment
- Push button switch
- 2-speed selection
- Motor insulation Class E

Specification

Model	Voltage			Air Volume		Consumption [W]	Current [A]	Outlet Velocity [m/s]	Noise [dB(A)]	Weight [kg]
	[V]	[Hz]		[CMH]	[CFM]					
08ELK	220	50	Hi	880	518	57	0.28	11.6	43	14.0
			Lo	800	471	53	0.27	10.6	41	
		60	Hi	940	553	74	0.36	12.4	45	
			Lo	790	465	62	0.32	10.5	40	
	240	50	Hi	920	541	65	0.29	12.1	44	
			Lo	850	500	59	0.28	11.2	42	
10ELK	220	50	Hi	1,000	589	96	0.54	13.1	46	14.0
			Lo	830	489	74	0.35	11.0	42	
		60	Hi	1,150	677	116	0.56	15.1	50	
			Lo	790	465	85	0.41	10.5	41	
	240	50	Hi	1,010	594	116	0.66	13.2	47	
			Lo	880	518	86	0.38	11.6	43	
12ELK	220	50	Hi	1,420	836	224	1.04	17.0	56	15.0
			Lo	1,320	777	200	0.90	15.8	51	
		60	Hi	1,340	789	258	1.21	16.2	55	
			Lo	1,290	759	220	1.04	15.4	50	
	240	50	Hi	1,510	889	252	1.10	17.9	58	
			Lo	1,410	830	218	0.98	16.7	56	
14ELK	220	50	Hi	1,867	1,099	333	1.52	22.5	63	15.0
			Lo	1,668	982	290	1.32	20.1	61	
		60	Hi	1,826	1,075	423	1.93	22.0	63	
			Lo	1,552	913	339	1.55	18.7	59	
	240	50	Hi	1,942	1,143	364	1.53	23.4	64	
			Lo	1,818	1,070	320	1.33	21.9	62	

Test Condition

Note : The parameters shown above are measured at ambient temperature of 20°C

- The values of noise level are measured at 1.5 m apart from the product at angle of 45° below the air outlet at which is the maximum value

- The velocity is measured in test laboratory. It may vary depends on different environment in actual usage

Ceiling Fan / Electric Fan



High Breeze



Quiet



Safe



Scan for more information
Ceiling Fan Electric Fan



Safety Feature of Ceiling Fan

In pursuit of high quality of life, ceiling fans are expected with multiple functions and more value-added features. Safety and reliability have become the major concerns when selecting a ceiling fan.

Safety Shaft Cap

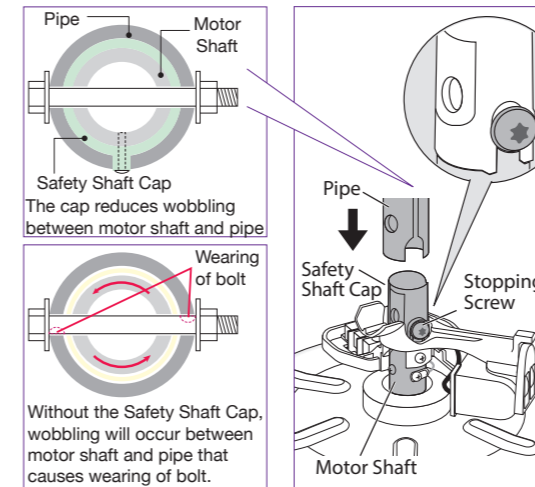

Problem

Improper movement causes friction between bolt, motor shaft and pipe that increases wear and tear and cause fracture.

Our solution

Safety Shaft Cap can reduce movement between bolt, motor shaft and pipe. This minimizes wearing of motor shaft and bolt, thus prevent falling of fan.

Safety Wire

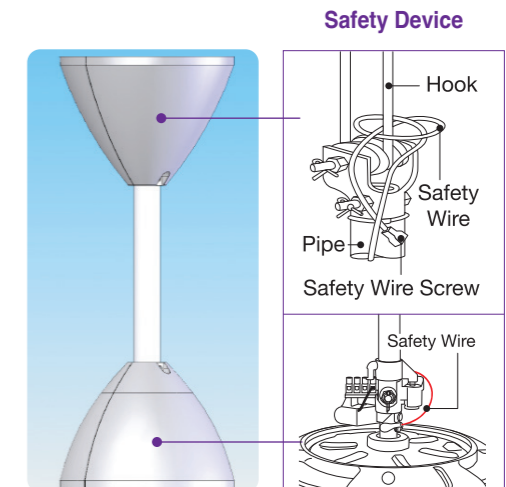

Problem

Fan motor may fall from the pipe rod accidentally due to factors such as wearing of shaft, bolt etc.

Our solution

Safety wire helps to secure fan motor with ceiling hook. This prevents falling of motor in case it detaches from the pipe rod.

Safety Blade Plate / Hanger

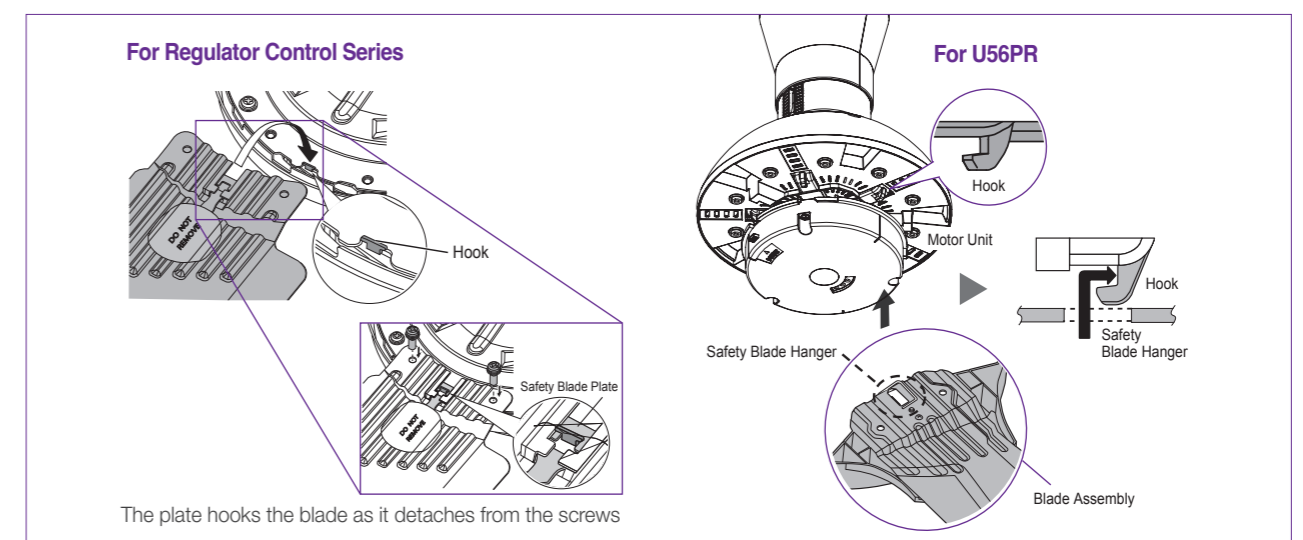

Problem

Blade may break and fall off from fan motor in case fatigue failure of material occurs.

Our solution

An exclusively designed fall prevention plate / hanger is equipped to hold blade to the motor in case of breakage. This mechanism secures against falling of blade.

Remote Control Series

Usage: Living Room Bedroom Restaurant Lobby

U56PR

- Remote Control
- Fall Prevention Measures
- Metal Blades



- 3-speed selection
- Off Timer with LED indicator (1, 3, 6 hours)
- Sleep mode
- Thermal fuse to prevent overheating
- Current fuse to secure against power surge
- Safety wire provided
- Safety shaft cap to prevent fan falling
- Permanently lubricated ball bearing equipped
- Motor insulation Class E
- Colour: White body with golden ring

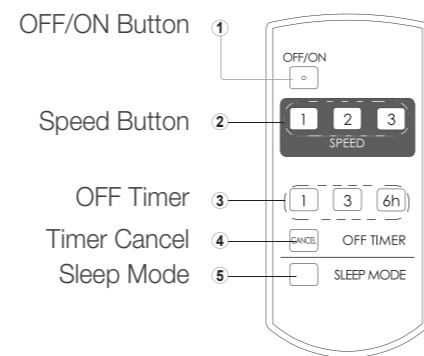
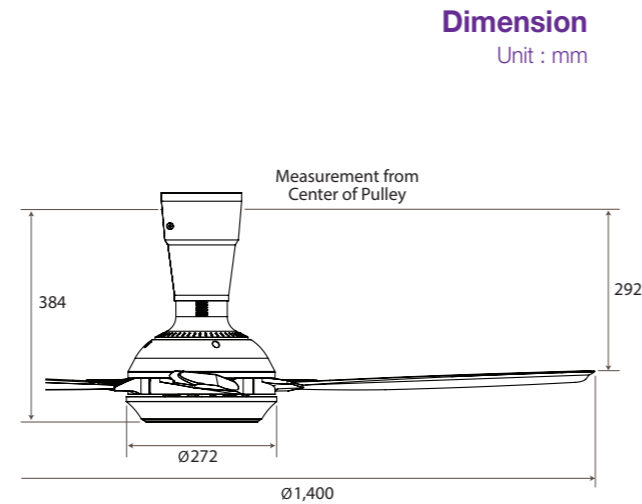

Wiring Diagram

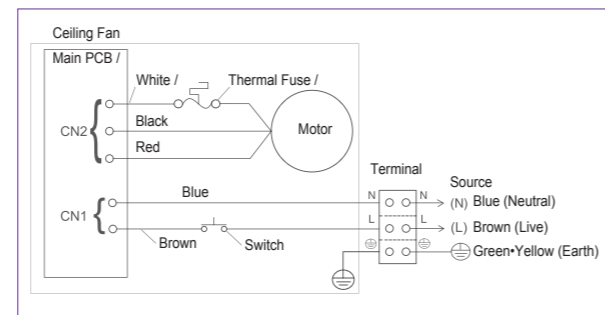

Specification

Model	Voltage [V]	Frequency [Hz]	*	Consumption [W]	RPM	Air Velocity		Air Volume		Weight [kg]
						[m/min]	[ft/min]	[m³/min]	[ft³/min]	
U56PR	220	50	Hi	62	175	137	449	181	6,392	6.7
			Lo	20	87	-	-	-	-	
		Hi	74	182	146	479	194	6,851		
	230	50	Lo	21	89	-	-	-	-	
			Hi	66	182	146	479	194	6,851	
		Lo	19	89	-	-	-	-		
240	50	Hi	73	188	153	502	204	7,204		
		Lo	20	94	-	-	-	-		

*Hi - Notch 3 / Lo - Notch 1

Regulator Control Series

Usage: Living Room Bedroom Restaurant Lobby

T48XC / T56XC

- Slim Panel Regulator
- Fall Prevention Measures
- Metal Blades



- 5-speed selection
- Thermal fuse to prevent overheating
- Safety wire provided
- Safety shaft cap to prevent fan falling
- Permanently lubricated ball bearing equipped
- Motor insulation Class E
- Colour option: Gray body with silver ring
White body with golden ring

Dimension					
Unit : mm					
Model	9 inch	12 inch	16 inch	18 inch	22 inch
Pipe Length	229	305	406	457	559
F	437	513	614	665	764

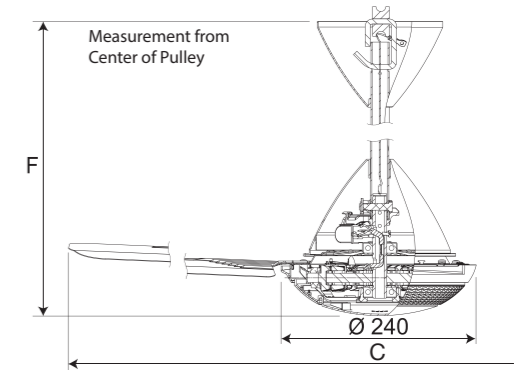

Model :	C
T48XC	Ø1,200
T48XGMN	Ø1,200
T56XC	Ø1,400
T56XGMN	Ø1,400

Wiring Diagram

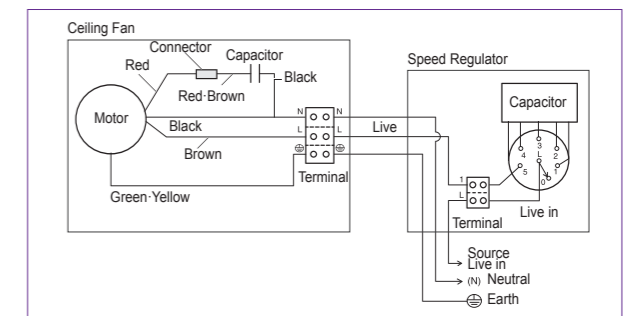

Specification

Model	Voltage [V]	Frequency [Hz]	*	Consumption [W]	RPM	Air Velocity		Air Volume		Weight [kg]
						[m/min]	[ft/min]	[m³/min]	[ft³/min]	
T48XC	220	50	Hi	45	285	160	525	155	5,474	5.3
			Lo	15	137	-	-	-	-	
		Hi	55	311	175	574	170	6,003		
	230	50	Lo	15	129	-	-	-	-	
			Hi	49	296	165	541	170	6,003	
		Lo	16	146	-	-	-	-		
T56XC	220	50	Hi	51	303	170	558	165	5,827	5.6
			Lo	18	154	-	-	-	-	
		Hi	70	268	165	541	220	7,769		
	230	50	Lo	14	103	-	-	-	-	
			Hi	76	268	170	558	225	7,946	
		Lo	17	106	-	-	-	-		
240	50	Hi	75	275	170	558	225	7,946		
		Lo	15	109	-	-	-	-		
	Hi	76	273	165	541	220	7,769			
Lo	17	115	-	-	-	-				

*Hi - Notch 5 / Lo - Notch 1

Regulator Control Series

Usage: Living Room Bedroom Restaurant Lobby

T48XG / T56XG

- Compact Regulator
- Fall Prevention Measures
- Metal Blades



- 5-speed selection
- Thermal fuse to prevent overheating
- Safety wire provided
- Safety shaft cap to prevent fan falling
- Permanently lubricated ball bearing equipped
- Glossy diamond-pattern fan ring
- Motor insulation Class E
- Colour option: White body with golden ring
Gray body with silver ring

Dimension
Unit : mm

Model	9 inch	12 inch	16 inch	18 inch	22 inch
Pipe Length	229	305	406	457	559
F	437	513	614	665	764

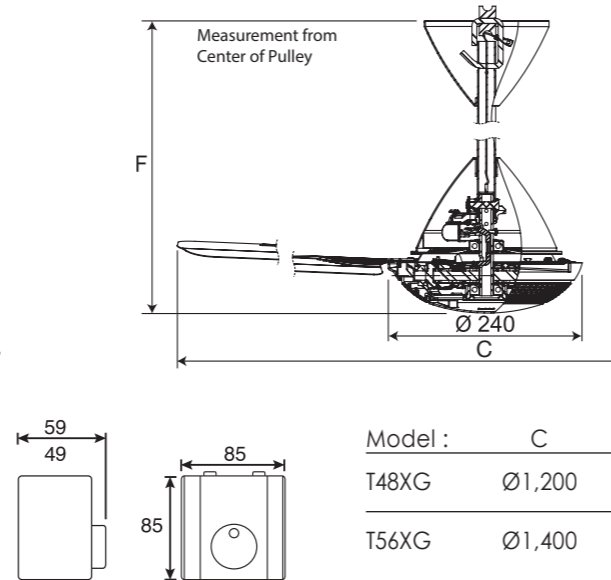

Wiring Diagram

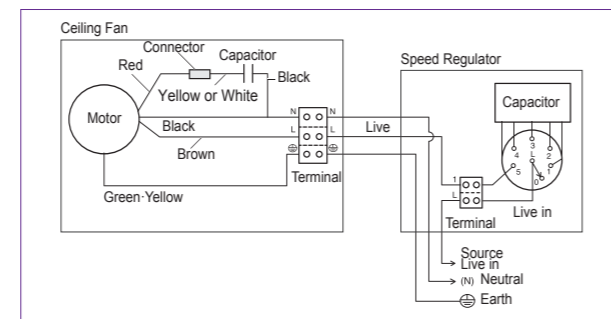

Specification

Model	Voltage [V]	Frequency [Hz]	*	Consumption [W]	RPM	Air Velocity		Air Volume		Weight [kg]
						[m/min]	[ft/min]	[m³/min]	[ft³/min]	
T48XG	220	50	Hi	45	285	160	525	155	5,474	5.3
			Lo	15	137	-	-	-	-	
		60	Hi	55	311	175	574	170	6,003	
			Lo	15	129	-	-	-	-	
	230	50	Hi	49	296	165	541	170	6,003	
			Lo	16	146	-	-	-	-	
		240	Hi	51	303	170	558	165	5,827	
			Lo	18	154	-	-	-	-	
T56XG	220	50	Hi	70	268	165	541	220	7,769	5.6
			Lo	14	103	-	-	-	-	
		60	Hi	76	268	170	558	225	7,946	
			Lo	17	106	-	-	-	-	
	230	50	Hi	75	275	170	558	225	7,946	
			Lo	15	109	-	-	-	-	
		240	Hi	76	273	165	541	220	7,769	
			Lo	17	115	-	-	-	-	

*Hi - Notch 5 / Lo - Notch 1

Regulator Control Series

Usage: Living Room Bedroom Restaurant Lobby

X48XC / X56XC

- Slim Panel Regulator
- Fall Prevention Measures
- Metal Blades



- 5-speed selection
- Thermal fuse to prevent overheating
- Safety wire provided
- Safety shaft cap to prevent fan falling
- Permanently lubricated ball bearing equipped
- Motor insulation Class E
- Colour: White body with silver ring

Dimension
Unit : mm

Model	9 inch	12 inch	16 inch	18 inch	22 inch
Pipe Length	229	305	406	457	559
F	437	513	614	665	764

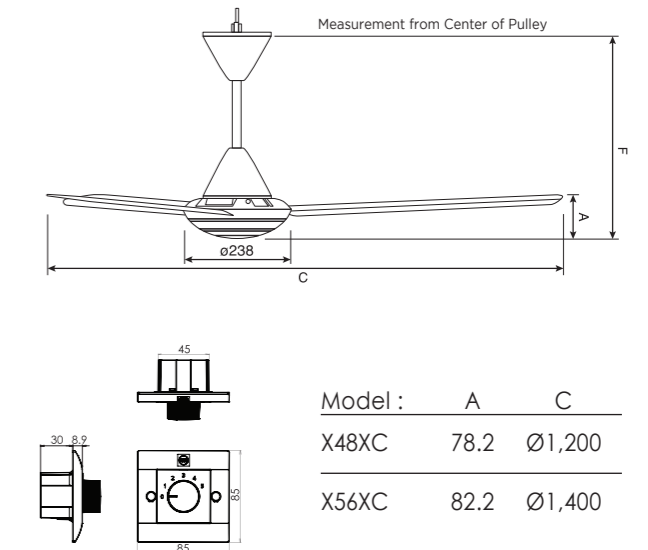

Wiring Diagram

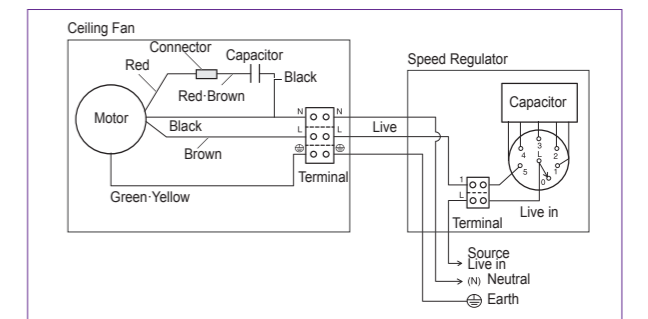

Specification

Model	Voltage [V]	Frequency [Hz]	*	Consumption [W]	RPM	Air Velocity		Air Volume		Weight [kg]
						[m/min]	[ft/min]	[m³/min]	[ft³/min]	
X48XC	220	50	Hi	45	285	160	525	155	5,474	5.3
			Lo	15	137	-	-	-	-	
		60	Hi	55	311	175	574	170	6,003	
			Lo	15	129	-	-	-	-	
	230	50	Hi	49	296	165	541	170	6,003	
			Lo	16	146	-	-	-	-	
		240	Hi	51	303	170	558	165	5,827	
			Lo	18	154	-	-	-	-	
X56XC	220	50	Hi	70	268	165	541	220	7,769	5.6
			Lo	14	103	-	-	-	-	
		60	Hi	76	268	170	558	225	7,946	
			Lo	17	106	-	-	-	-	
	230	50	Hi	75	275	170	558	225	7,946	
			Lo	15	109	-	-	-	-	
		240	Hi	76	273	165	541	220	7,769	
			Lo	17	115	-	-	-	-	

*Hi - Notch 5 / Lo - Notch 1

Regulator Control Series

Usage: Living Room Bedroom Restaurant Lobby

X48XG / X56XG

- Compact Regulator
- Fall Prevention Measures
- Metal Blades

Dimension
Unit : mm

Model	9 inch	12 inch	16 inch	18 inch	22 inch
Pipe Length	229	305	406	457	559
F	437	513	614	665	764

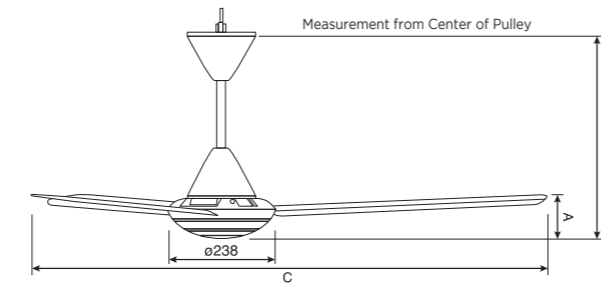

Model :	A	C
X48XG	78.2	Ø1,200
X56XG	82.2	Ø1,400

- 5-speed selection
- Thermal fuse to prevent overheating
- Safety wire provided
- Safety shaft cap to prevent fan falling
- Permanently lubricated ball bearing equipped
- Motor insulation Class E
- Colour: White body with silver ring

Wiring Diagram

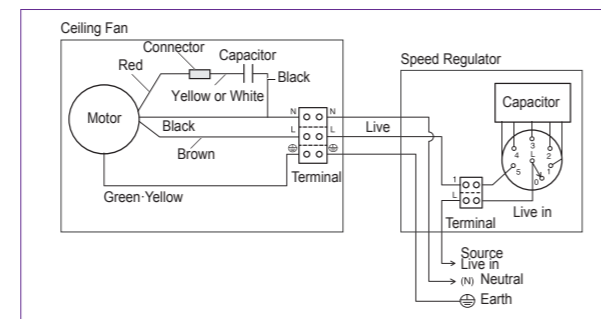

Specification

Model	Voltage [V]	Frequency [Hz]	*	Consumption [W]	RPM	Air Velocity		Air Volume		Weight [kg]
						[m/min]	[ft/min]	[m³/min]	[ft³/min]	
X48XG	220	50	Hi	45	285	160	525	155	5,474	5.3
			Lo	15	137	-	-	-	-	
		60	Hi	55	311	175	574	170	6,003	
			Lo	15	129	-	-	-	-	
	230	50	Hi	49	296	165	541	170	6,003	
			Lo	16	146	-	-	-	-	
240	50	Hi	51	303	170	558	165	5,827		
		Lo	18	154	-	-	-	-		
X56XG	220	50	Hi	70	268	165	541	220	7,769	5.6
			Lo	14	103	-	-	-	-	
		60	Hi	76	268	170	558	225	7,946	
			Lo	17	106	-	-	-	-	
	230	50	Hi	75	275	170	558	225	7,946	
			Lo	15	109	-	-	-	-	
240	50	Hi	76	273	165	541	220	7,769		
		Lo	17	115	-	-	-	-		

*Hi - Notch 5 / Lo - Notch 1

Cycle Fan

Usage: Living Room Bedroom Restaurant School

M40R

- 360° Oscillation
- Regulator
- Metal Blades

Adjustment of Circulating Angle

The oscillation angle can be adjusted to 15, 30, 50 degrees.

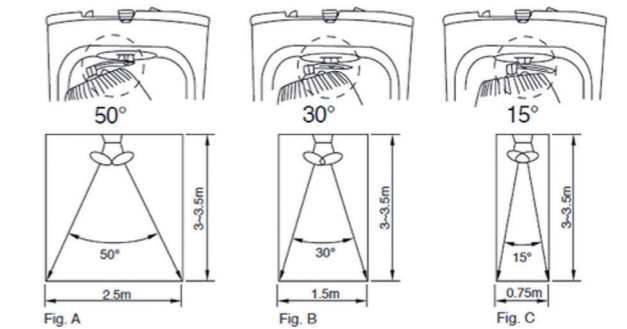

- 5-speed selection
- Oscillation over 360°
- Speed and ON/OFF controlled by regulator
- Easy adjustment for circulating angle (15°, 30°, 50°)
- Thermal fuse to prevent overheating
- Safety wire provided
- Permanently lubricated ball bearing equipped
- Painted metal blades
- Colour option: Blue
- Gray

Wiring Diagram

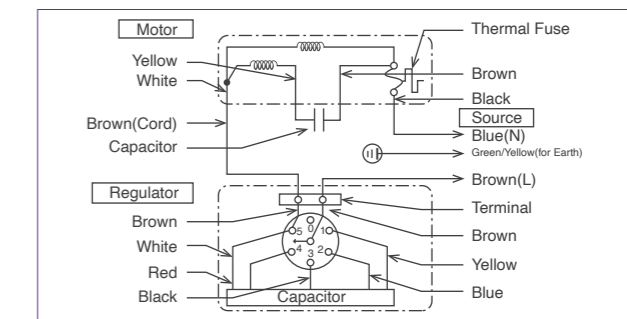

Specification

Model	Voltage [V]	Frequency [Hz]	*	Consumption [W]	RPM	Air Velocity		Air Volume		Weight [kg]
						[m/min]	[ft/min]	[m³/min]	[ft³/min]	
M40R	220	50	Hi	46.8 - 57.2	1,080 - 1,320	256	840	79	2,790	4.3
			Lo	22.5 - 27.5	690 - 850	-	-	-	-	
		60	Hi	57.7 - 70.5	1,160 - 1,410	277	909	86	3,037	
			Lo	26.6 - 32.5	710 - 860	-	-	-	-	

*Hi - Notch 5 / Lo - Notch 1

Wall Fan - Cord-Operated Series

Usage: Living Room Bedroom Restaurant School

M30C / M40C

Pull Switch

Easy Angle Adjustment

3-speed Selection

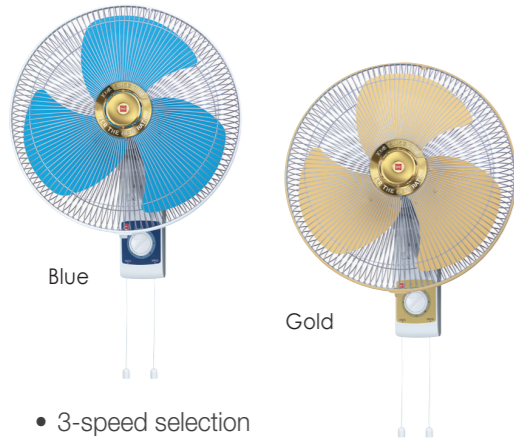

- 3-speed selection
- Speed and ON/OFF controlled by pull switch
- Speed and Oscillation change by pull cord
- Easy adjustment for tilt angle and oscillation angle
- Thermal fuse to prevent overheating
- Safety shaft cap to prevent fan falling
- Permanently lubricated ball bearing equipped
- Colour option: Blue (M30C and M40C)
Gold (M40C only)

Adjustment of Tilt Angle and Oscillation Angle

“One-touch” adjustment of tilt

The airflow can be adjusted upward or downward by simply moving the guard up or down as shown in the figure. Adjust the angle of the fan only after first confirming that it has stopped rotating.

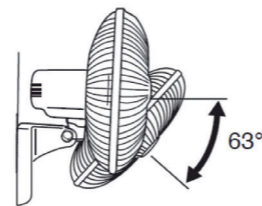

Double oscillation

To change the direction of the air flow, simply push the fan guard to the desired position.

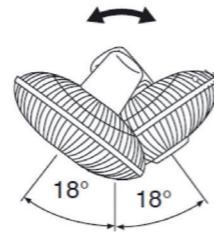

Installation

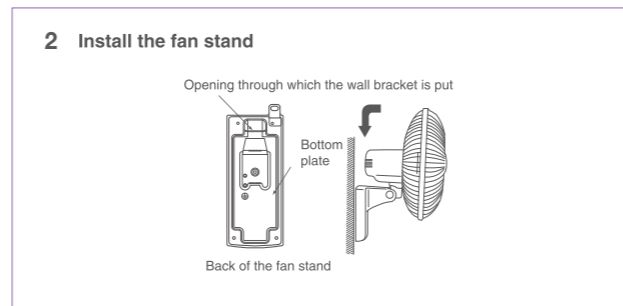
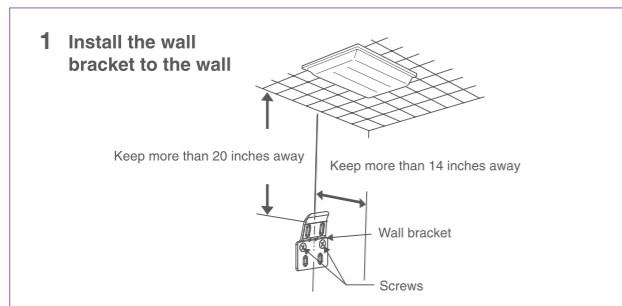

Specification

Model	Voltage [V]	Frequency [Hz]	*	Consumption [W]	RPM	Air Velocity		Air Volume		Weight [kg]
						[m/min]	[ft/min]	[m³/min]	[ft³/min]	
M30C	220	50	Hi	34.0 - 41.6	1,124 - 1,374	215	705	45	1,589	3.4
			Lo	26.3 - 32.1	779 - 952	-	-	-	-	
		60	Hi	39.5 - 48.3	1,244 - 1,520	237	778	50	1,766	
			Lo	27.3 - 33.3	714 - 872	-	-	-	-	
M40C	220	50	Hi	42.5 - 51.9	1,097 - 1,341	226	741	63	2,225	4.4
			Lo	33.5 - 40.9	744 - 910	-	-	-	-	
		60	Hi	52.8 - 64.6	1,166 - 1,425	241	791	67	2,366	
			Lo	34.7 - 42.5	676 - 826	-	-	-	-	

*Hi - Notch 3 / Lo - Notch 1

Wall Fan - Remote Control Series

Usage: Living Room Bedroom Restaurant School

M40M

Remote Control

Easy Angle Adjustment

3-speed Selection

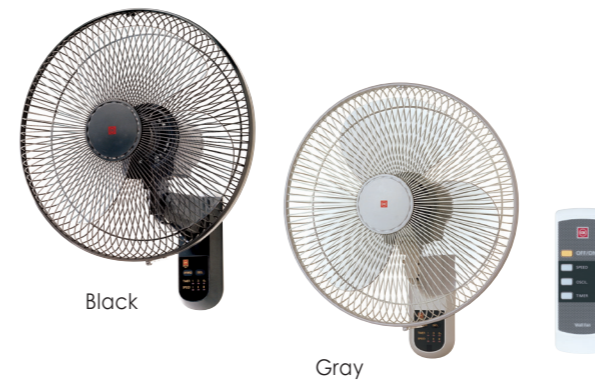

- 3-speed selection
- Remote control for speed, oscillation and off timer
- Soft touch switch panel with LED indicator
- Off timer (1, 3, 6 hours)
- Easy adjustment for tilt angle and oscillation angle
- Thermal fuse to prevent overheating
- Safety shaft cap to prevent fan falling
- Permanently lubricated ball bearing equipped
- Transparent plastic blade
- Colour option: Gray or Black

Adjustment of Tilt Angle and Oscillation Angle

“One-touch” adjustment of tilt

The airflow can be adjusted upward or downward by simply moving the guard up or down as shown in the figure. Adjust the angle of the fan only after first confirming that it has stopped rotating.

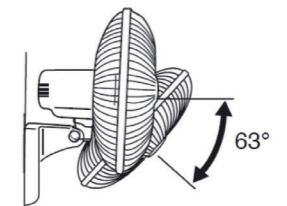

Double oscillation

To change the direction of the air flow, simply push the fan guard to the desired position.

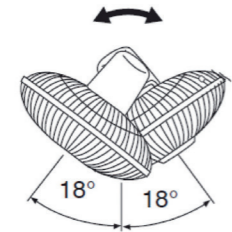

Installation

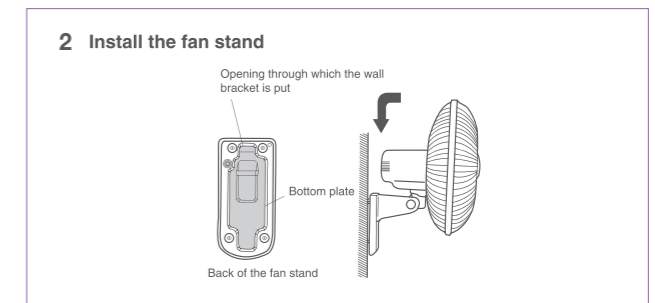
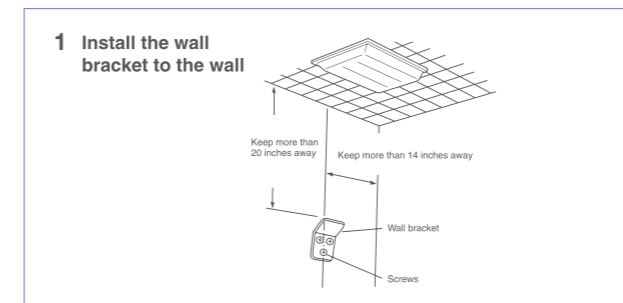

Specification

Model	Voltage [V]	Frequency [Hz]	*	Consumption [W]	RPM	Air Velocity		Air Volume		Weight [kg]
						[m/min]	[ft/min]	[m³/min]	[ft³/min]	
M40M	220	50	Hi	46.8 - 57.2	1,055 - 1,289	228	748	63	2,225	4.4
			Lo	37.9 - 46.3	688 - 840	-	-	-	-	
		60	Hi	56.1 - 68.5	1,094 - 1,337	237	778	65	2,295	
			Lo	37.9 - 46.3	625 - 763	-	-	-	-	

*Hi - Notch 3 / Lo - Notch 1

Wall Fan - Big Wall Fan

Usage: Restaurant School Wet Market Shopping Street

YU50X

Guide Vane Design

Aluminium Blades

3-speed Selection



- Guide Vane design generates strong and focus air flow up to 10 m distance
- Aluminum blades for stronger air flow and durability
- Added angle adjust bolt for extra stability on the fan's knee joint
- Full automatic oscillation
- 3-speed ON/OFF pull switch
- New and modern Front Guard Design

New Guide Vane

Guide Vane shape is matched to intake flow, minimizing pressure loss.

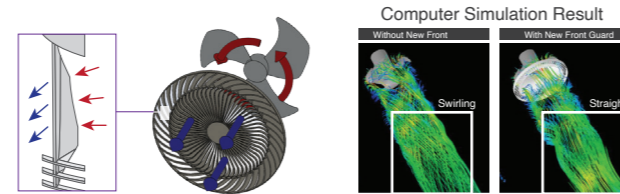

Guide Vane
Change swirling flow to straight restrain flow spreading

New Metal Blade Design

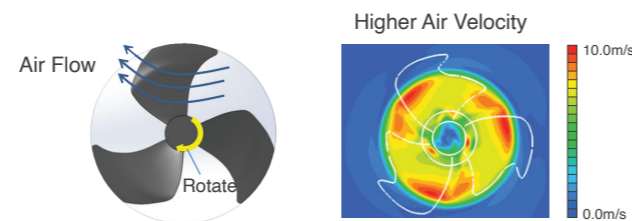

New Guide Vane and metal blade design bring larger air volume and higher air velocity to reach further distance.

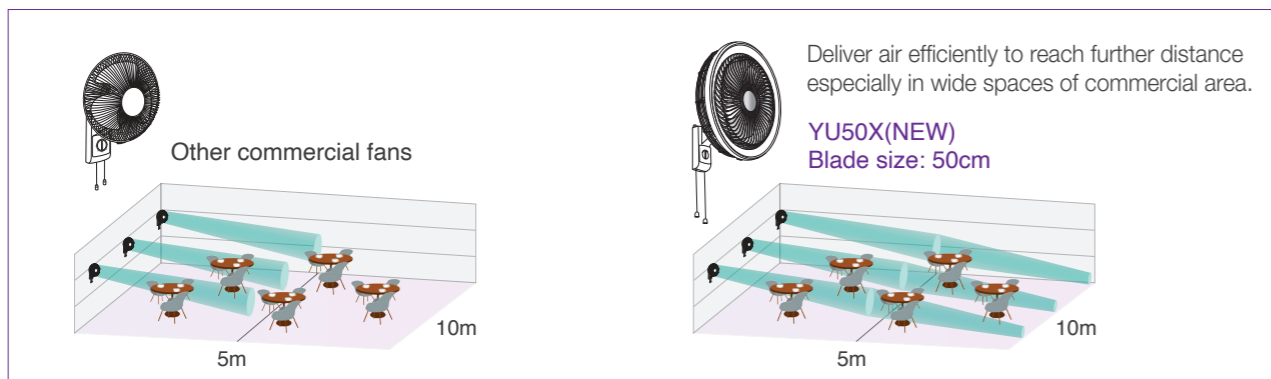

Specification

Model	Voltage [V]	Frequency [Hz]	*	Consumption [W]	RPM	Air Velocity		Air Volume		Weight [kg]
						[m/min]	[ft/min]	[m³/min]	[ft³/min]	
YU50X	220	50	Hi	63	1,230	280	919	100	3,531	4.4
			Lo	53	850	-	-	-	-	
			Hi	67	1,260	290	951	105	3,708	
			Lo	56	880	-	-	-	-	
	230	50	Hi	70	1,280	300	984	110	3,885	
			Lo	60	940	-	-	-	-	
	240	50	Hi	60	1,200	290	951	115	4,061	
			Lo	51	920	-	-	-	-	
	220	60	Hi	76	1,220	295	968	120	4,238	
			Lo	53	800	-	-	-	-	

*Hi - Notch 3 / Lo - Notch 1

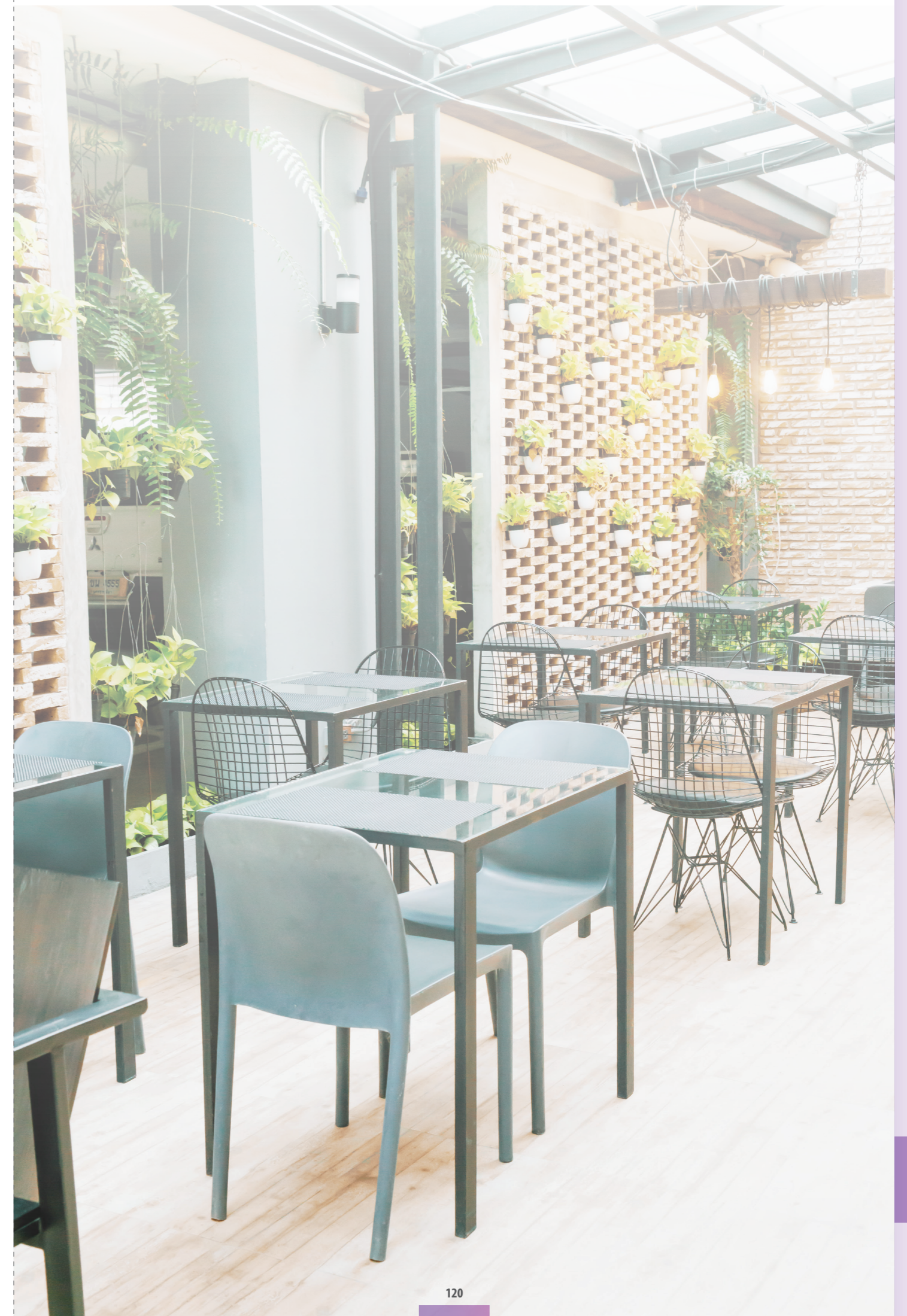

Ventilation Product Specification Summary

■ Ceiling Mount Type Ventilation Fan

Series	Model	Voltage [V]	Frequency [Hz]	Speed	Air Volume		Consumption [W]	Noise [dB(A)]	Weight [kg]	Installation Space [mm]	Duct Size [mm]			
					[CMH]	[CFM]								
DC Motor Series	24JRB	220-240	60	Hi	160	94	8	31	2.9	240 x 240	Ø100			
				Lo	120	71	5.2	26						
		220-230	50	Hi	160	94	8	31						
				Lo	120	71	5.2	26						
	24JAB	220-240	50	Hi	160	94	8	31	2.9	240 x 240	Ø100			
				Lo	120	71	5.2	26						
		220-230	60	Hi	160	94	8	31						
				Lo	120	71	5.2	26						
Super Quiet Series	17CUH	220	50	-	85	50	7.5	23	1.7	177 x 177	Ø100			
			60	-	85	50	10	24						
		230	50	-	85	50	8.5	24.5						
			60	-	85	50	10	24						
		240	50	-	90	53	9.5	26						
			60	-	90	53	9.5	26						
	24CUH	220	50	-	140	82	10.5	25	2.7	240 x 240	Ø100			
			60	-	150	88	13.5	26.5						
		230	50	-	150	88	11	26						
			60	-	150	88	13.5	26.5						
		240	50	-	160	94	12	27						
			60	-	160	94	12	27						
	24CDH	220	50	-	170	100	13.5	28.5	2.7	240 x 240	Ø100			
			60	-	180	106	15	30						
		230	50	-	180	106	15	30						
			60	-	180	106	19	31						
		240	50	-	190	112	16.5	31.5						
			60	-	190	112	16.5	31.5						
	24CHH	220	50	Hi	330	194	28	34	4.4	270 x 270	Ø150			
				Lo	260	153	23	30						
			60	Hi	330	194	33	34						
				Lo	270	159	26	31						
		230	50	Hi	340	200	31.5	35						
				Lo	275	162	25.5	31.5						
240			50	Hi	360	212	34	36.5						
				Lo	290	171	27.5	32						
32CDH		220	50	Hi	430	253	42	36				5.2	320 x 320	Ø150
				Lo	300	177	32	28						
			60	Hi	410	241	48	35.5						
				Lo	285	168	33	27.5						
	230	50	Hi	440	259	46	37.5							
			Lo	315	185	34	29							
		240	50	Hi	470	277	50	38.5						
				Lo	330	194	38	30						

■ Ceiling Mount Type Ventilation Fan

Series	Model	Voltage [V]	Frequency [Hz]	Speed	Air Volume		Consumption [W]	Noise [dB(A)]	Weight [kg]	Installation Space [mm]	Duct Size [mm]		
					[CMH]	[CFM]							
Standard Series	38CDG 38CDG 05	220	50	Hi	640	377	90	44	9.7	385 x 385	Ø150		
				Lo	430	253	66	35					
			60	Hi	630	371	98	43.5					
				Lo	410	241	66.4	34.5					
		230	50	Hi	675	397	96	46					
				Lo	440	259	72	36					
			240	50	Hi	700	412	104				47	
					Lo	470	277	78				37	
	38CHG	220	50	Hi	800	471	122	49.5	10.4	385 x 385	Ø150		
				Lo	525	309	89	39.5					
			60	Hi	790	465	138	49					
		230	50	Lo	500	294	90	39					
				Hi	800	471	122	49					
		240	50	Lo	470	277	84	37					
Hi	835			491	132	50							
Metal Series	24CMUA	220	50	-	90	53	11	25	3.9	240 x 240	Ø100		
			60	-	100	59	12	26					
			50	-	95	56	12	25.5					
	240	60	-	100	59	13	26						
			24CMHA	220	50	-	180	106	20	37	3.9	240 x 240	Ø100
					60	-	180	106	23	37			
				230	50	-	190	112	22	37.5			
	60	-	200		118	25	38						
	27CMHA	220	50	-	360	212	35	37	5.9	270 x 270	Ø150		
				-	380	224	43	37.5					
			230	50	-	380	224	38				37.5	
		240	50	-	400	235	43	38					
				-	400	235	43	38					

Note:

- 1.The value of power consumption, air volume and noise are specified at the static pressure of 0 Pa.
- 2.The value of air volume is the mean value which is measured by our company.
- 3.The value of noise level is measured at 1m apart from the left, the right and the front of product, then get the average of three values.
- 4.The value of noise level is A weight average sound pressure level, the mean value is measured by our company.

Ventilation Product Specification Summary

Cabinet Fan (In-line Fan)

Model	Voltage [V]	Frequency [Hz]		Air Volume		Consumption [W]	Noise [dB(A)]	Weight [kg]	Duct Size [mm]	Impeller Diameter [mm]
				[CMH]	[CFM]					
12NSB	220	50	Hi	180	106	18	21	5.5	Ø100	128
			Lo	145	85	17	17			
	60	Hi	190	112	23	22				
		Lo	145	85	19	18				
	230	50	Hi	180	106	20	21			
			Lo	150	88	18	18			
240	50	Hi	185	109	22	22				
		Lo	155	91	19	20				
15NSB	220	50	Hi	340	200	33	25	6.5	Ø150	128
			Lo	275	162	29.5	22			
	60	Hi	370	218	42	27				
		Lo	260	153	33	22				
	230	50	Hi	340	200	35	25			
			Lo	280	165	31	22			
240	50	Hi	350	206	37	26				
		Lo	290	171	33	24				
18NSB	220	50	Hi	500	294	60	29	8.5	Ø150	158
			Lo	405	238	55	27			
	60	Hi	490	288	73	30				
		Lo	385	277	62.5	26				
	230	50	Hi	500	294	65	30			
			Lo	420	247	58.5	28			
240	50	Hi	510	300	68	31				
		Lo	430	253	63.5	28				
18NFB	220	50	Hi	770	453	91	31	10.0	Ø200	158
			Lo	620	365	80	29			
	60	Hi	760	447	119	32				
		Lo	580	341	87	28				
	230	50	Hi	770	453	96	32			
			Lo	620	365	82	29			
240	50	Hi	780	459	104	33				
		Lo	640	377	86	29				
20NSB	220	50	Hi	920	541	120	32	14.0	Ø200	178
			Lo	720	424	113	29			
	60	Hi	860	506	159	32				
		Lo	620	365	128	26				
	230	50	Hi	930	547	125	33			
			Lo	750	441	120	30			
240	60	Hi	940	553	135	34				
		Lo	790	465	125	31				
23NLB	220	50	Hi	1,200	706	230	40	18.0	Ø200	220
			Lo	900	530	170	34			
	60	Hi	1,100	647	310	40				
		Lo	800	471	190	32				
	230	50	Hi	1,200	706	250	40			
			Lo	900	530	180	35			
240	50	Hi	1,250	736	260	41				
		Lo	950	559	190	37				
25NSB	220	50	Hi	1,700	1,001	345	41	24.0	Ø250	220
			Lo	1,380	812	265	38			
	60	Hi	1,650	971	425	41				
		Lo	1,200	706	300	39				
	230	50	Hi	1,720	1,012	350	42			
			Lo	1,380	812	270	39			
240	50	Hi	1,750	1,030	370	44				
		Lo	1,450	853	290	40				
25NFB	220	50	Hi	1,900	1,118	390	43	24.0	Ø250	220
			Lo	1,600	942	325	40			
	60	Hi	1,810	1,065	520	42				
		Lo	1,400	824	380	41				
	230	50	Hi	1,910	1,124	410	45			
			Lo	1,600	942	335	41			
240	50	Hi	1,920	1,130	430	46				
		Lo	1,620	953	360	42				

Low Noise Type Cabinet Fan (Three Phase Series) Model Comparison

Model	Phase	Voltage [V]	Frequency [Hz]	Air Volume		Consumption [W]	RPM	Noise [dB(A)]	Weight [kg]	Duct Size [mm]	Impeller Diameter [mm]
				[CMH]	[CFM]						
25SWC	3	380	50	4,000	2,354	940	1,375	43	60	250 x 250	250
			60	4,500	2,648	1,450	1,530	45			
25SMC	3	380	50	5,200	3,060	1,180	1,345	45	60	250 x 700	250
			60	5,500	3,237	1,750	1,470	46			
28NXC	3	380	50	2,600	1,530	600	1,295	44	28	Ø250	280
			60	2,650	1,560	840	1,380	45			

Test Condition

- Air volume, electric characteristic and noise are specified at the static pressure of 0 Pa
- The values of noise level is A weighted average sound pressure level, the mean values are measured by our company, within +3 to -7 dB tolerance
- The values of noise level are measured at 1.5 m apart from the side of fan body when ducts are connected on outlet side
- The values of air volume are the mid-points of results measured by our company, within ±10% tolerance

Industrial Type Ventilation Fan

Model	Voltage [V]	Frequency [Hz]	Air Volume		Consumption [W]	Noise [dB(A)]	Weight [kg]
			[CMH]	[CFM]			
25GSE	220	50	1,280	753	41	44	2.0
		60	1,440	848	57	46	
	230	50	1,280	753	43	44	
		240	50	1,280	753	44	
30GSE	220	50	2,150	1,265	87	49	2.5
		60	2,390	1,407	119	51	
	230	50	2,150	1,265	92	49	
		240	50	2,150	1,265	98	
35GSE	220	50	2,950	1,736	113	51	2.9
		60	3,380	1,989	161	54	
	230	50	2,950	1,736	118	51	
		240	50	2,950	1,736	122	
40GSE	220	50	3,900	2,295	141	54	19.0
		60	4,890	2,878	270	58	
	230	50	3,900	2,295	146	54	
		240	50	3,900	2,295	151	
45GSC	220	50	5,200	3,061	227	51	19.0
		60	5,970	3,514	325	54	
	230	50	5,430	3,196	235	51	
		240	50	5,460	3,214	241	
50GSC	220	50	6,130	3,608	249	47	22.5
		60	7,100	4,179	326	51	
	230	50	6,420	3,779	258	47	
		240	50	6,480	3,814	271	
60GSC	220	50	8,040	4,732	245	50	34.0
		60	9,410	5,539	361	54	
	230	50	8,460	4,979	258	50	
		240	50	8,490	4,997	263	
45GTC	380	50	5,520	3,249	220	52	18.5
		60	6,420	3,779	330	56	
50GTC	380	50	6,960	4,097	320	54	28.5
		60	8,010	4,715	475	58	
60GTC	380	50	9,420	5,544	310	49	34
		60	10,920	6,427	450	53	

Note: RPM data is for reference only. Values may vary depending on different conditions.

1. The value of power consumption, air volume and noise are specified at the static pressure of 0 Pa.
2. The value of air volume is the mean value which is measured by our company.
3. The value of noise level is measured at 1m apart from the left, the right and the front of product, then get the average of three values.
4. The value of noise level is A weight average sound pressure level, the mean value is measured by our company.

Ventilation Product Specification Summary

Wall Mount Type Ventilation Fan

Series	Model	Voltage [V]	Frequency [Hz]	Air Volume		Consumption [W]	Noise [dB(A)]	Weight [kg]	Installation Space [mm]	
				[CMH]	[CFM]					
Metallic Series	20ASB 20ASB 05	220	50	516	304	17	37.5	3.3	250 x 250	
			60	612	360	21.5	40.6			
		230	50	528	311	18.1	38.1			
	25ASB 25ASB 05	220	50	858	505	25	39.1	3.8	300 x 300	
			60	954	562	30.5	40.6			
		230	50	864	509	27.3	39.3			
	30ASB 30ASB 05	220	50	1,182	696	29.5	39.2	4.4	350 x 350	
			60	1,164	685	34.5	39			
		230	50	1,248	735	31.7	40.6			
	Automatic Shutter Series	15AAQ1	220	50	288	170	15	31	1.4	175 x 175
				60	306	180	19	34		
			230	50	294	173	17	33		
240			50	306	180	19	33			
20AUA		220-230	50	590-610	347-359	18-19.5	36-36.5	1.9	250 x 250	
			60	590-620	347-365	18-21.5	36-37			
		220	60	680	400	22	39			
		230	60	710	418	23.5	40			
25AUA		220-230	50	950-970	559-571	25-27	38-38.5	2.3	300 x 300	
			60	950-990	559-571	25-27	38-39			
		220	60	990	571	31	39			
		230	60	1,040	612	35	41			
30AUA		220-230	50	1,200-1,250	706-736	28-30	37-38	2.6	350 x 350	
			60	1,200-1,300	706-765	28-32.5	37-38			
		220	60	1,200	706	33	37			
		230	60	1,300	765	36	39			
20AUH		220	50	580	341	22	38	2.0	250 x 250	
			60	650	383	29	42			
25AUH		220	50	920	541	29	39	2.4	300 x 300	
			60	940	553	33	39			
30AUH 11		220	50	1,200	706	29	39	2.7	350 x 350	
			60	1,140	671	33	38			
Automatic Shutter Louver Series		20ALA	220-230	50	550-555	324-327	18-19.5	38-38.5	2.0	250 x 250
				60	550-560	324-330	18-21.5	38-39		
	220		60	610	359	22	42.5			
	230		60	630	371	23.5	44			
	25ALA	220-230	50	840-860	494-506	25-27	40.5-42	2.5	300 x 300	
			60	840-880	494-518	25-30	40.5-43			
		220	60	860	506	31	42			
		230	60	910	536	34	45			
	30ALA	220-230	50	1,000-1050	589-618	28-30	39-40	2.9	350 x 350	
			60	1,000-1,100	589-647	28-32.5	39-41			
		220	60	1,000	589	33	40			
	20ALH	220	50	546	321	22	40	2.2	250 x 250	
			60	600	353	29	44			
	25ALH	220	50	835	491	29	43	2.7	300 x 300	
			60	846	498	33	43			
	30ALF 11	220	50	935	550	29	43	3.1	350 x 350	
			60	915	539	33	43			

- Note:
- 1.The value of power consumption, air volume and noise are specified at the static pressure of 0 Pa.
 - 2.The value of air volume is the mean value which is measured by our company.
 - 3.The value of noise level is measured at 1m apart from the left, the right and the front of product, then get the average of three values.
 - 4.The value of noise level is A weight average sound pressure level, the mean value is measured by our company.

Wall Mount Type Ventilation Fan

Series	Model	Voltage		Air Volume [CMH]	Consumption [W]	RPM	Noise [dB(A)]	Weight [kg]	Installation Space [mm]	Wall Thickness [mm]
		[V]	[Hz]							
Bathroom Series	10EGKB	220	50	76	4.3	2,660	33	1.0	Ø130~140	100-150
			60	612	360	21.5	40.6			
		230	50	77	4.6	2,675	33			
	15EGKB	220	50	162	5.7	2,265	36	1.3	Ø175~185	100-150
			60	165	6.1	2,330	37			
		240	50	165	6.5	2,390	37			
	10EGSB	220	50	76	4.3	2,665	35	0.8	Ø120~125	>205
			60	87	4.7	3,140	37.5			
		230	50	77	4.6	2,670	35			
		240	50	77	5.0	2,685	35			
	15EGSB	220	50	155	5.7	2,130	36	1.0	Ø165~170	>240
			60	180	6.1	2,470	40			
		230	50	160	6.1	2,230	37			
	10BAQ1	220	50	76.3	15	1,250	40.1	1.7	155 x 205	-
			60	72.9	17	1,200	39.8			
		230	50	80.3	16	1,300	41.2			
		240	50	84.9	17.5	1,385	42			

- Note: RPM data is for reference only, values may vary subject to different conditions
- Test Condition
- Air volume, electric characteristic and noise are specified at the static pressure of 0 Pa
 - The values of noise level is A weighted average sound pressure level, the mean values are measured by our company, within +3 to -7 dB tolerance
 - The values of noise level are measured at 1 m apart from the side of fan body when ducts are connected on outlet side
 - The values of air volume are the mid-points of results measured by our company, within ±10% tolerance

Ventilation Product Specification Summary

Window Mount Type Ventilation Fan

Series	Model	Voltage [V]	Frequency [Hz]	Air Volume		Consumption [W]	Noise [dB(A)]	Weight [kg]	Installation Space [mm]			
				[CMH]	[CFM]							
Electric Shutter Series	15WHCT	220	50	230	135	13	43	1.4	Ø186 - Ø188			
			60	230	135	13	44					
		230	50	230	135	14	43					
			240	50	230	135	15			43		
		20WHCT	220	50	445	262	20			42	2.6	Ø247 - Ø250
				60	480	283	22			45		
	230	50	445	262	21	42						
	240	50	445	262	22	42						
Automatic Shutter Series	15WAA	220	50	210	124	14	43	0.9	Ø186 - Ø188			
			60	222	131	18	44					
		230	50	222	131	15	44					
	15WAA / 15WAAMN	240	50	228	134	16	44					
	20WAA	220	50	380	224	15	42	1.4	Ø247 - Ø250			
			60	380	224	17	42					
		230	50	390	230	16	43					
	20WAA / 20WAAMN	240	50	401	237	17.5	43					
	Cord-Operated Shutter Series	15WUD	220	50	210	124	8.1	35	0.9	Ø186 - Ø188		
				60	200	118	8.9	34				
230			50	220	129	8.8	35					
15WUD / 15WUDMN		240	50	230	135	9.5	36					
20WUD		220	50	360	212	16.4	32	1.1	Ø247 - Ø250			
			60	360	212	19	31					
		230	50	380	224	17.9	34					
20WUD / 20WUDMN		240	50	400	235	19.5	36					

- Note:
- The value of power consumption, air volume and noise are specified at the static pressure of 0 Pa.
 - The value of air volume is the mean value which is measured by our company.
 - The value of noise level is measured at 1m apart from the left, the right and the front of product, then get the average of three values.
 - The value of noise level is A weight average sound pressure level, the mean value is measured by our company.

Energy Recovery Ventilator

Model	Voltage [V]	Frequency [Hz]	Notch	Air Volume		Consumption [W]	External Static Pressure [Pa]	Exchange Efficiency				Noise [dB(A)]	Weight [kg]
				[CMH]	[CFM]			Temperature		Enthalpy			
								Cooling	Heating	Cooling	Heating		
E25DZUA	220	60	SH	250	147	157	90	60	75	61	67	33	30
			H	250	147	148	40	60	75	61	67	33	
			L	150	88	82	0	65	77	70	74	26	
E35DZUA	220	60	SH	350	206	282	100	53	78	66	71.5	37	39
			H	350	206	253	18	53	78	66	71.5	36.5	
			L	255	150	172	0	53	75	63	70	30.5	
E50DZUA	220	60	SH	500	294	376	60	53	78	66	70	38	45
			H	500	294	349	0	53	78	66	70	37.5	
			L	350	206	215	0	58	78	66	69	32	

Test Condition

- The input power, current and exchange efficiency are measured at the standard air volume
- The input power indicated in name plate is the maximum value at the static pressure of 0 Pa
- The noise is measured 1.5 m away from the bottom face of the unit. The noise value measured at the total acoustic room is more than the indicated value in actual operation
- The above parameters are measured according to standard JIS B 8628

Main Body	Size (mm)	650 x 750 x 220	680 x 920 x 230	680 x 1090 x 240
	Weight	30	39	45
	OA Side Duct Diameter	Ø200		
	Duct Diameter RA/SA/EA	Ø150		

Up-Side Down Installation	Up-Side Down Installation
---------------------------	---------------------------

Filter Box	Duct Diameter	Ø200	
	Size (mm)	600 x 385 x 240	600 x 385 x 350

Ventilation Product Specification Summary

Mini Sirocco Fan

Model	Voltage [V]	Frequency [Hz]	Speed	Air Volume [CMH]	Consumption [W]	Noise Level [dB]		Net Weight [kg]
						Inlet	Side	
10CGB	220	50	Hi	154	15	41.0	28.0	1.9
			Lo	115	12	35.5	24.0	
		60	Hi	133	12	36.5	24.0	
			Lo	93	9	28.5	20.0	
	230	60	Hi	143	13	38.0	25.0	
			Lo	100	10	30.5	20.0	
	220-240	50	Hi	134-143	10-11	37.0-39.0	23.0-25.0	
			Lo	110-125	9-10	32.0-35.0	20.0-23.0	
12CGB	220	50	Hi	250	22	44.0	29.0	2.5
			Lo	175	16	32.0	19.0	
		60	Hi	225	25	42.5	29.0	
			Lo	145	18	32.0	21.0	
	230	60	Hi	242	27	44.0	30.0	
			Lo	153	19	34.0	21.5	
	220-240	50	Hi	233-262	23-28	44.5-46.5	29.0-32.0	
			Lo	156-175	19-23	33.0-36.0	18.0-20.0	
14CGB	220	50	Hi	332	35	50.0	34.0	2.8
			Lo	226	28	40.0	26.0	
		60	Hi	260	30	43.0	30.0	
			Lo	200	25	35.5	25.0	
	230	60	Hi	275	33	44.5	31.5	
			Lo	212	28	37.5	26.0	
	220-240	50	Hi	280-315	28-32	44.5-46.5	31.0-33.0	
			Lo	227-265	26-30	40.0-44.0	27.0-31.0	
16CGB	220	50	Hi	509	50	49.0	35.0	5.6
			Lo	405	43	43.5	30.0	
		60	Hi	483	57	48.0	32.0	
			Lo	372	44	41.0	27.0	
	230	60	Hi	503	61	49.0	34.5	
			Lo	393	48	42.5	29.0	
	220-240	50	Hi	509-542	50-56	49.0-51.5	35.0-38.0	
			Lo	405-450	43-48	43.5-46.0	30.0-32.0	

Mini Sirocco Fan

Model	Voltage [V]	Frequency [Hz]	Speed	Air Volume [CMH]	Consumption [W]	Noise Level [dB]		Net Weight [kg]
						Inlet	Side	
17CGB	220	50	Hi	791	86	50.0	36.0	10.1
			Lo	640	70	44.0	31.0	
		60	Hi	752	95	49.0	34.0	
			Lo	612	73	43.5	29.0	
	230	60	Hi	789	104	50.0	35.0	
			Lo	641	80	44.0	31.0	
	220-240	50	Hi	791-875	86-101	50.0-52.5	36.0-39.0	
			Lo	640-705	70-83	44.0-47.0	31.0-32.0	
19CGB	220	50	Hi	947	121	55.0	41.0	10.2
			Lo	857	105	51.5	37.0	
		60	Hi	885	127	52.0	39.0	
			Lo	760	107	48.0	37.0	
	230	60	Hi	931	140	53.5	40.0	
			Lo	791	117	49.5	36.5	
	220-240	50	Hi	919-997	113-130	52.0-54.0	40.0-42.0	
			Lo	804-880	99-115	50.0-52.0	38.0-40.0	
21CGB	220	50	Hi	1420	238	67.0	54.0	14.6
			Lo	1143	182	60.0	47.0	
		60	Hi	1500	328	68.0	57.0	
			Lo	1042	215	58.0	47.0	
	230	60	Hi	1550	342	69.0	57.5	
			Lo	1100	230	59.5	48.0	
	220-240	50	Hi	1420-1435	238-247	66.0-67.0	54.0-55.0	
			Lo	1143-1220	182-197	60.0-62.5	47.0-51.0	

Notes:

- ① The values of rated input, air volume and noise are specified at the static pressure of 0 Pa.
- ② The values of noise level is A weighted average sound pressure level, the mean values are measured by our company, within +3 and -7 tolerance.
- ③ The values of noise level are measured at the 1.5m apart from the inspection panel of the fan body when ducts are connected on both inlet and outlet side. It is based on the assumption that the noise of fan body propagates to room inside.
- ④ The values of air volume are the mid-points of results measured by our company, with ±10% tolerance.

Performance Data Summary

Ceiling Mount Type Ventilation Fan

DC Motor Series: 24JRB

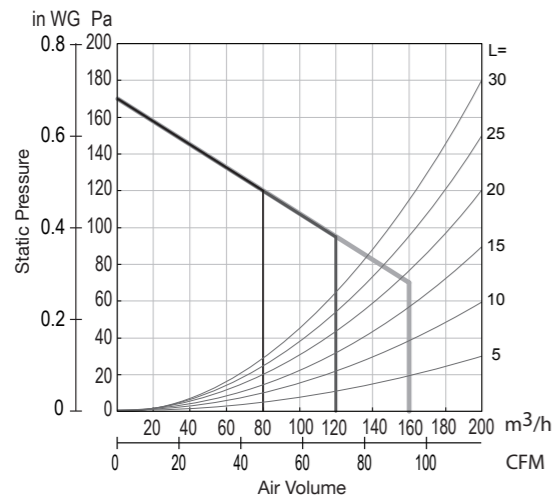

DC Motor Series: 24JAB

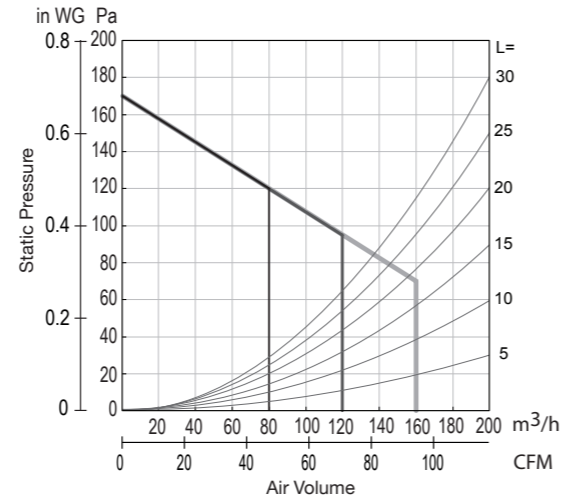

Super Quiet Series: 17CUH

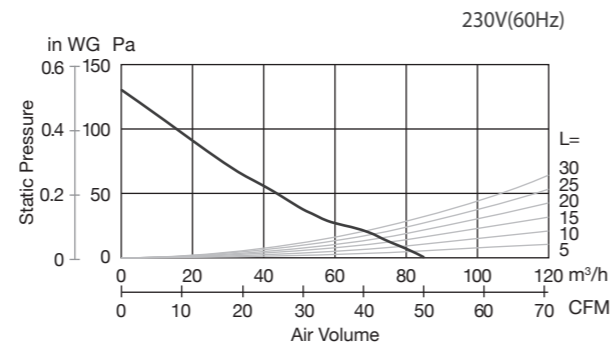
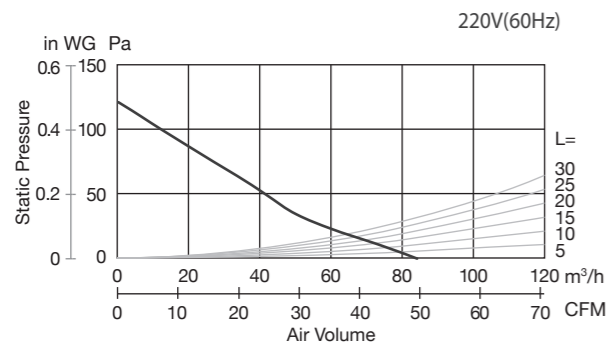
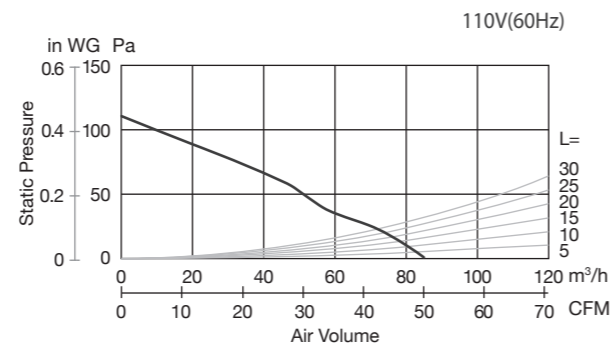
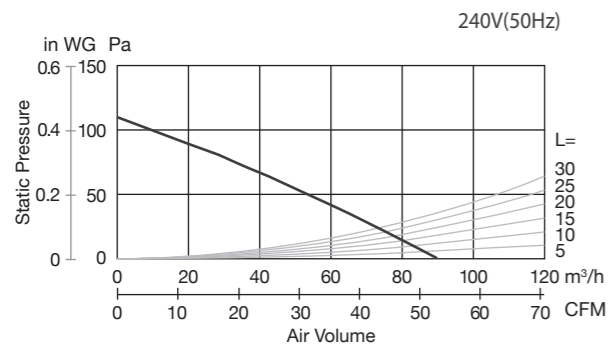
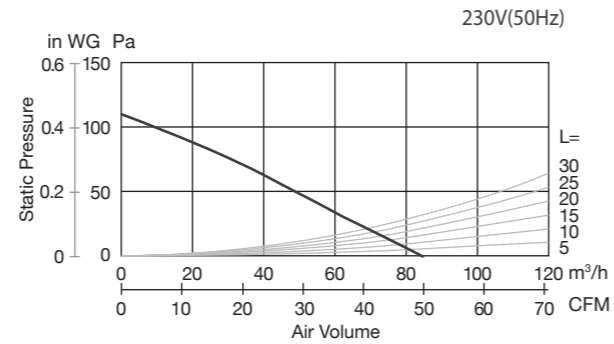
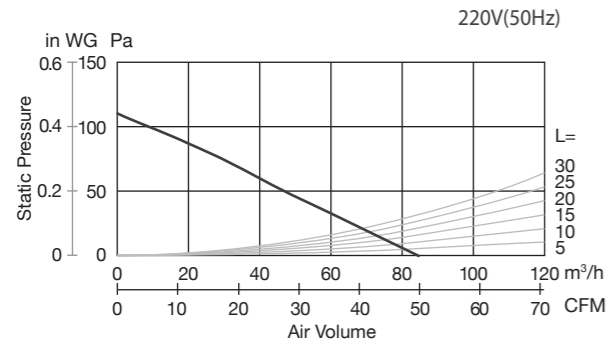

Ceiling Mount Type Ventilation Fan

Super Quiet Series: 24CUH

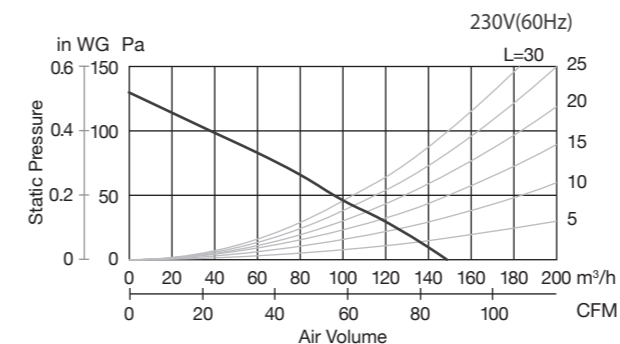
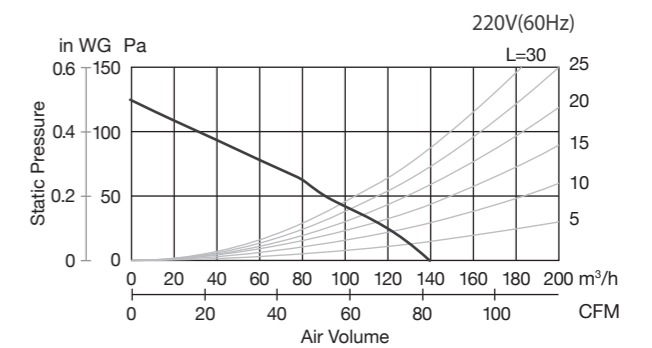
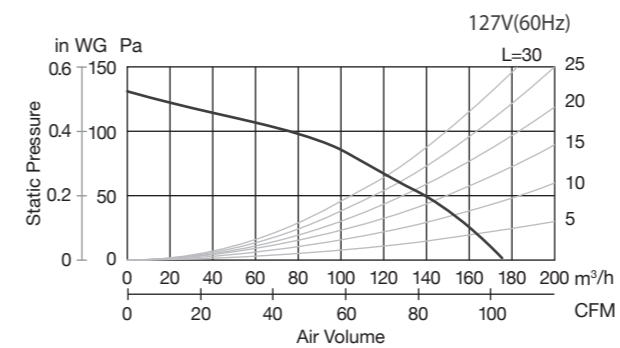
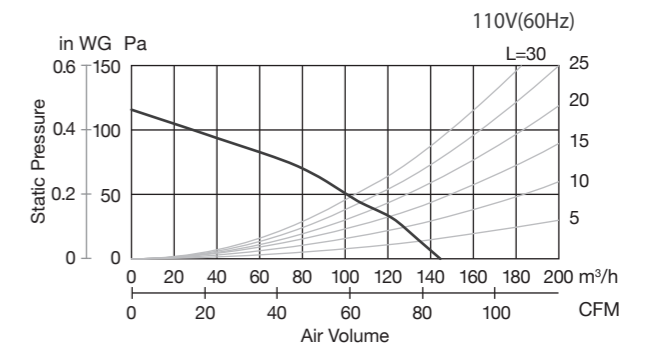
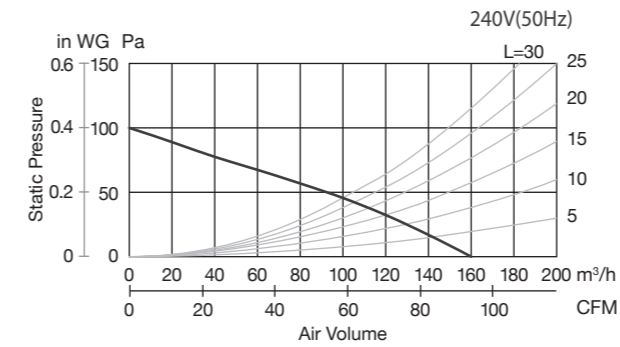
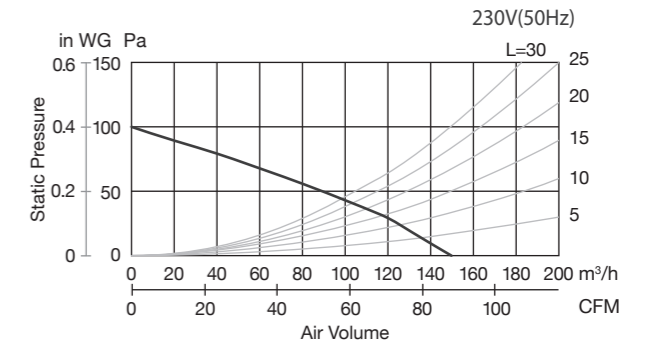
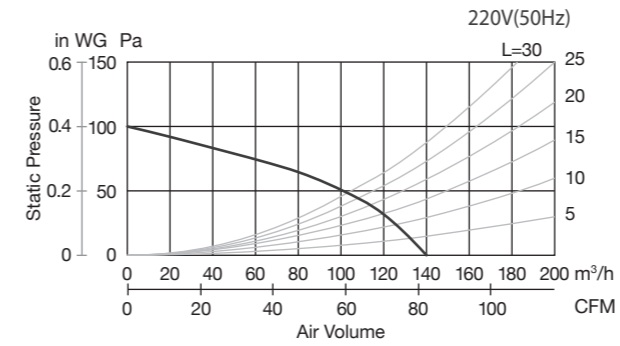

Performance Data Summary

Ceiling Mount Type Ventilation Fan

Super Quiet Series: 24CDH

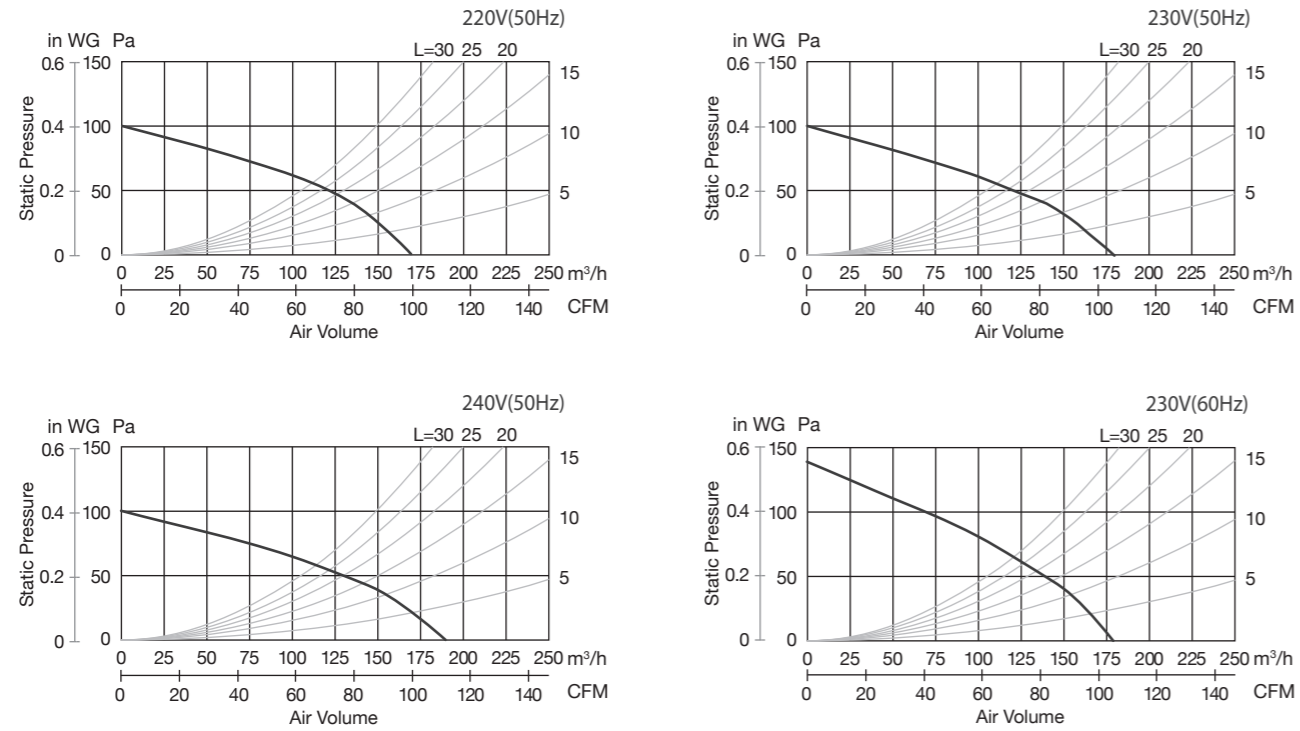

Super Quiet Series: 24CHH

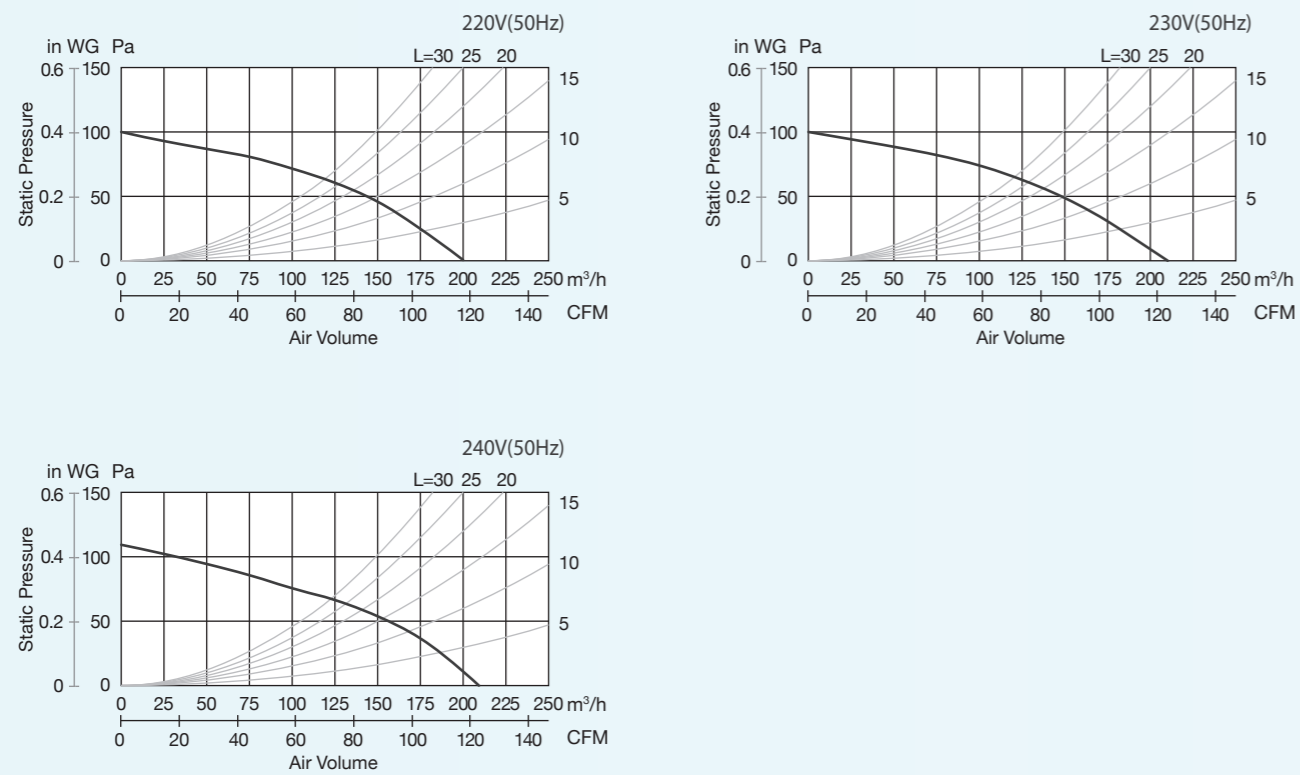

Ceiling Mount Type Ventilation Fan

Super Quiet Series: 24CXH

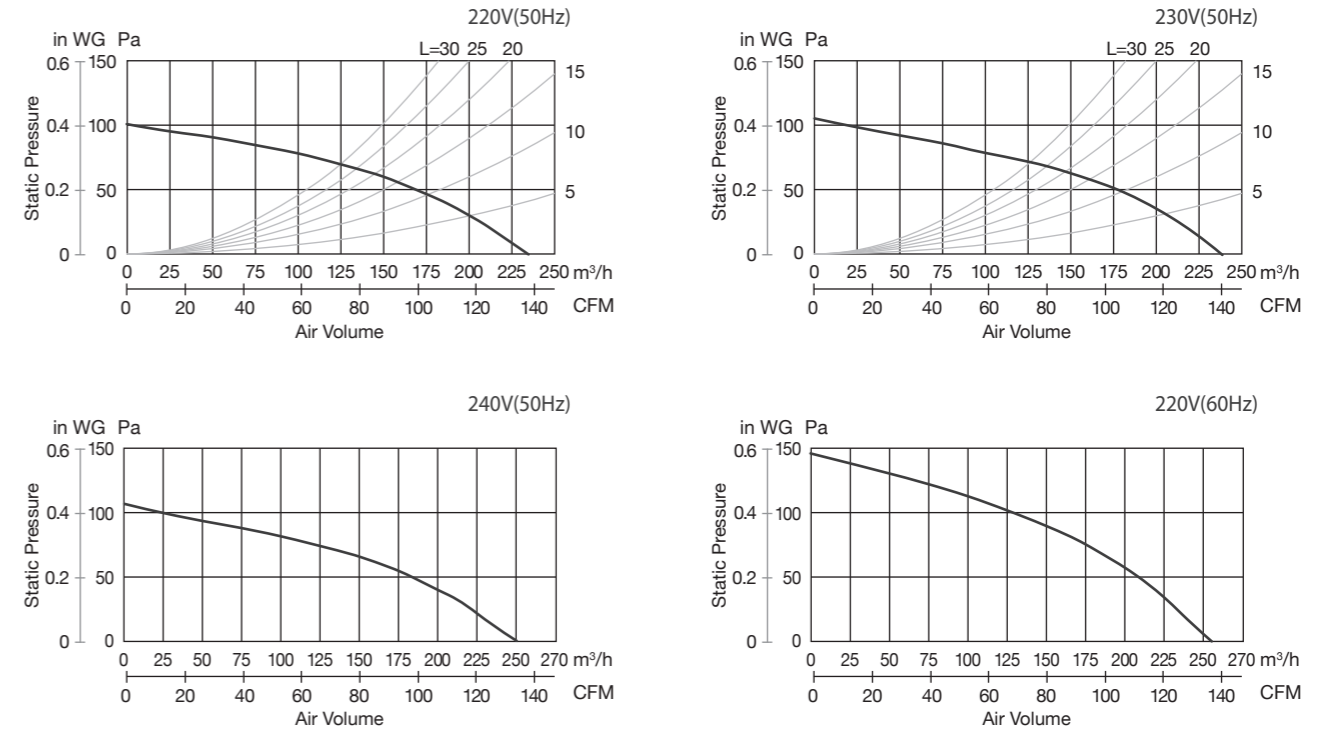

Super Quiet Series: 24CHH

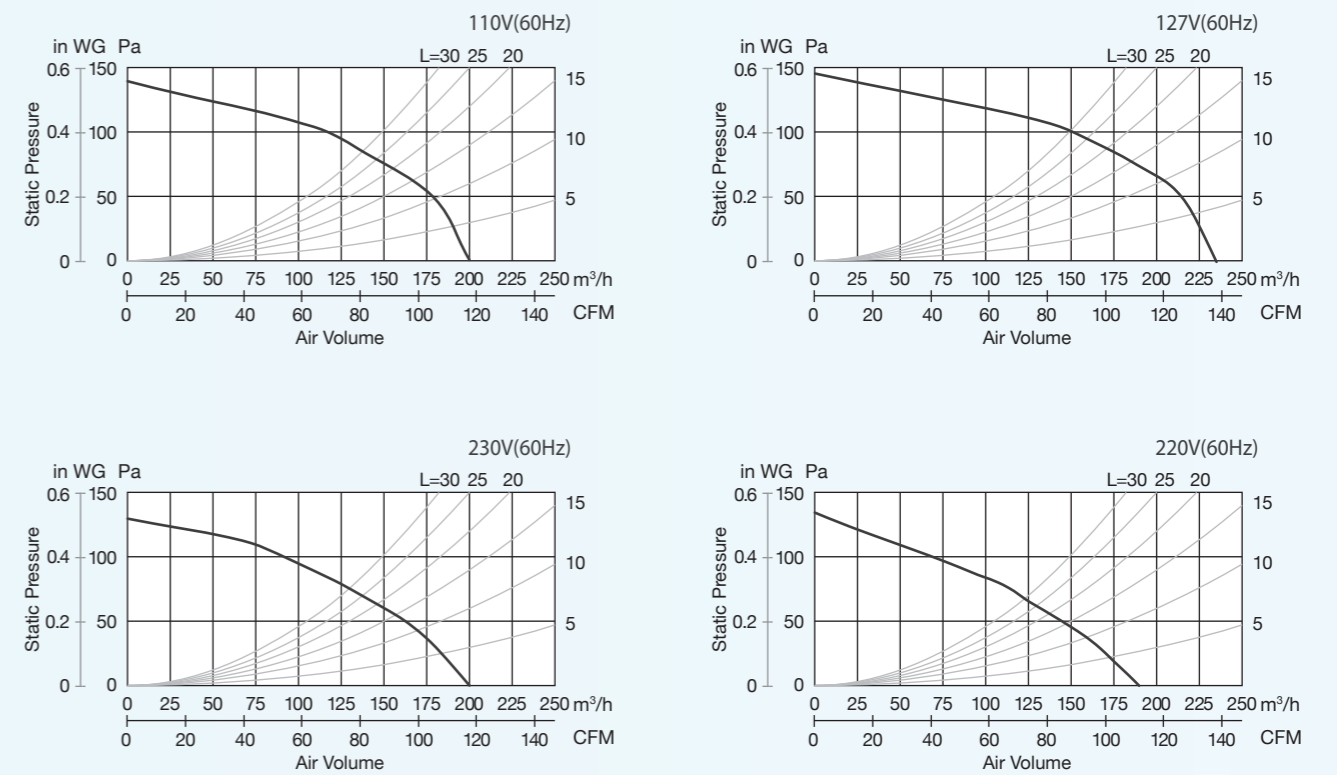

Performance Data Summary

Ceiling Mount Type Ventilation Fan

Super Quiet Series: 27CHH

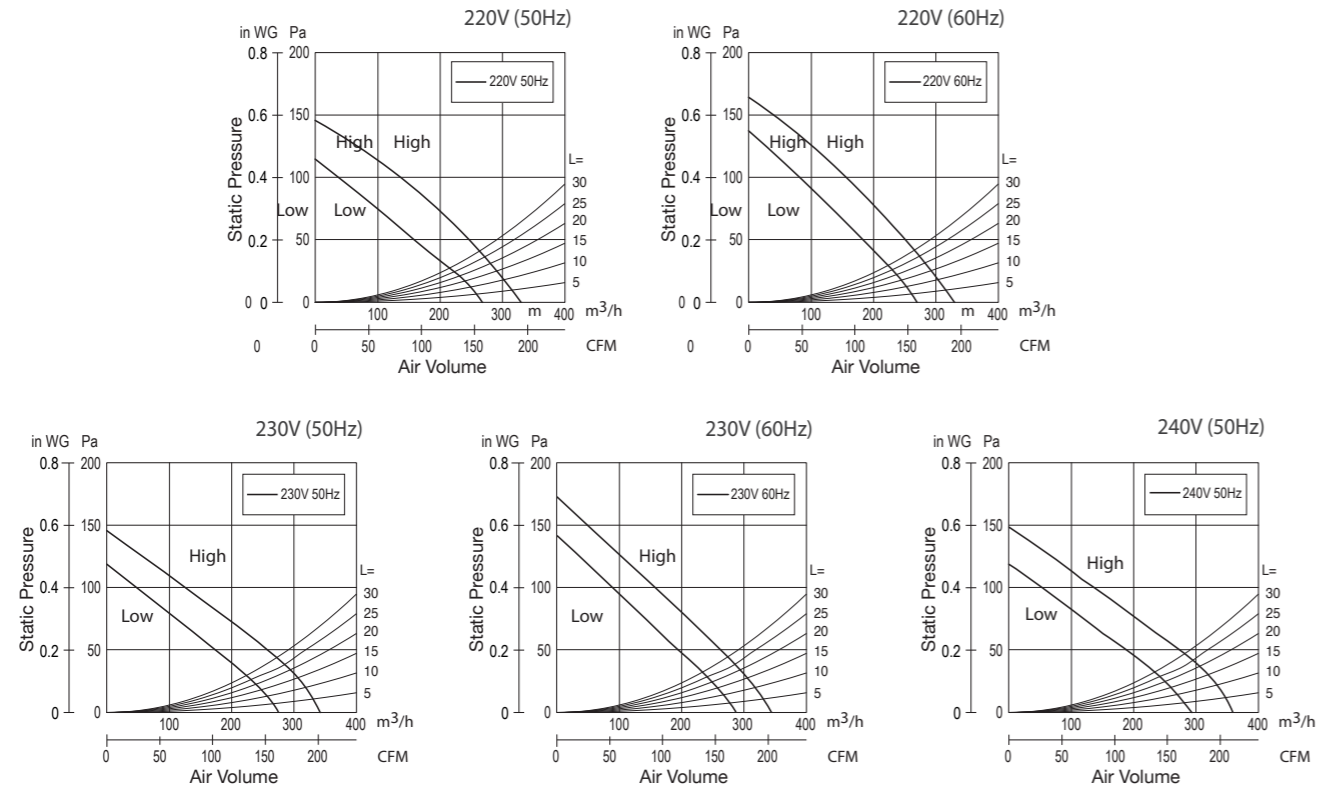

Super Quiet Series: 32CDH

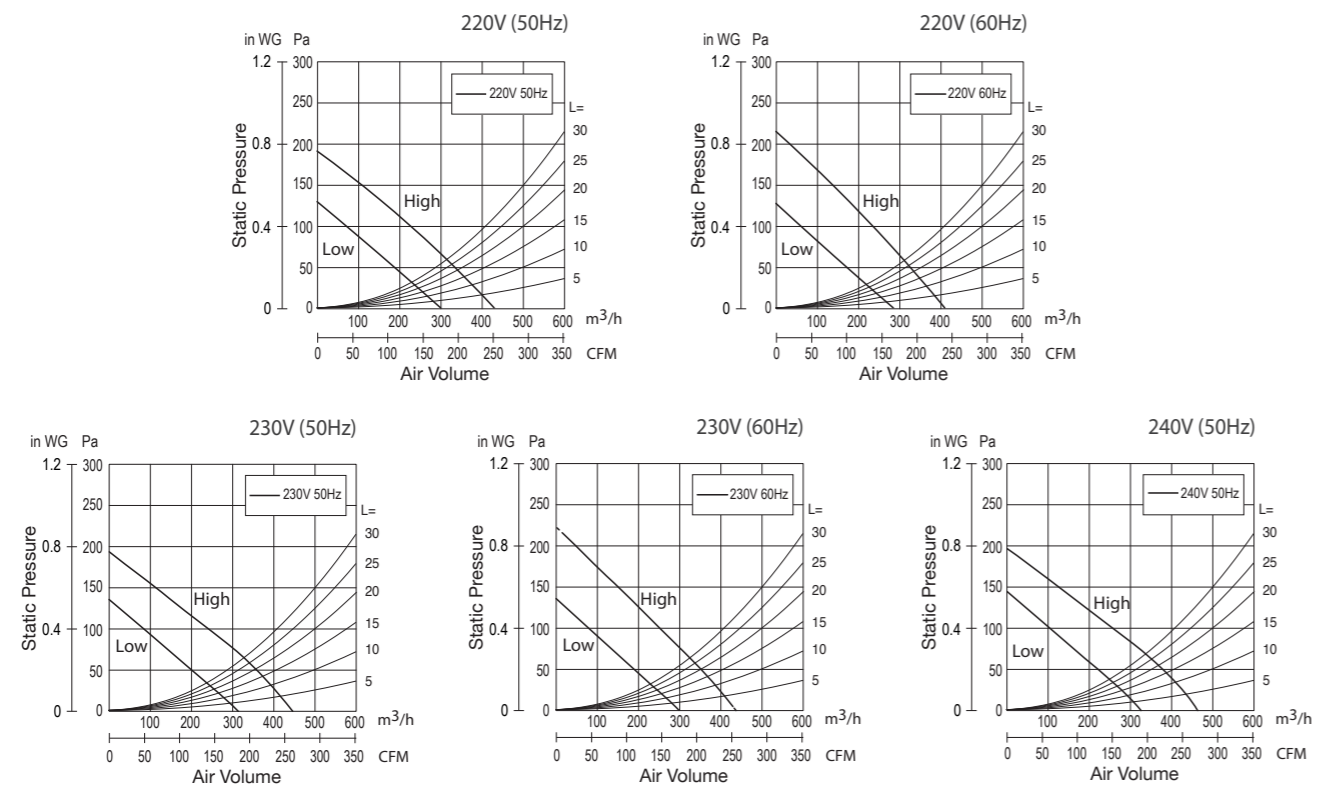

Ceiling Mount Type Ventilation Fan

Standard Series: 38CDG / 38CDG 05

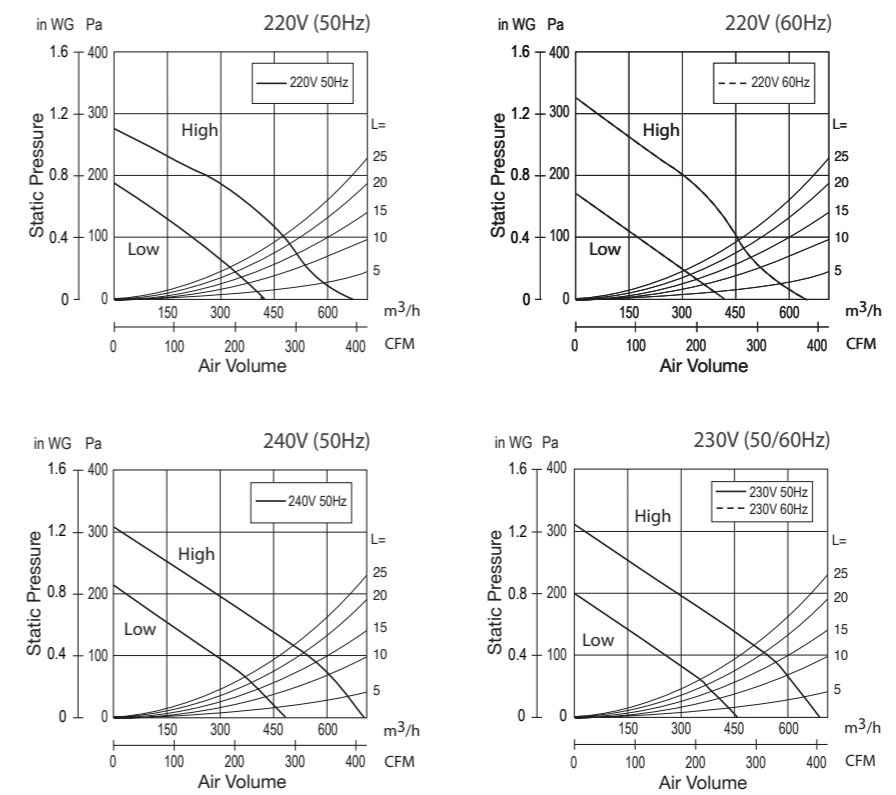

Standard Series: 38CHG

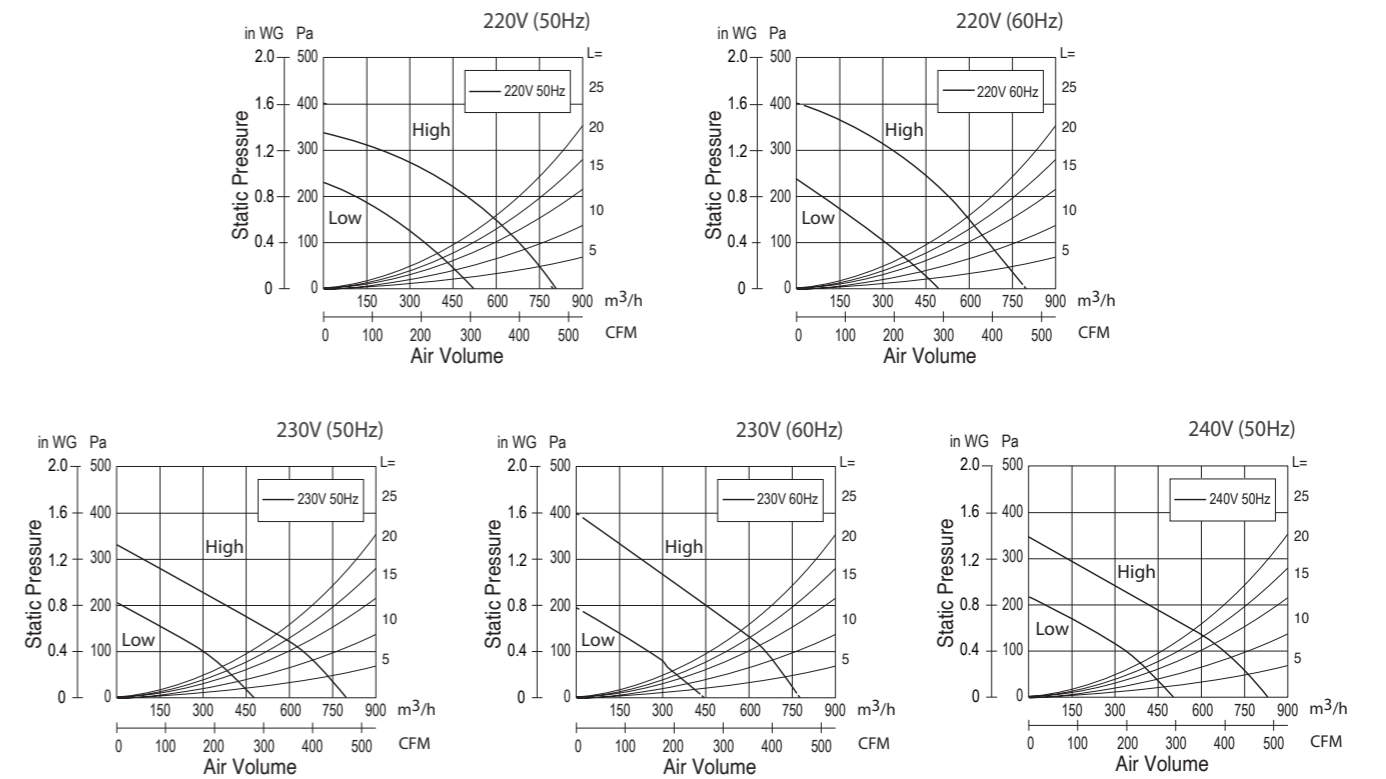

Performance Data Summary

Wall Mount Type Ventilation Fan

Automatic Shutter Series: 20AUA

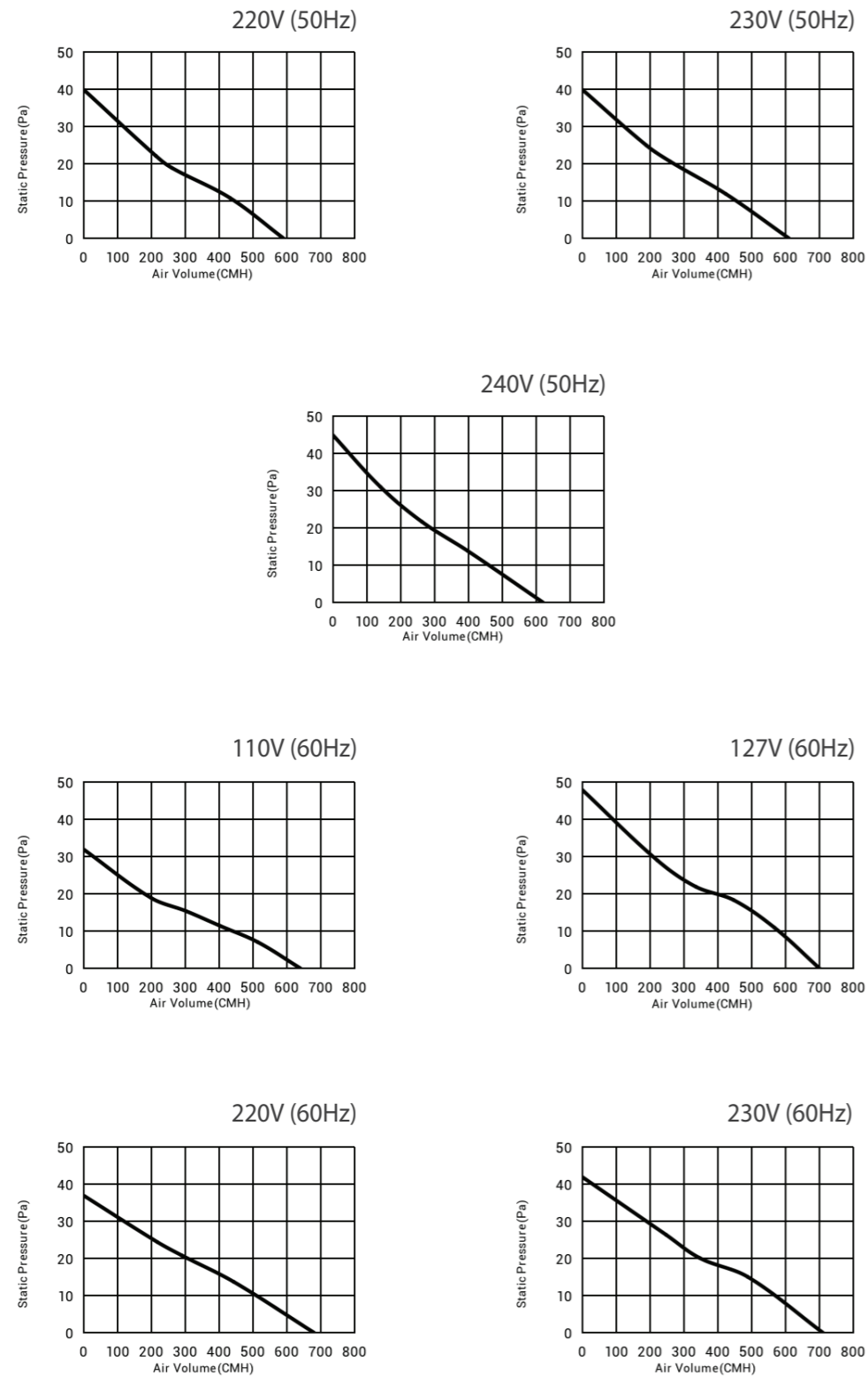

Wall Mount Type Ventilation Fan

Automatic Shutter Series: 25AUA

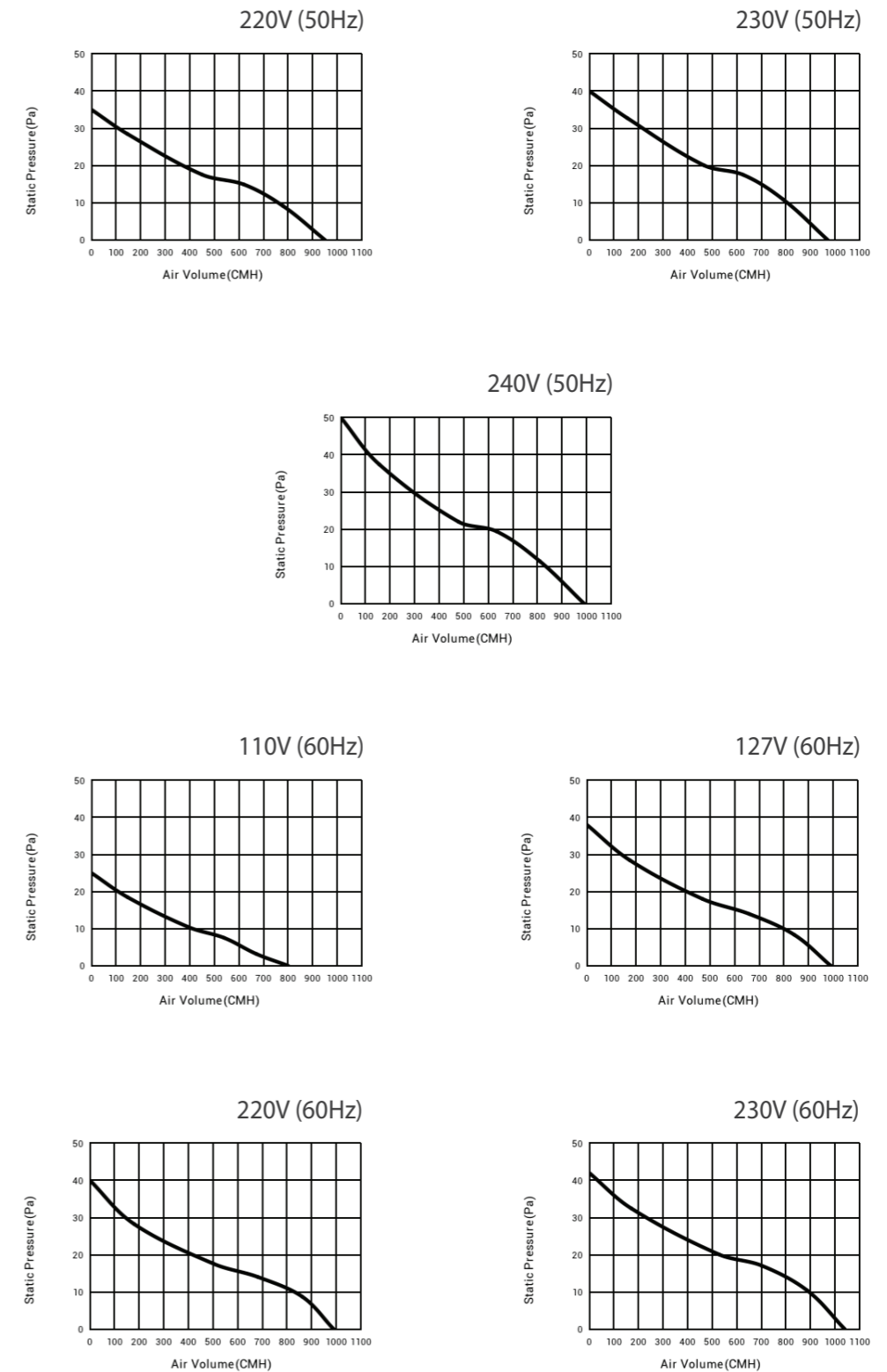

Performance Data Summary

Wall Mount Type Ventilation Fan

Automatic Shutter Series: 30AUA

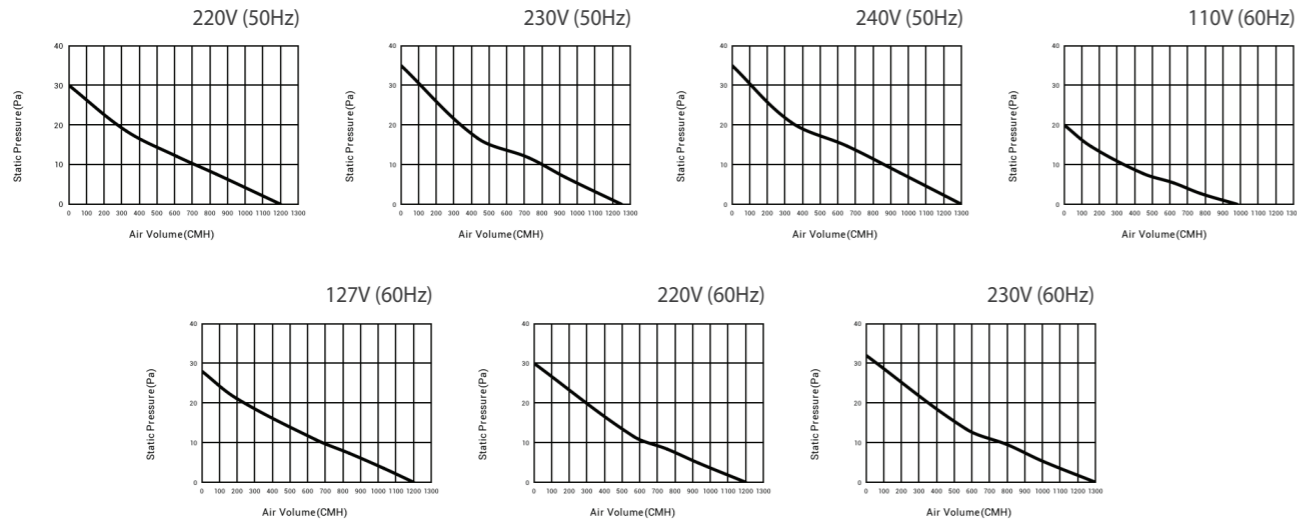

Automatic Shutter Louver Series: 20ALA

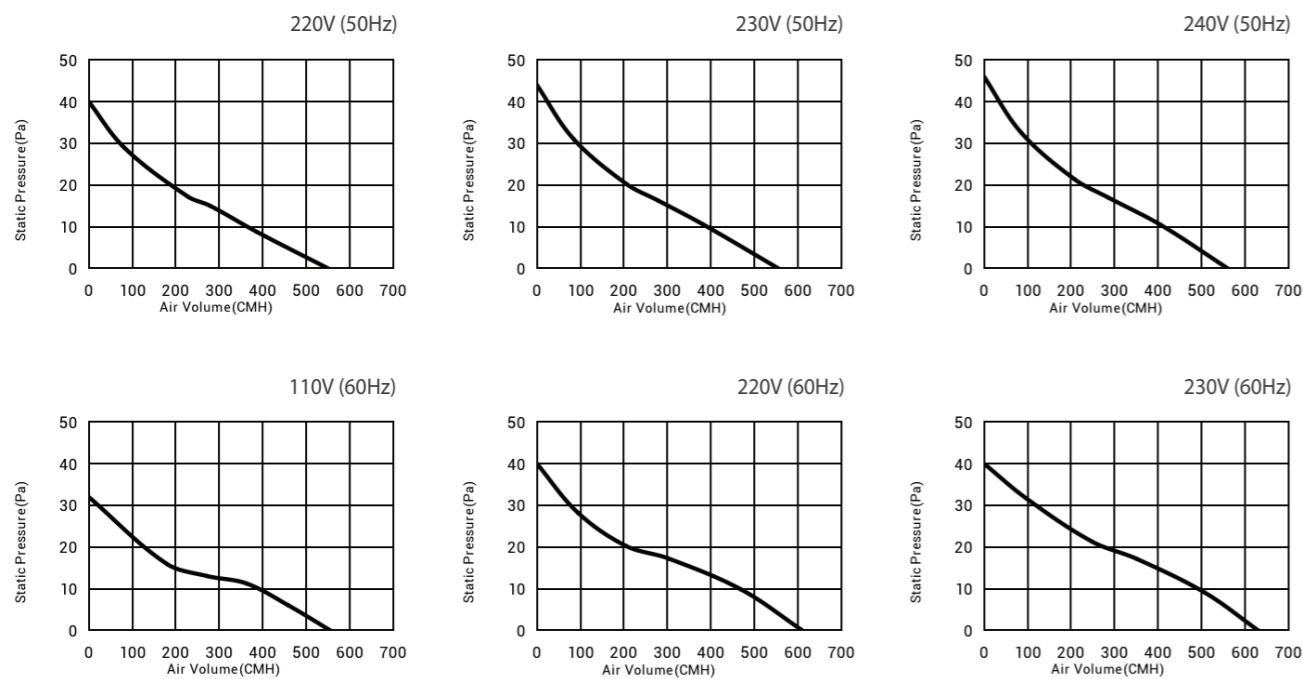

Wall Mount Type Ventilation Fan

Automatic Shutter Louver Series: 25ALA

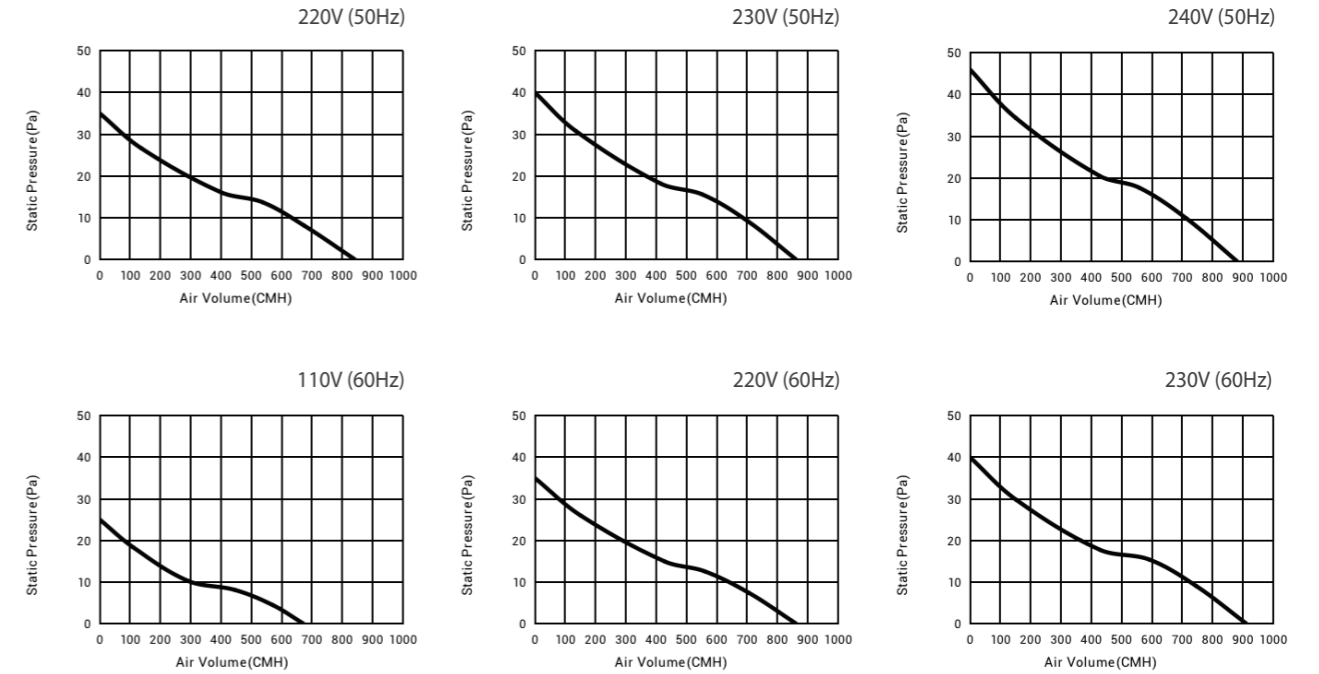

Automatic Shutter Louver Series: 30ALA

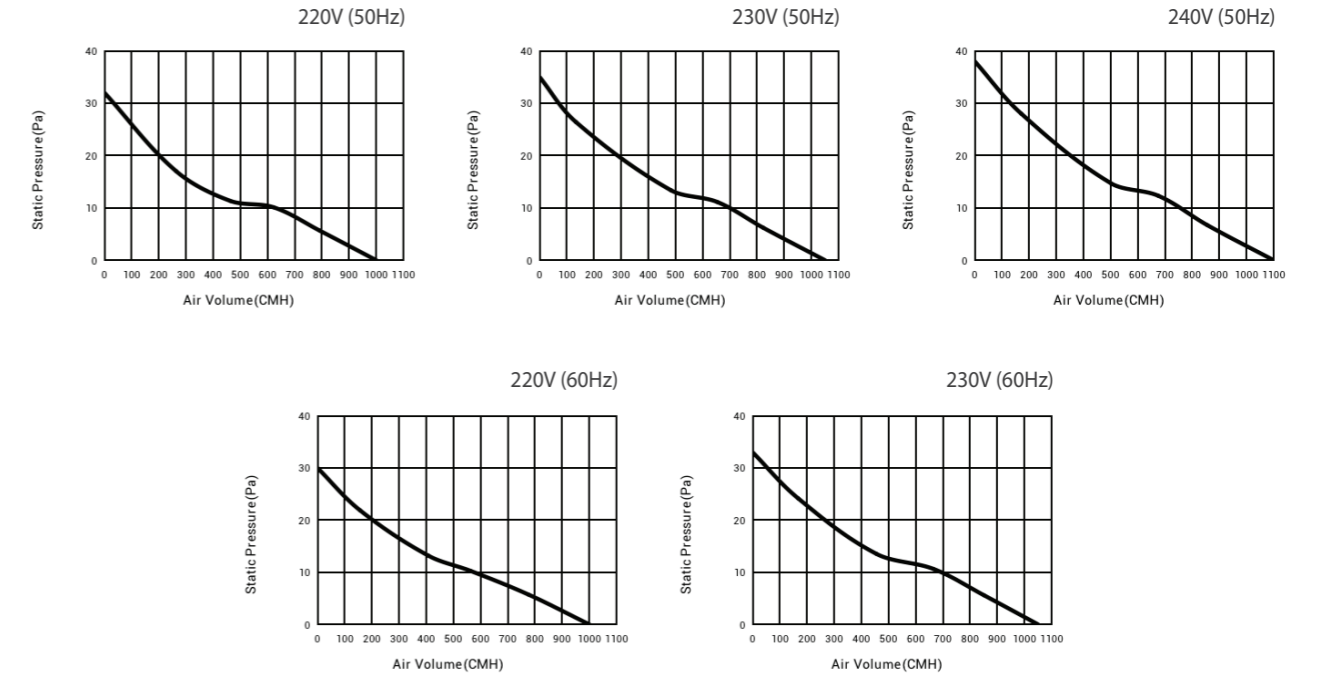

Performance Data Summary

Window Mount Type Ventilation Fan

Electric Shutter Series: 15WHCT

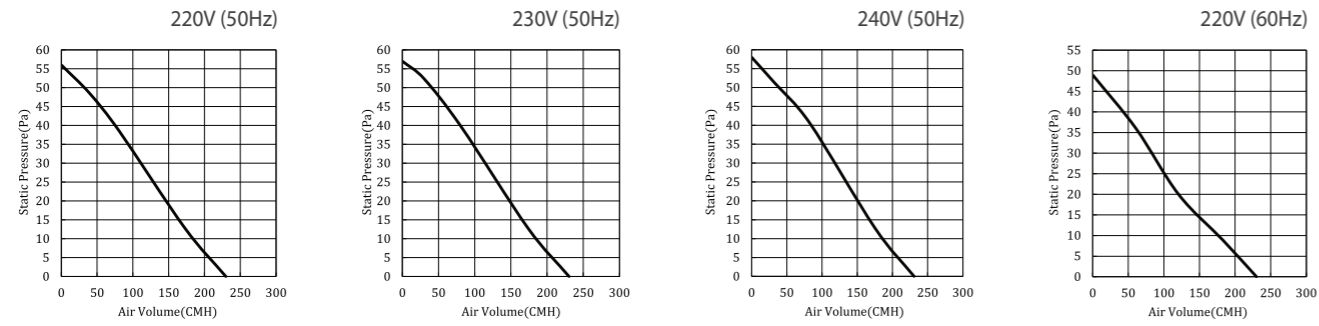

Electric Shutter Series: 20WHCT

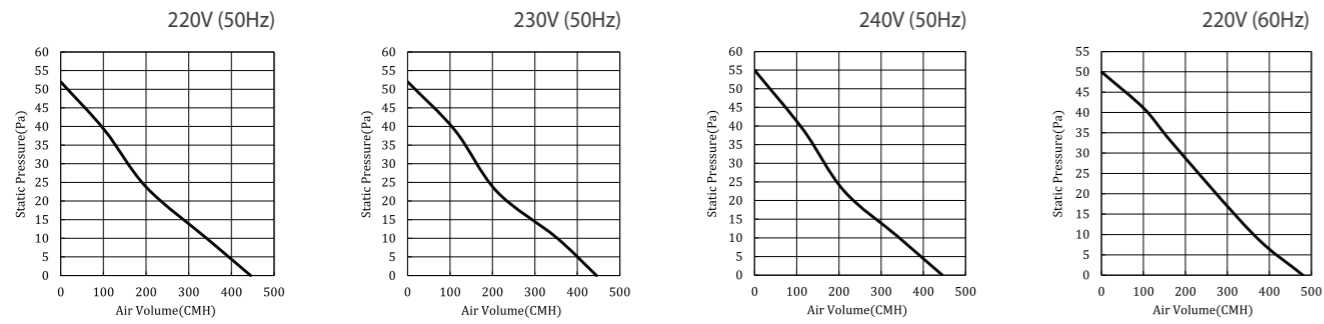

Automatic Shutter Series: 15WAA

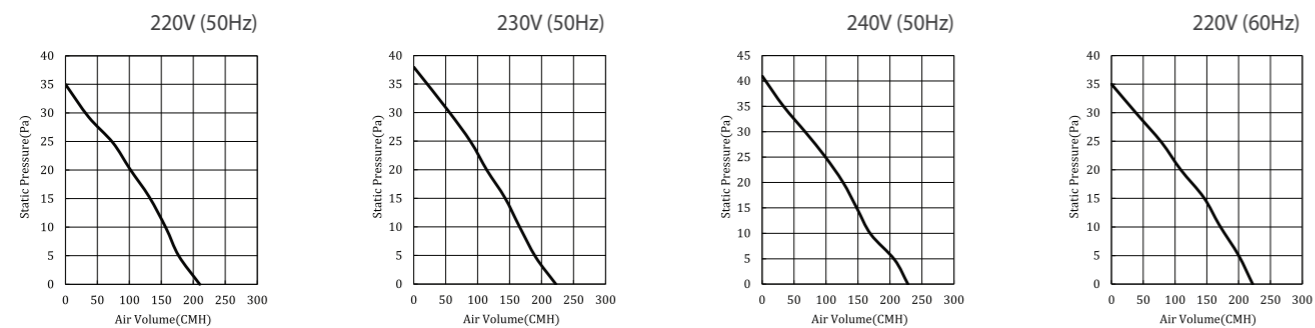

Window Mount Type Ventilation Fan

Automatic Shutter Series: 20WAA

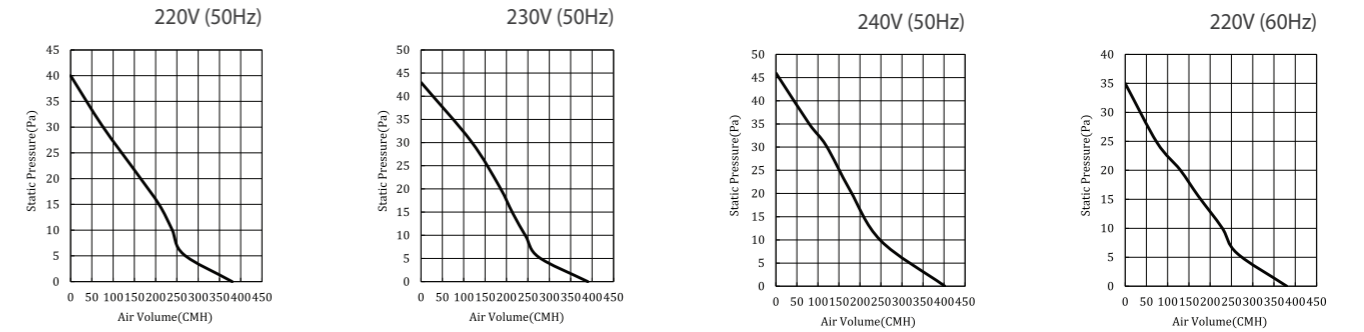

Automatic Shutter Series: 15WAAMN

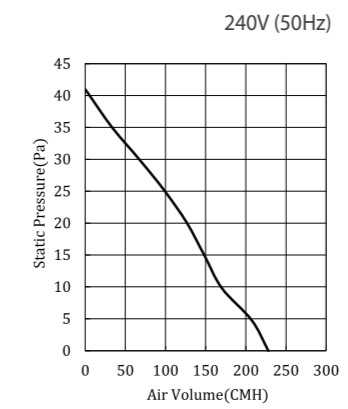

Automatic Shutter Series: 20WAAMN

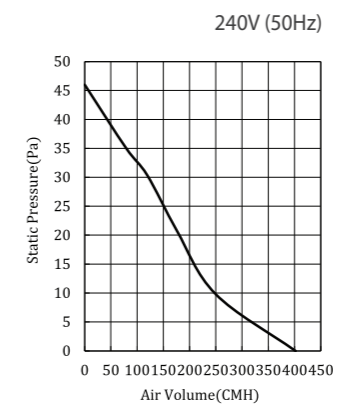

Performance Data Summary

Window Mount Type Ventilation Fan

Cord-operated Shutter Series: 15WUD

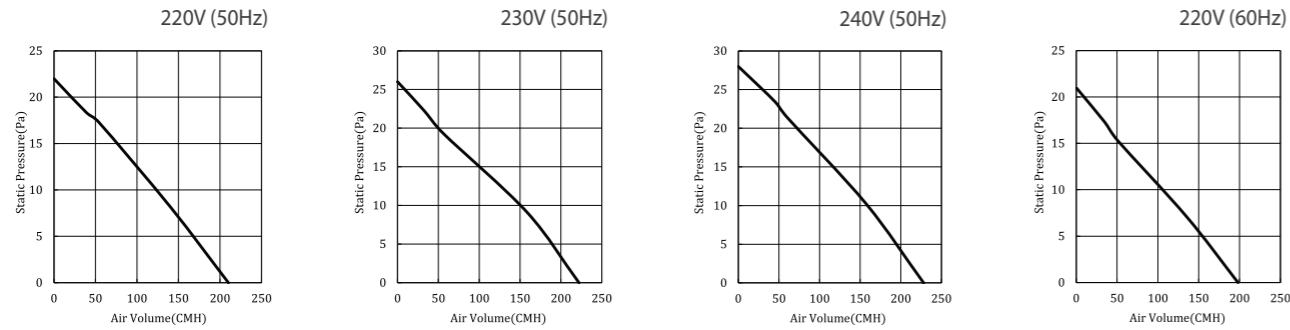

Cord-operated Shutter Series: 20WUD

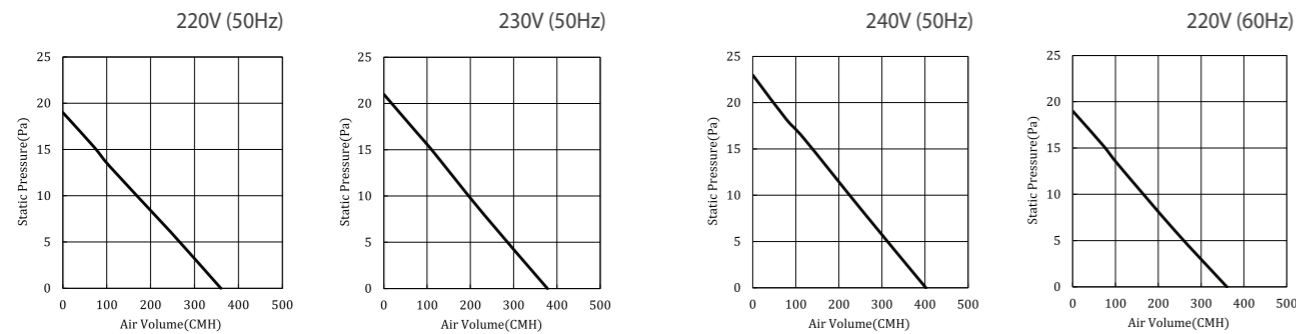

Cord-operated Shutter Series: 15WUDMN

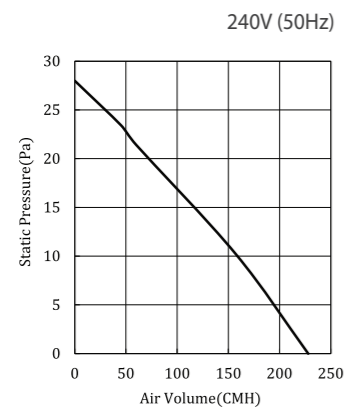

Cord-operated Shutter Series: 20WUDMN

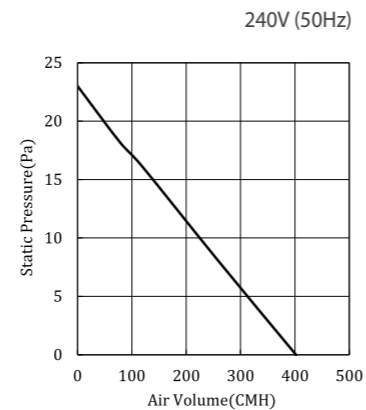

Industrial Type Ventilation Fan

Shutter Series: 40KAQA

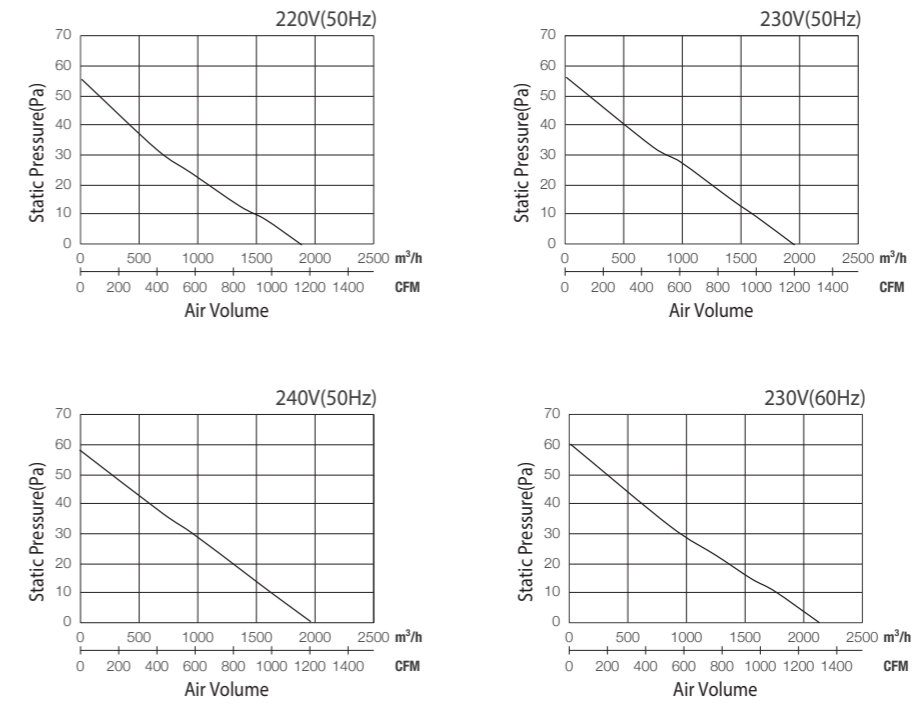

High Pressure Series: 25GSE

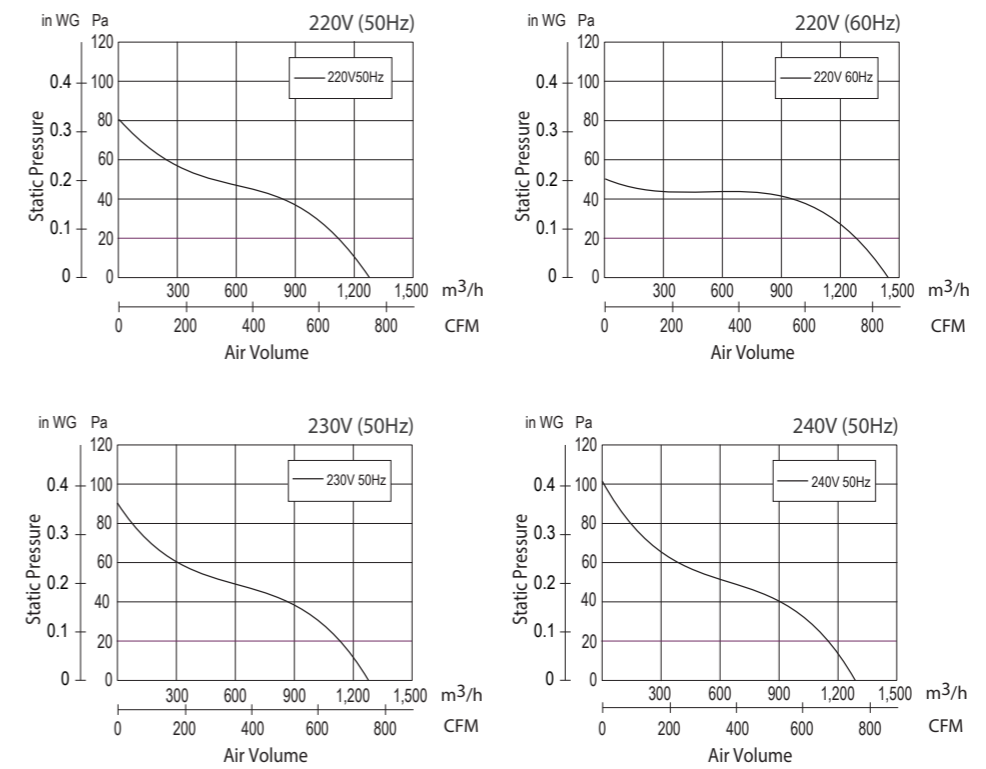

Performance Data Summary

Industrial Type Ventilation Fan

High Pressure Series: 30GSE

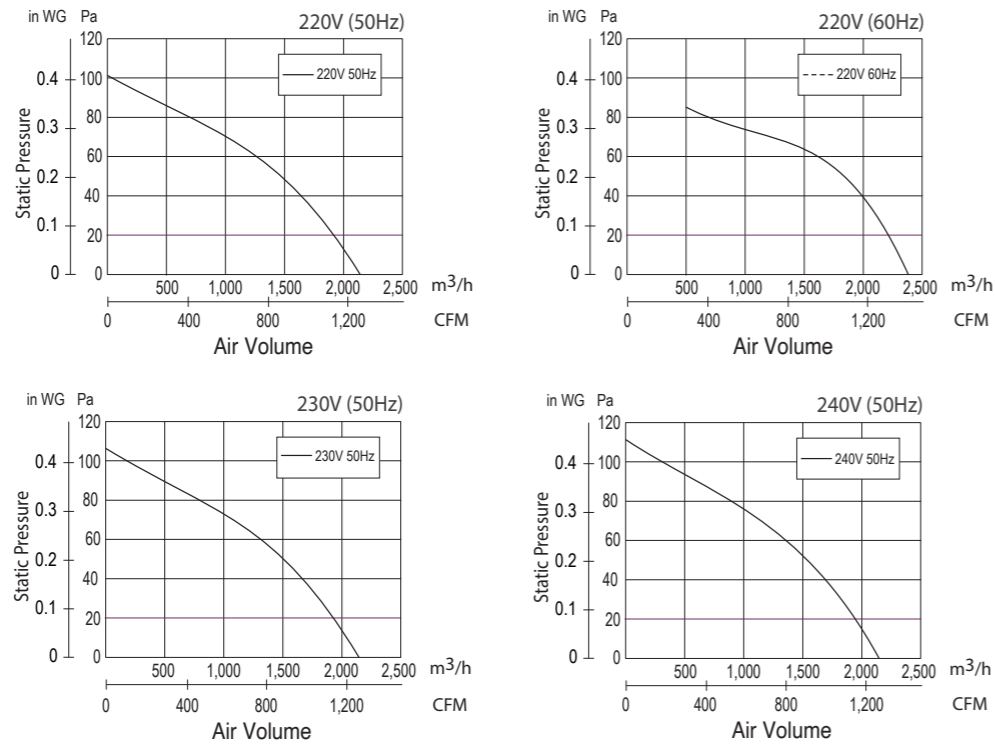

High Pressure Series: 35GSE

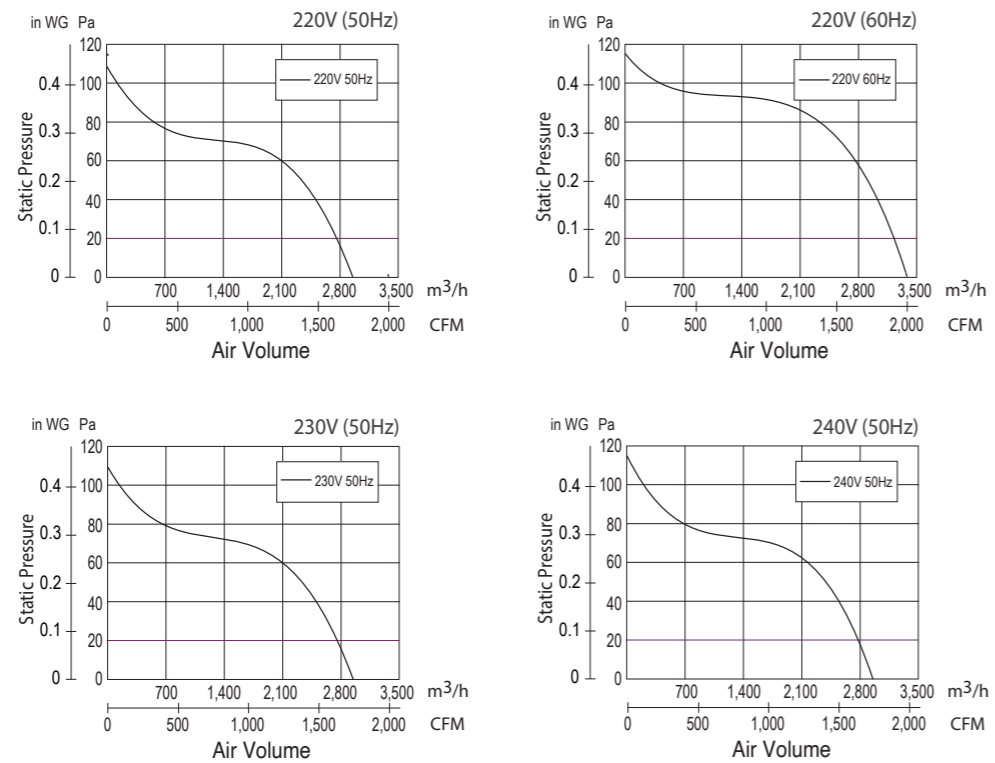

Industrial Type Ventilation Fan

High Pressure Series: 40GSE

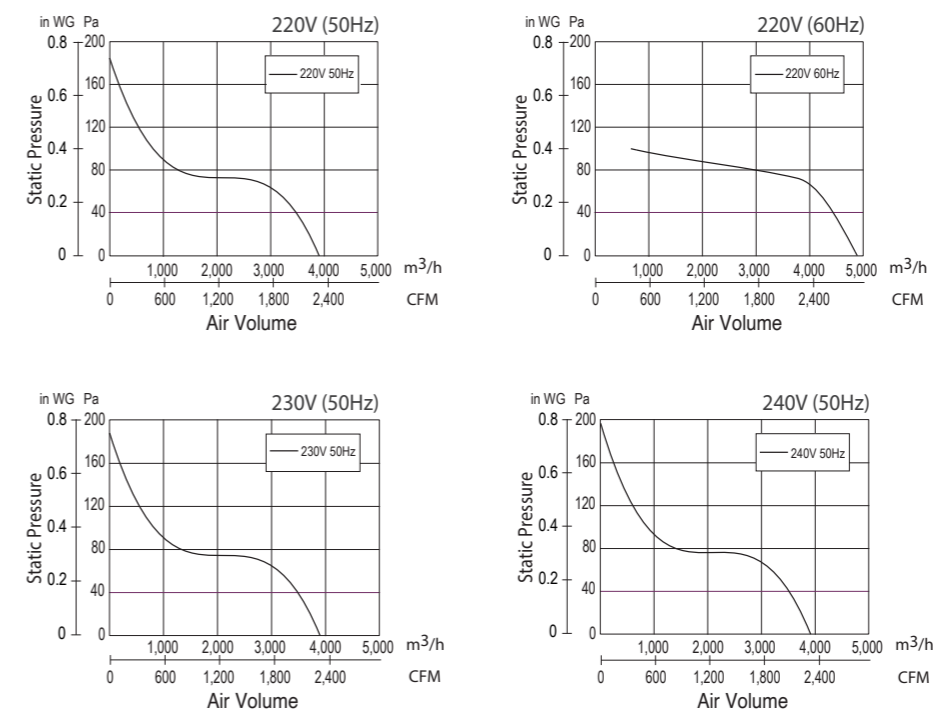

High Pressure Series: 45GSC

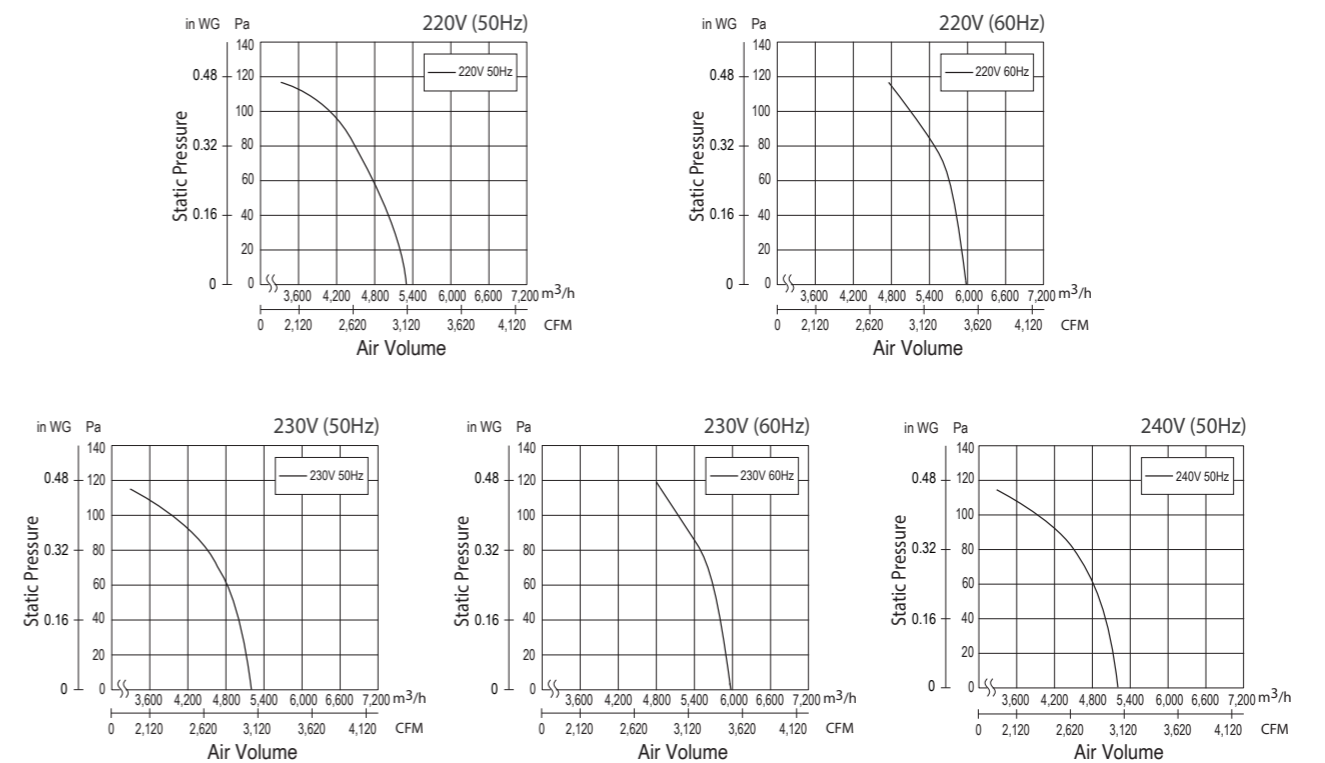

Performance Data Summary

Industrial Type Ventilation Fan

High Pressure Series: 50GSC

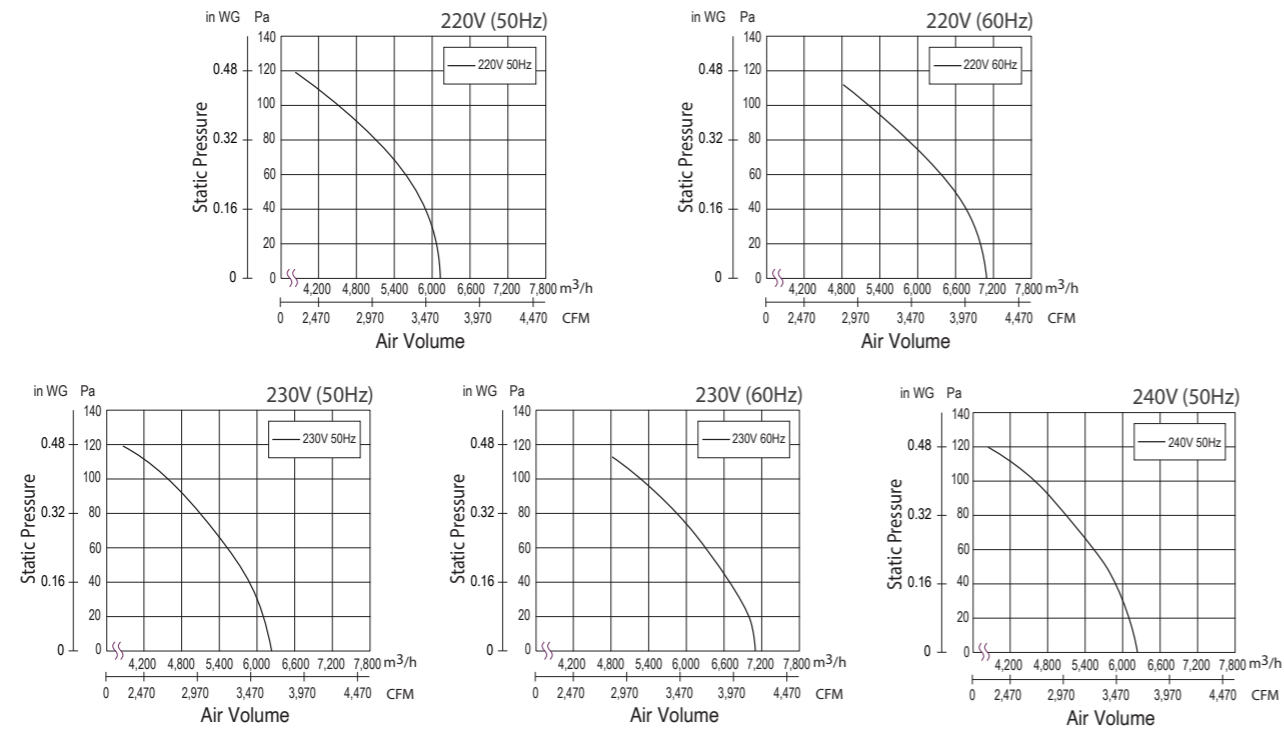

High Pressure Series: 60GSC

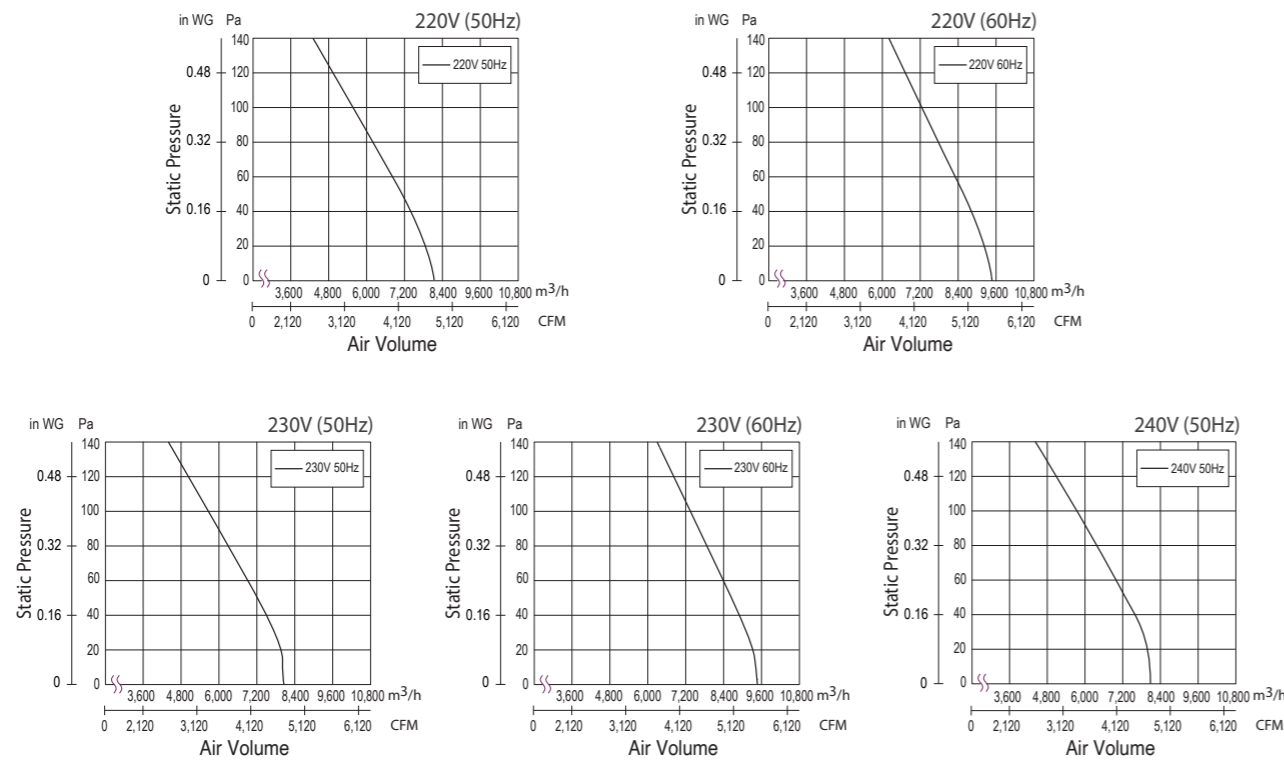

Industrial Type Ventilation Fan

High Pressure Series: 45GTC

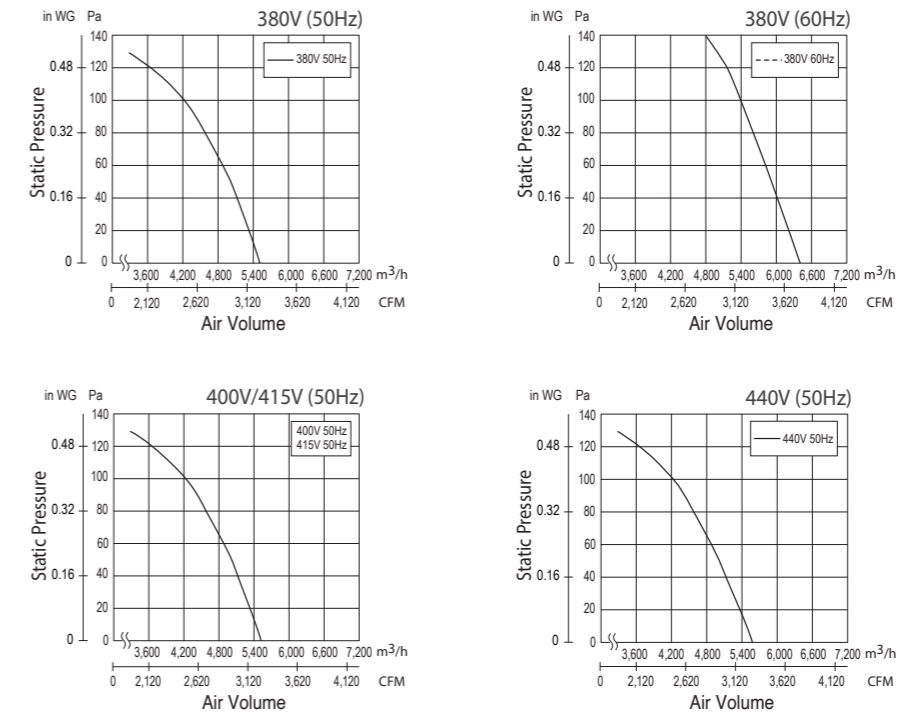

High Pressure Series: 50GTC

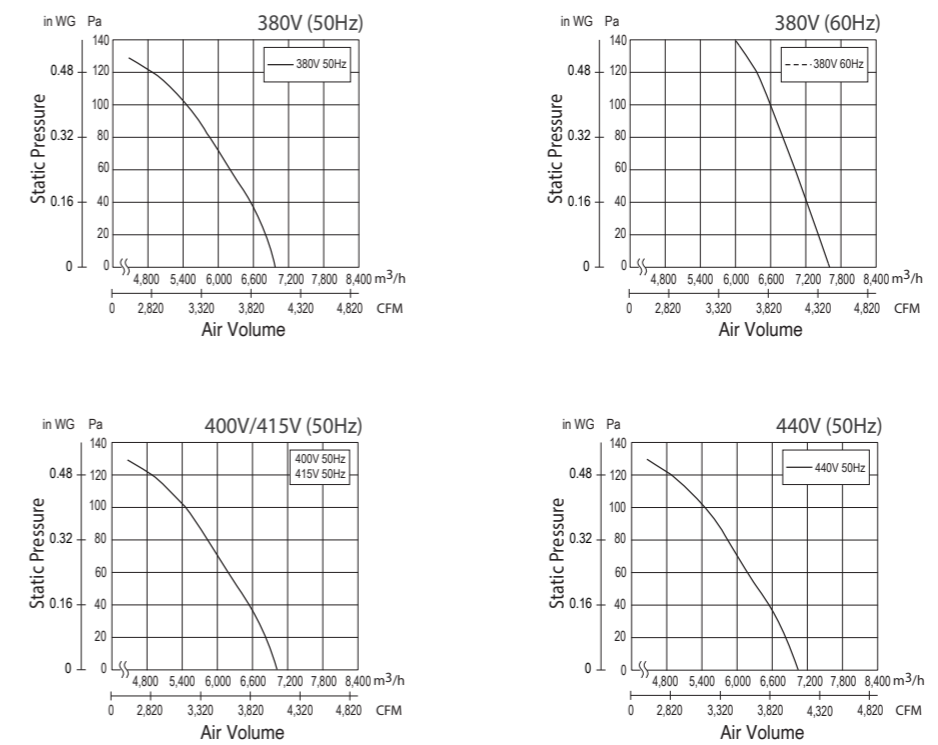

Performance Data Summary

Industrial Type Ventilation Fan

High Pressure Series: 60GTC

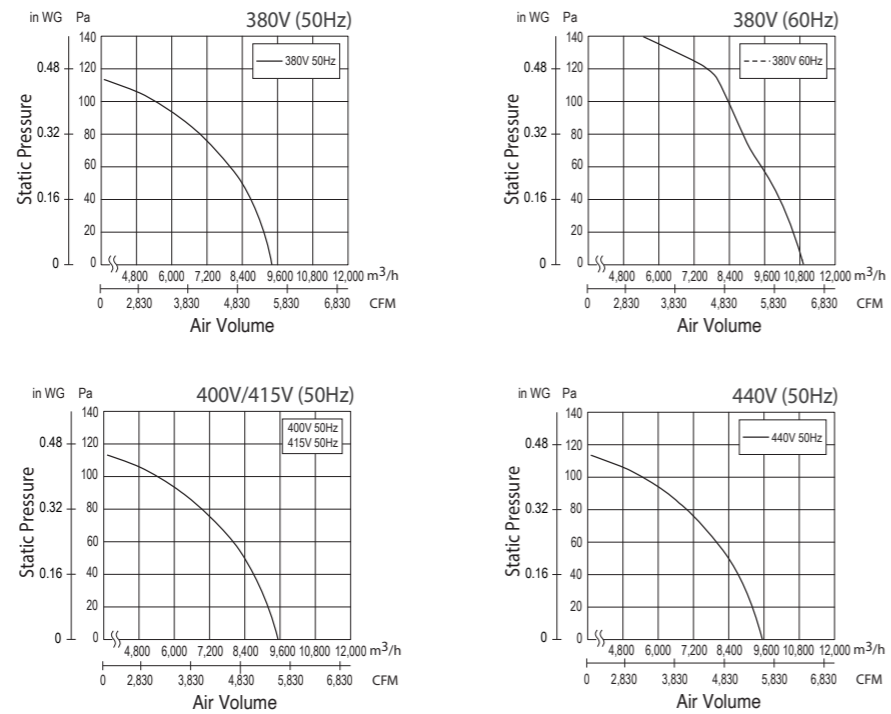

Cabinet Fan (In-line Fan)

Standard Series: 12NSB

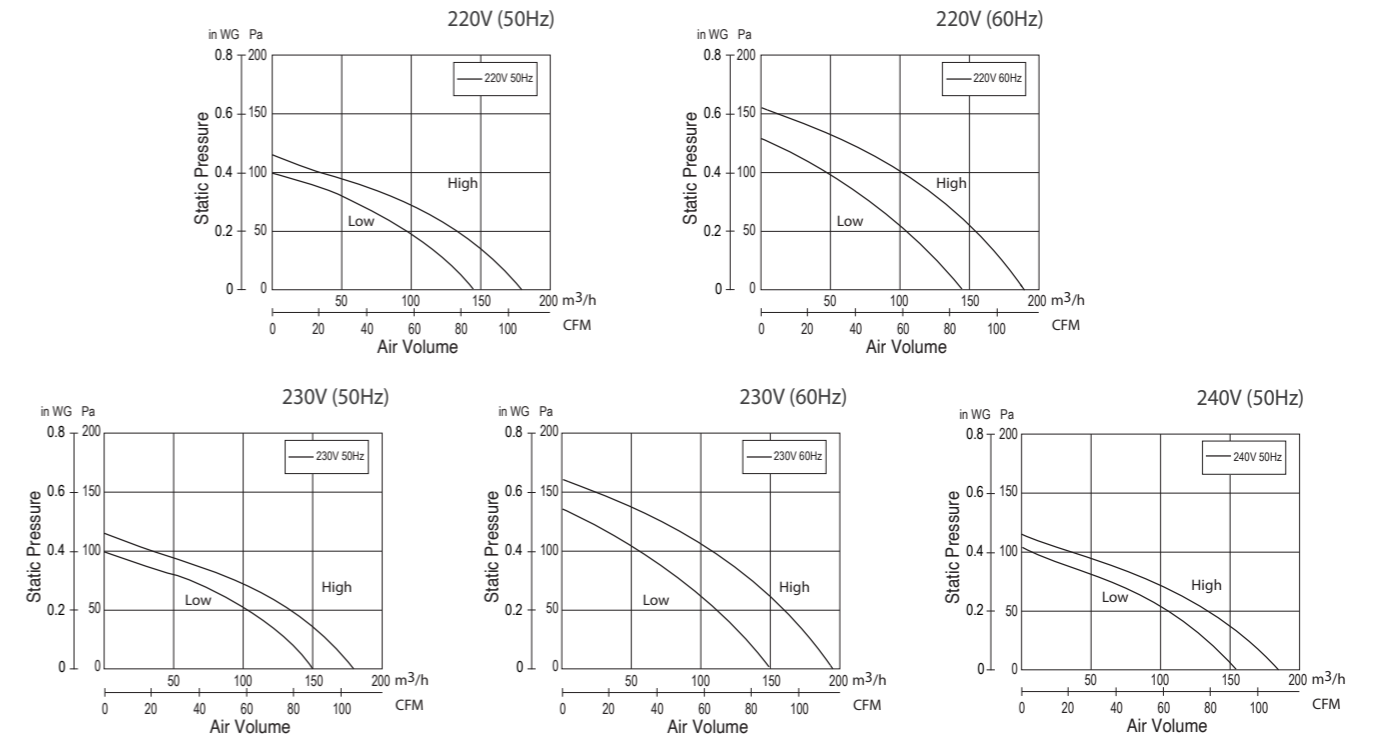

Standard Series: 15NSB

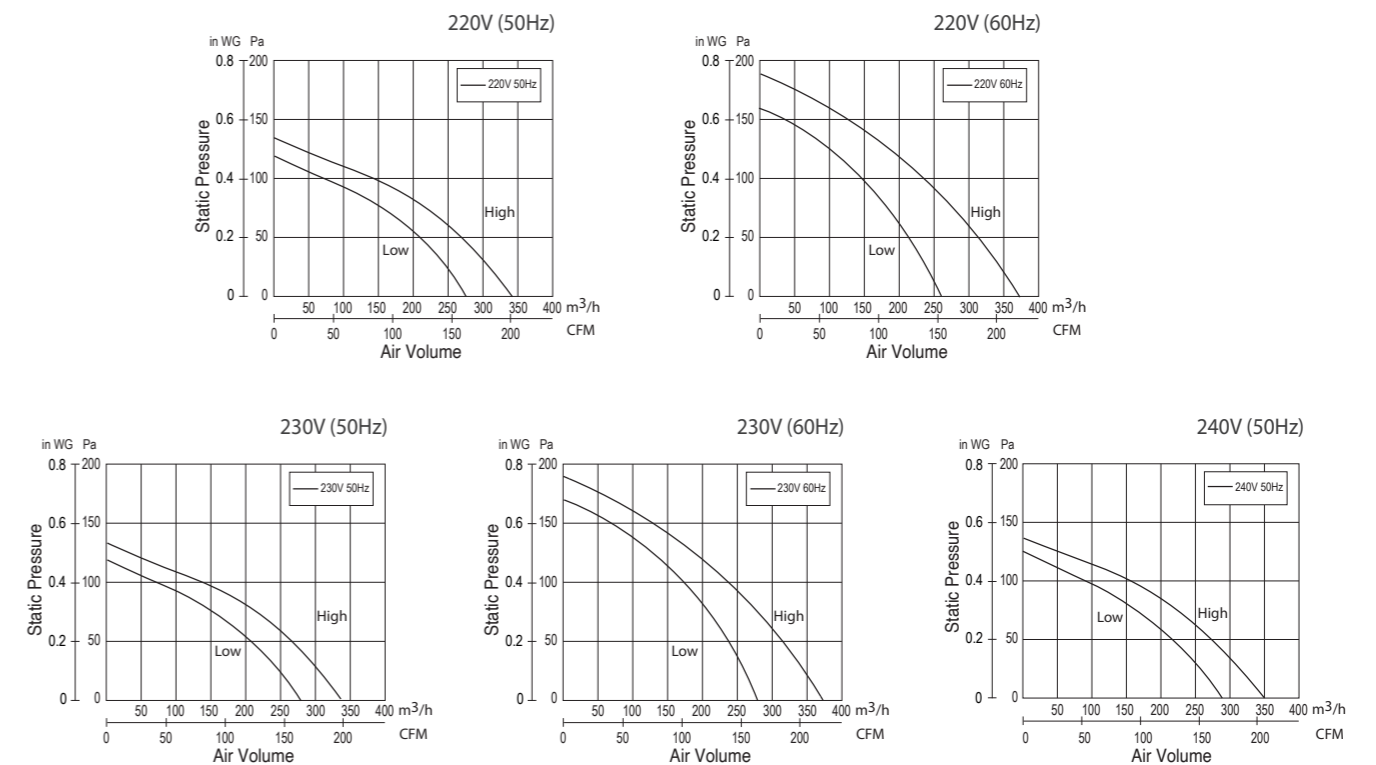

Performance Data Summary

Cabinet Fan (In-line Fan)

Standard Series: 18NSB

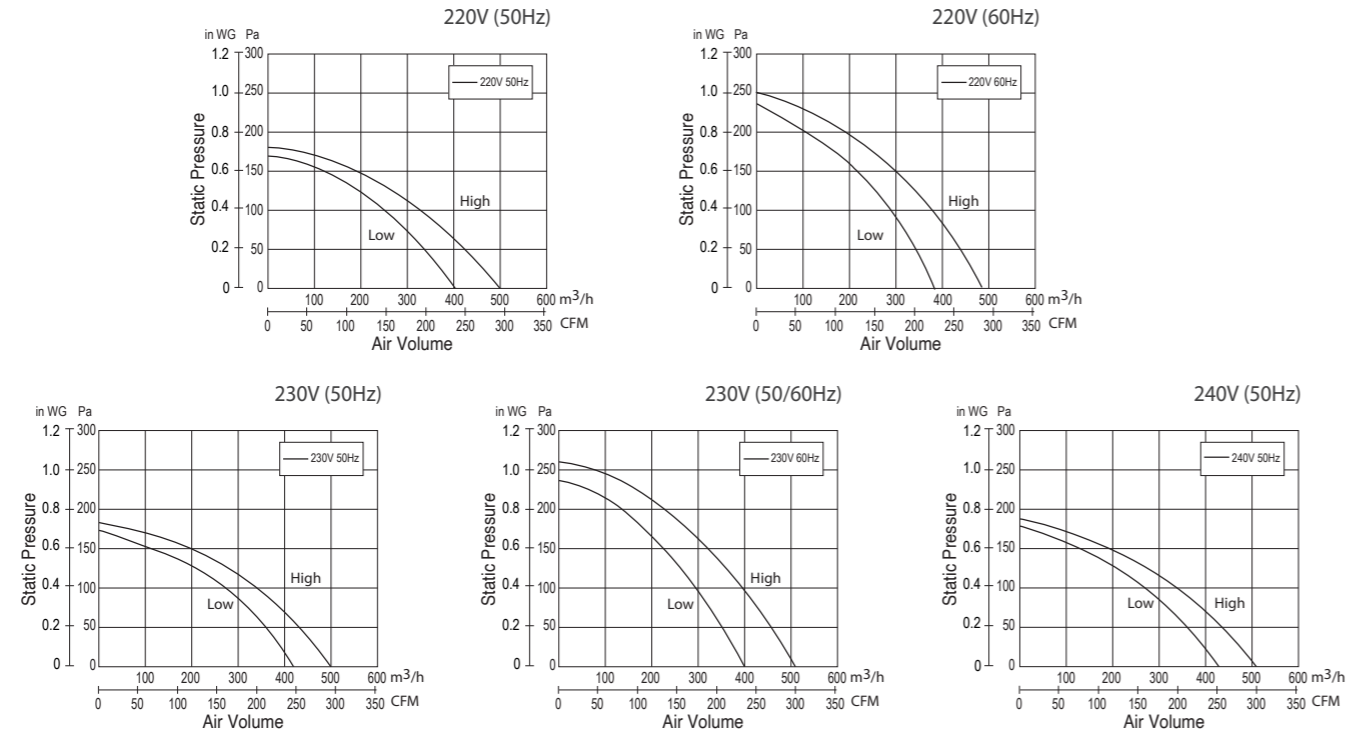

Standard Series: 18NFB

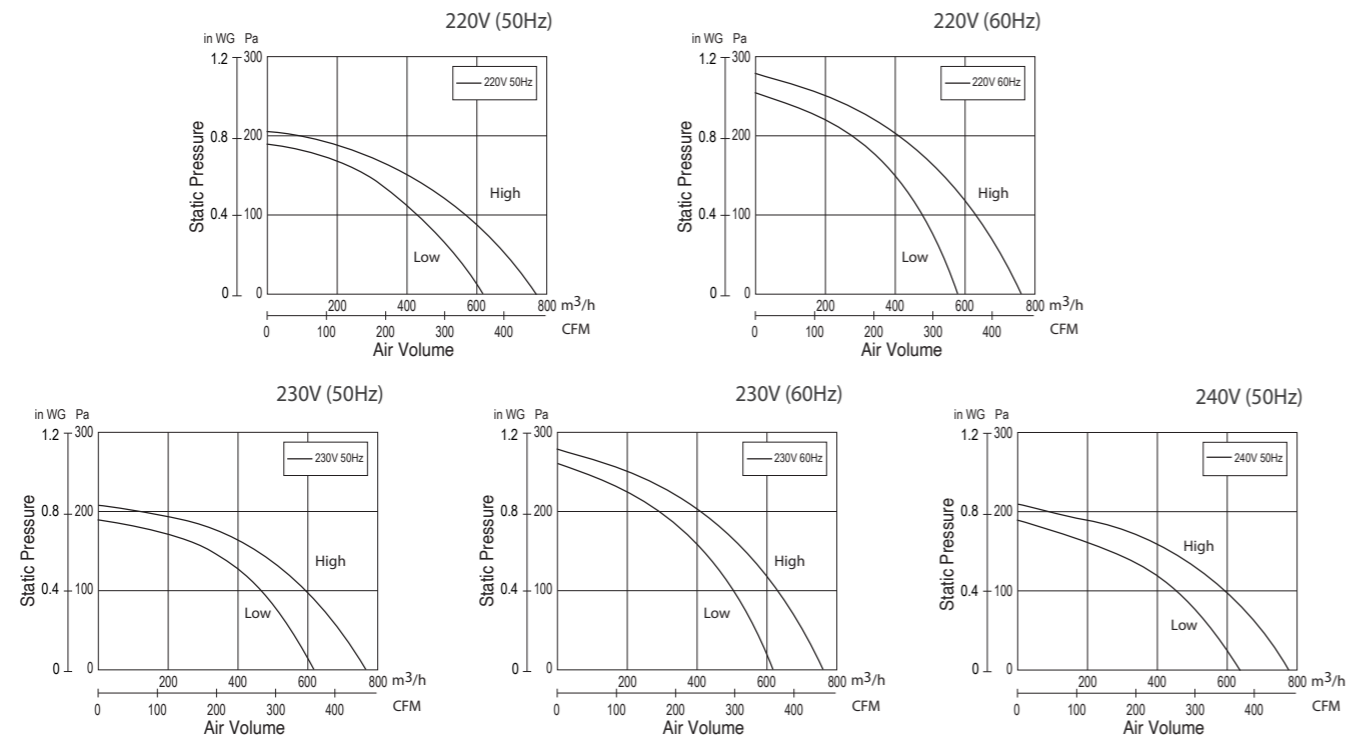

Cabinet Fan (In-line Fan)

Standard Series: 20NSB

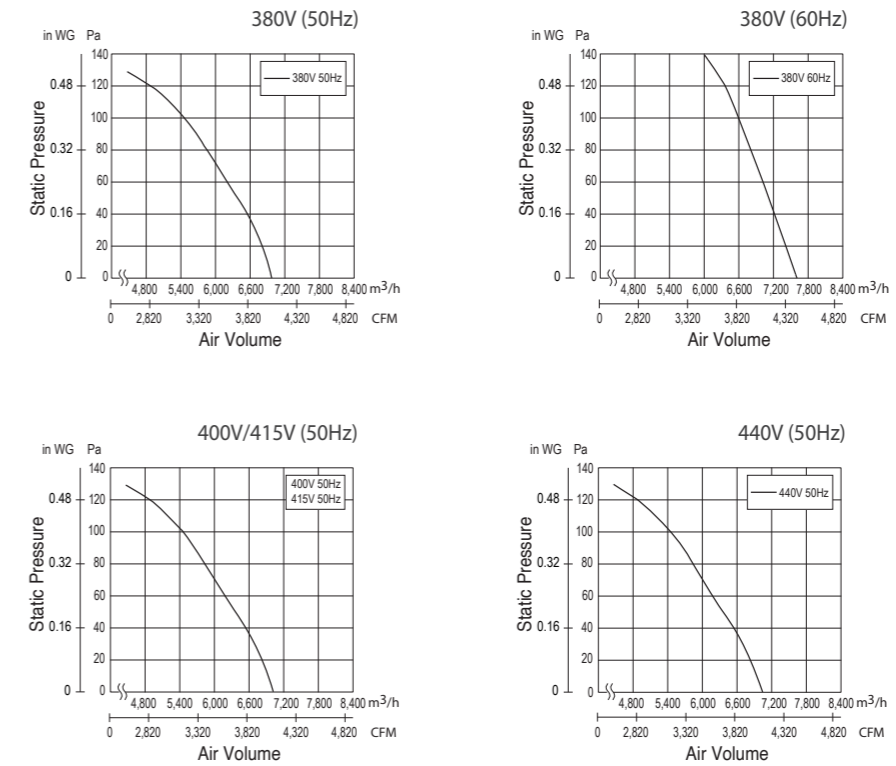

Standard Series: 23NLB

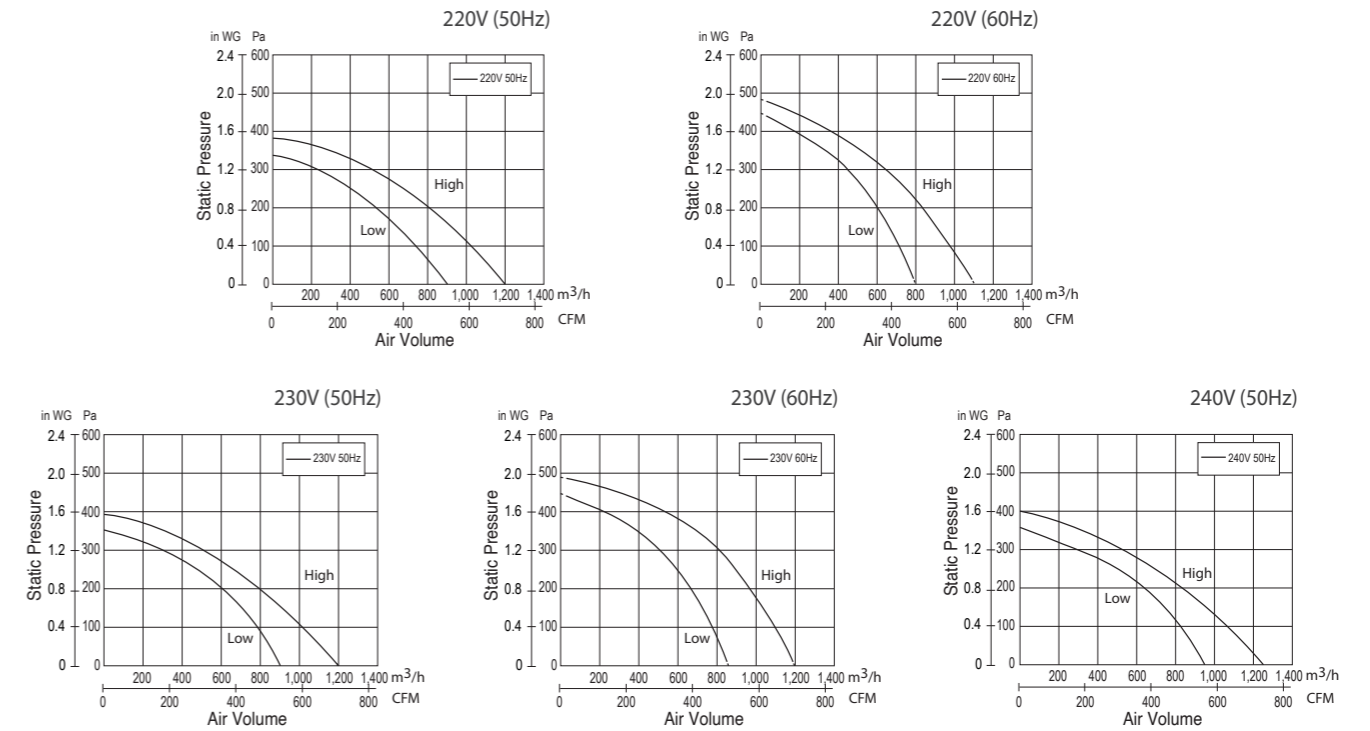

Performance Data Summary

Cabinet Fan (In-line Fan)

Three Phase Series: 25SWC

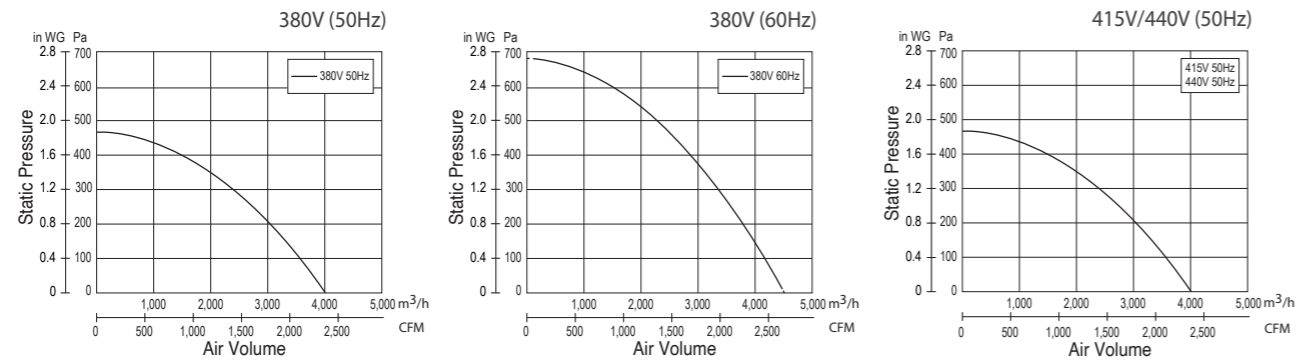

Three Phase Series: 25SMC

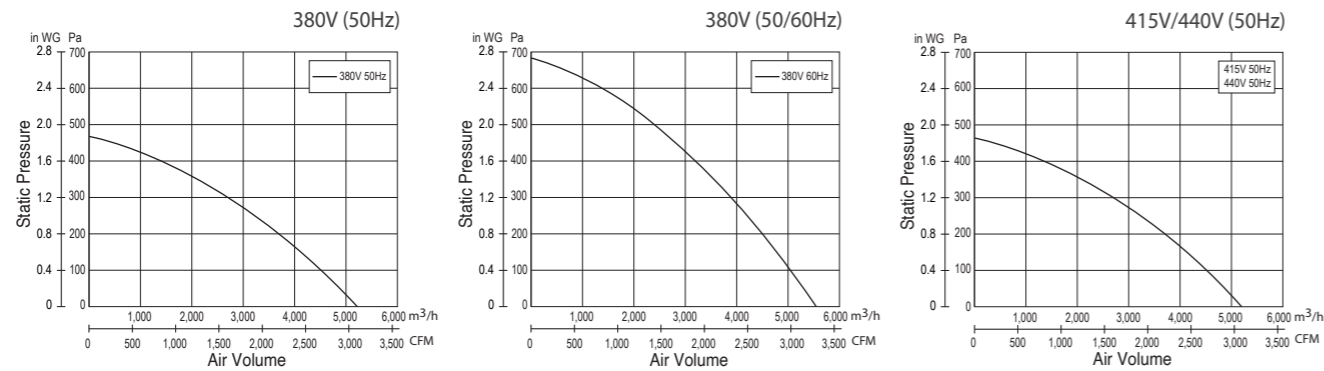

Three Phase Series: 28NXC

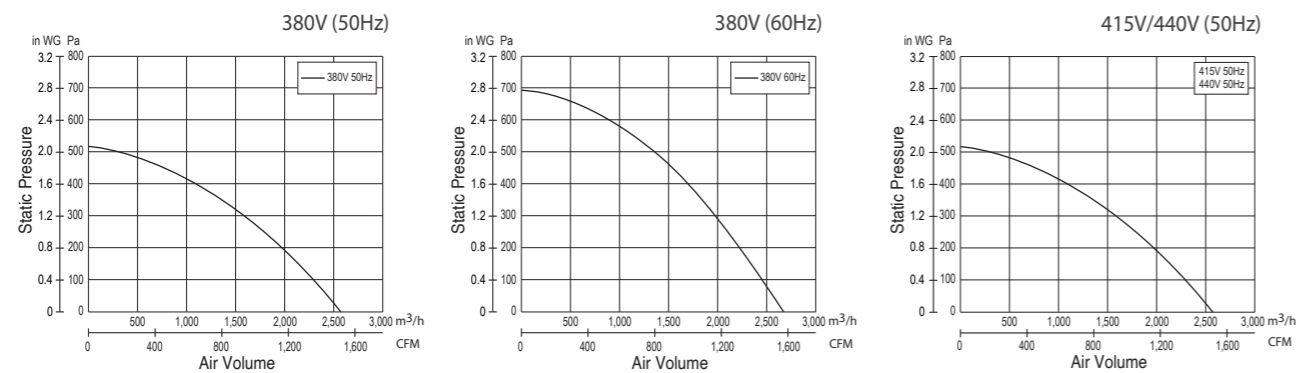

Mini Sirocco Fan

10CGB

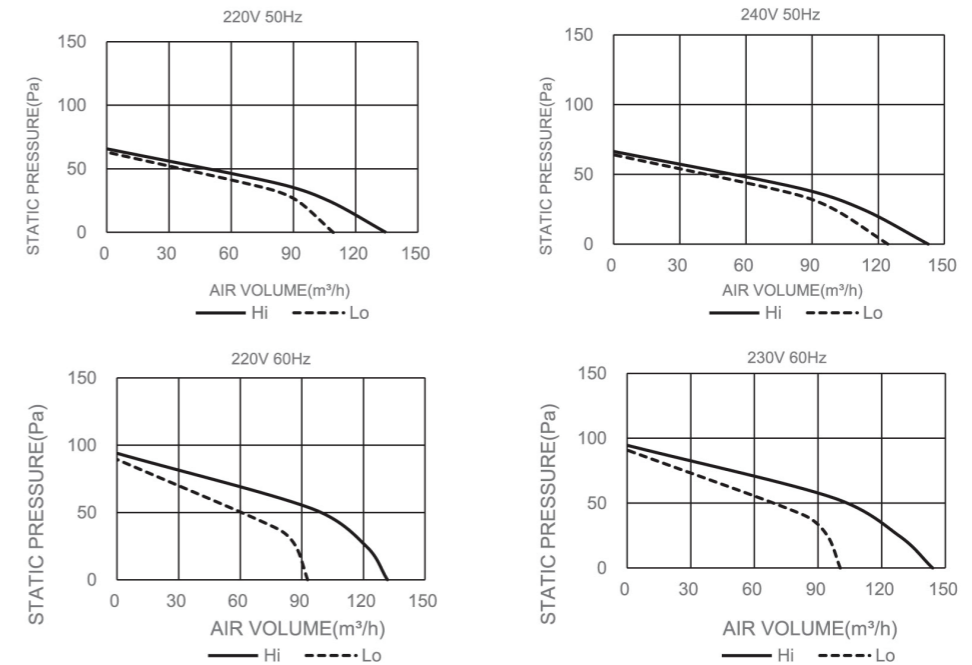

12CGB

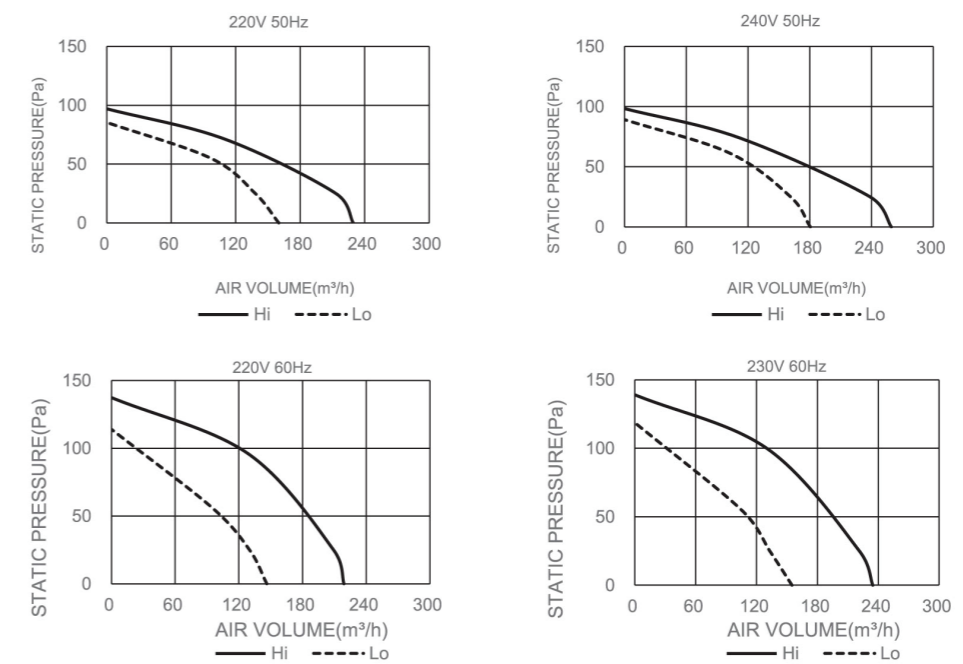

Performance Data Summary

Mini Sirocco Fan

14CGB

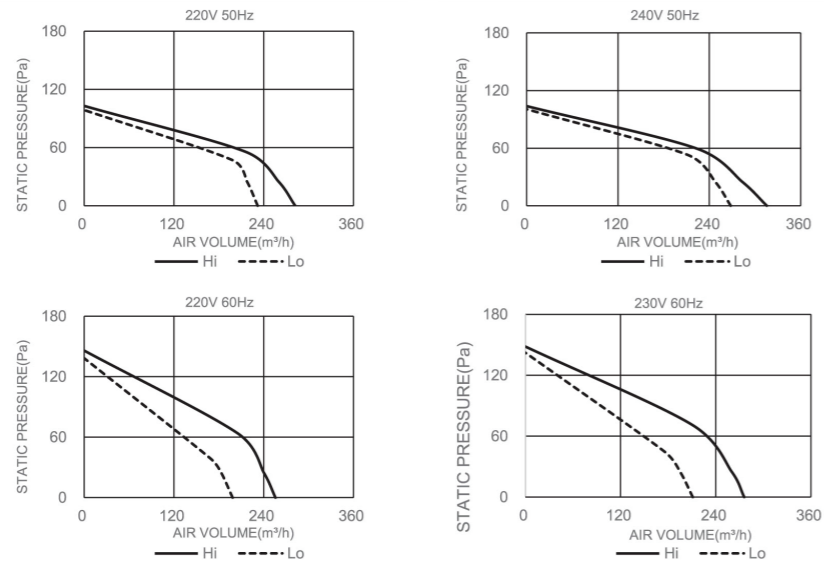

16CGB

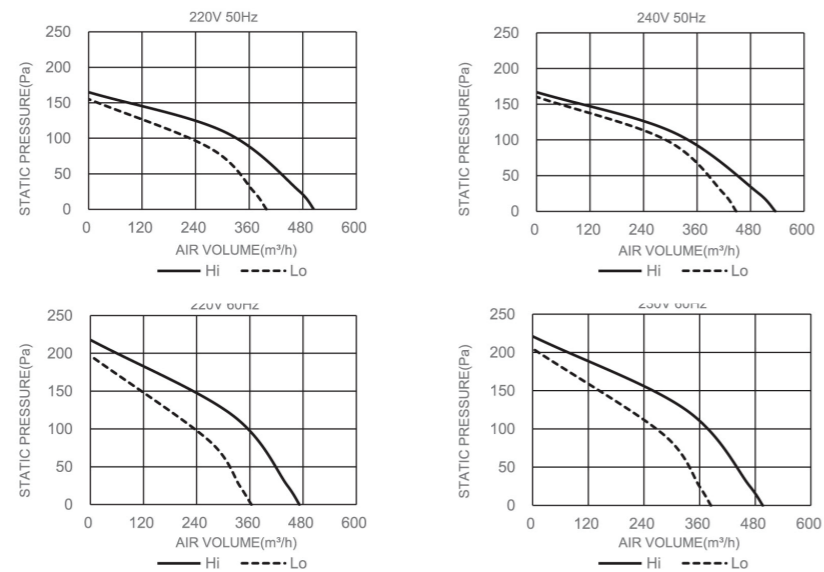

17CGB

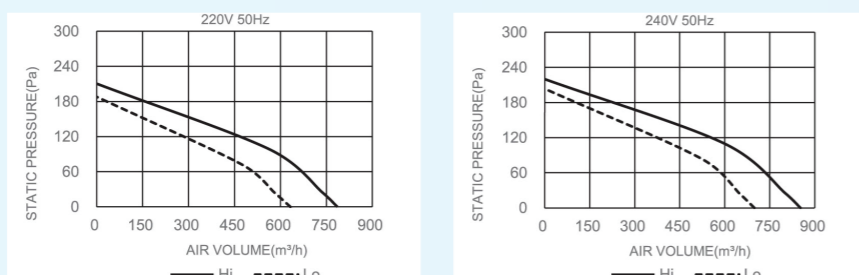

Mini Sirocco Fan

19CGB

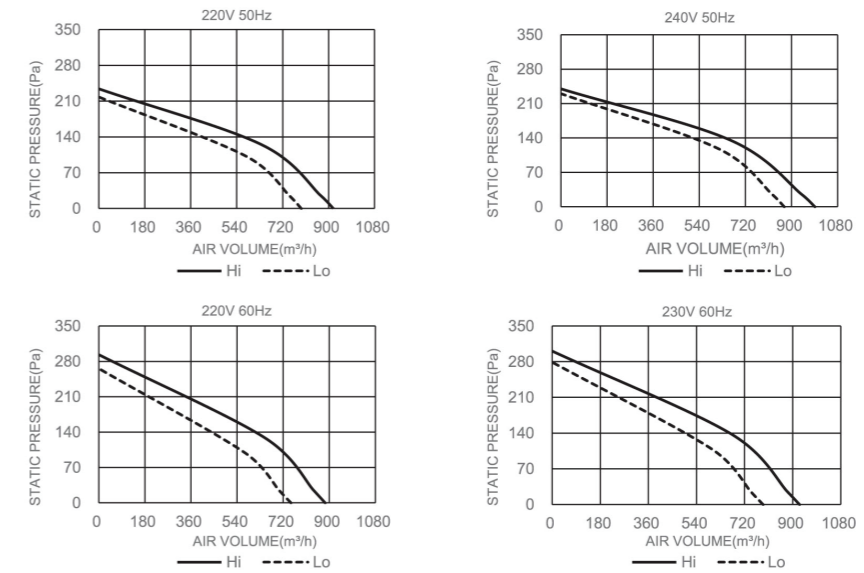

21CGB

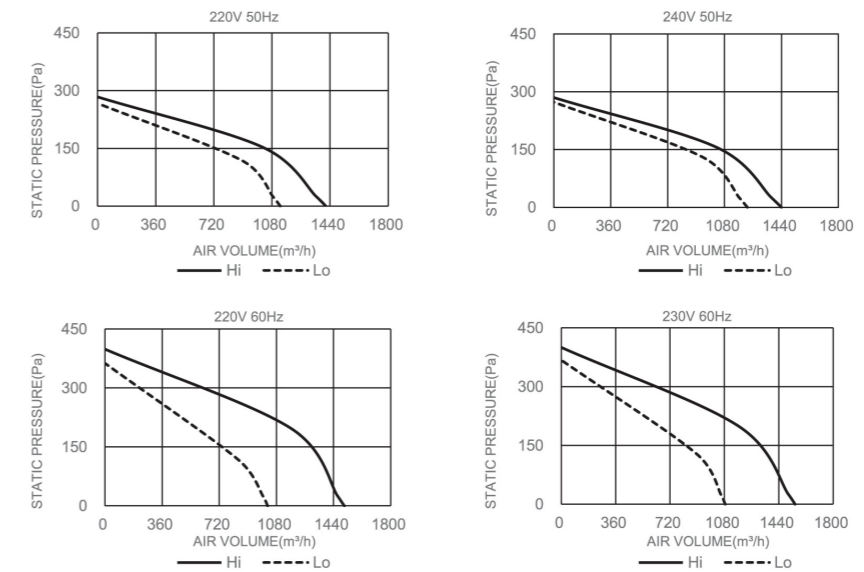

17CGB

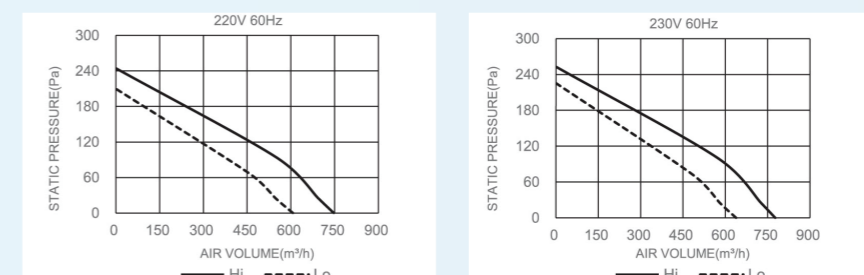

Performance Data Summary

Energy Recovery Ventilator

Standard Series:
E25DZUA

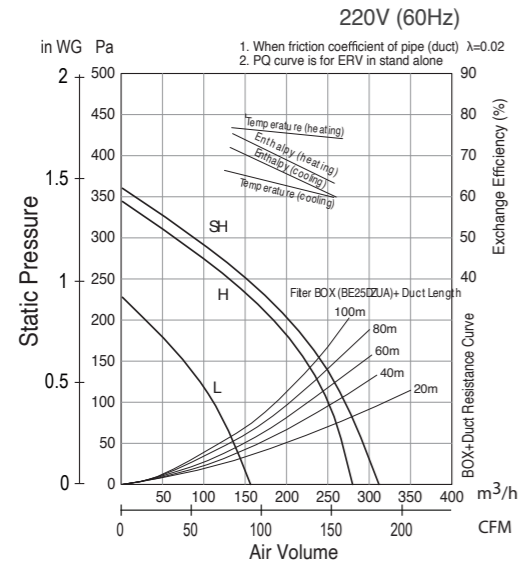

Standard Series:
E35DZUA

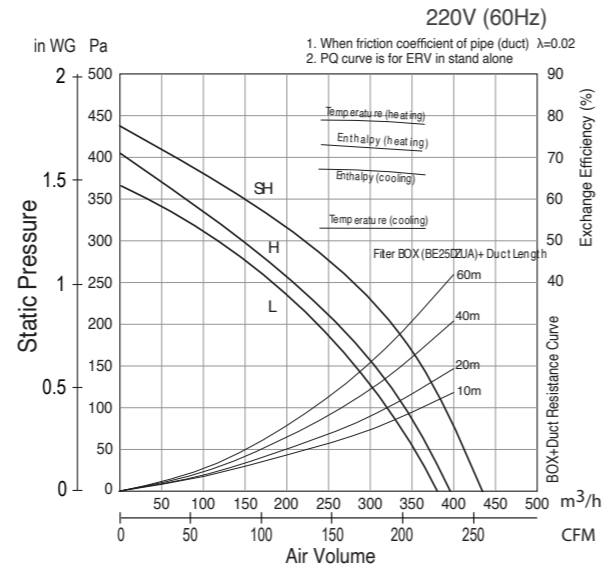

Standard Series:
E50DZUA

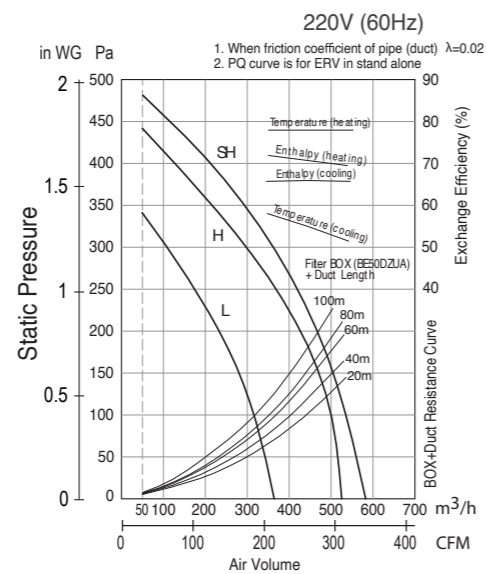

Thermo Ventilator

Ceiling Mount Series: 30BUC

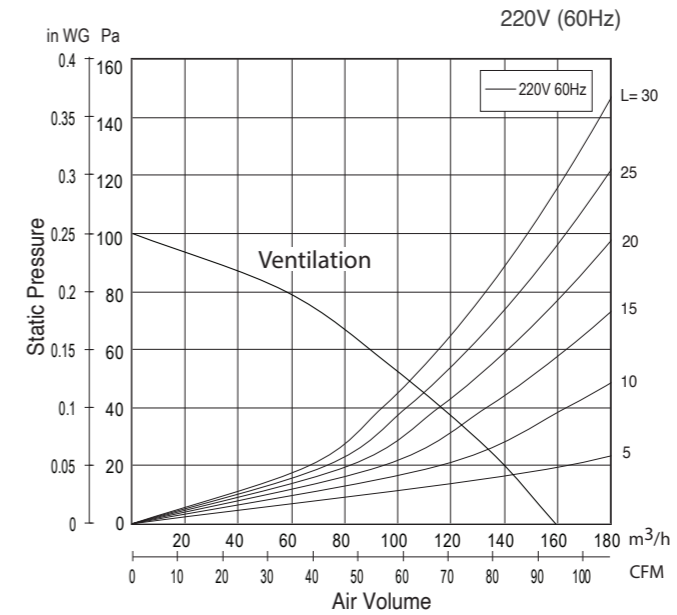

Range Hood

Twin Motor Series: 90HQUA

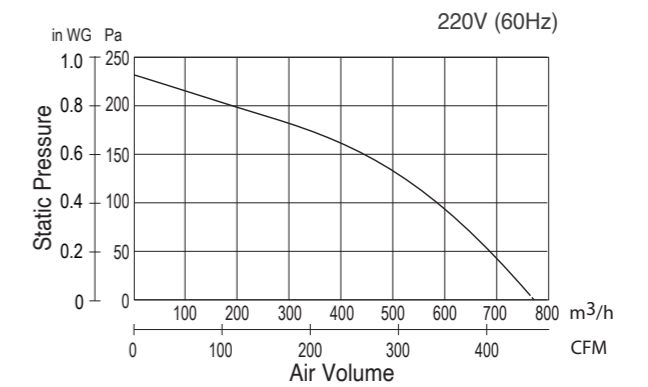
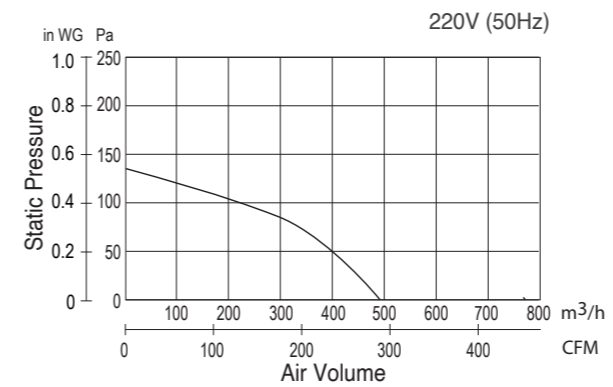

Performance Data Summary

Accessories - Pipe Hood

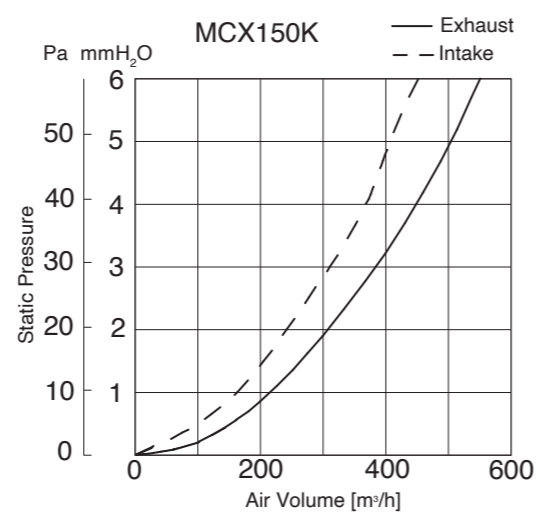
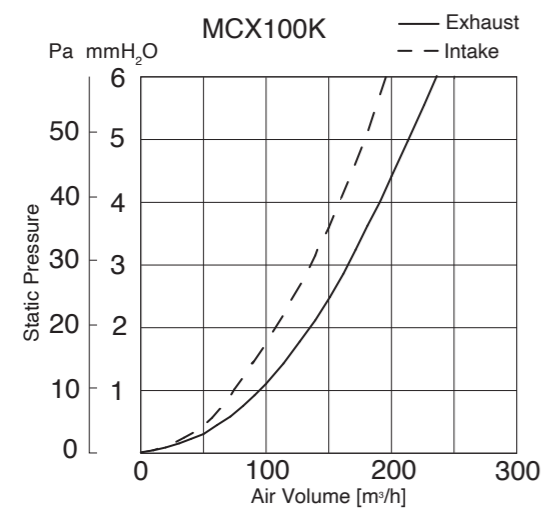
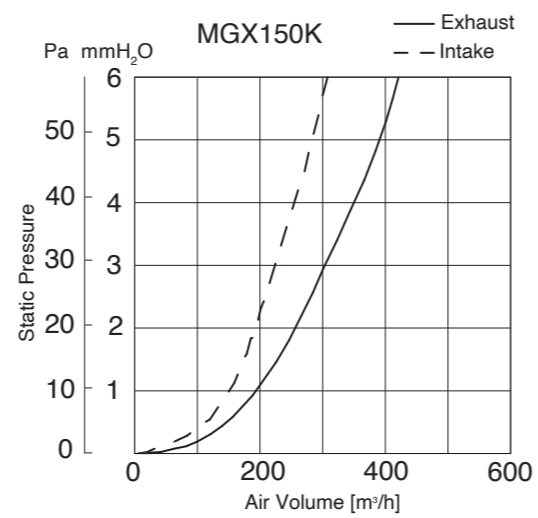
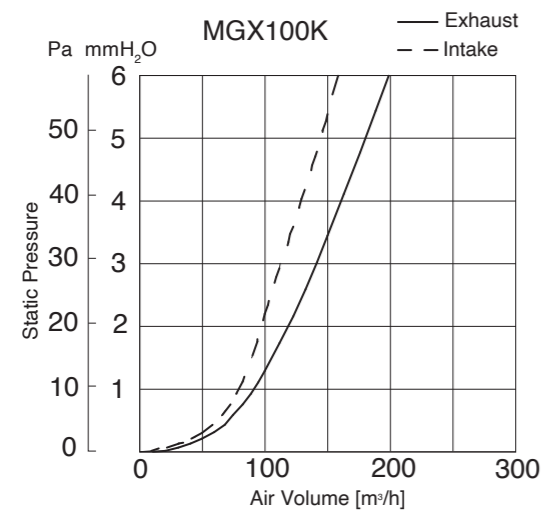

Accessories - Vent Cap

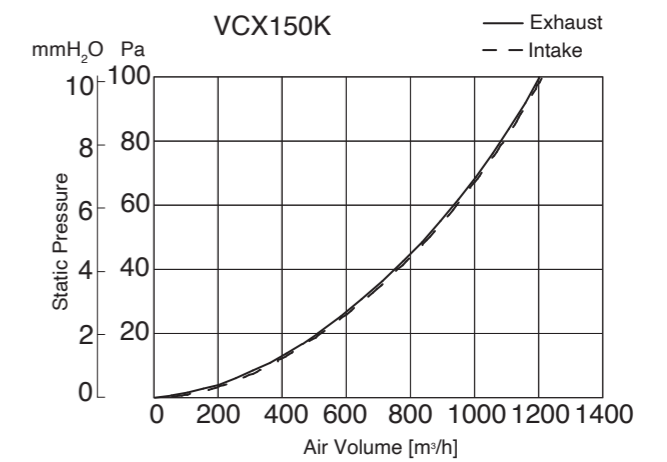
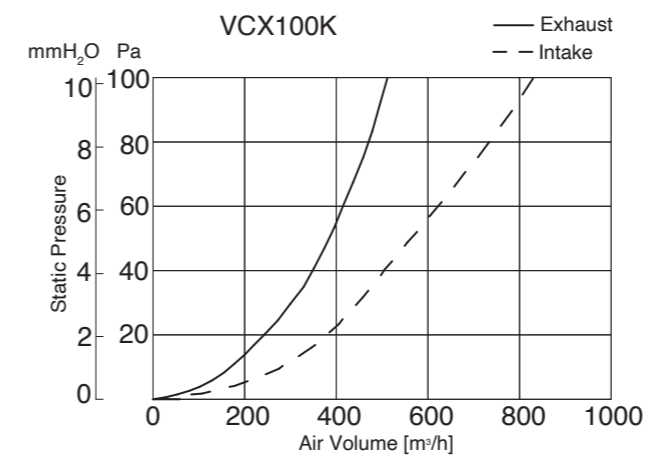
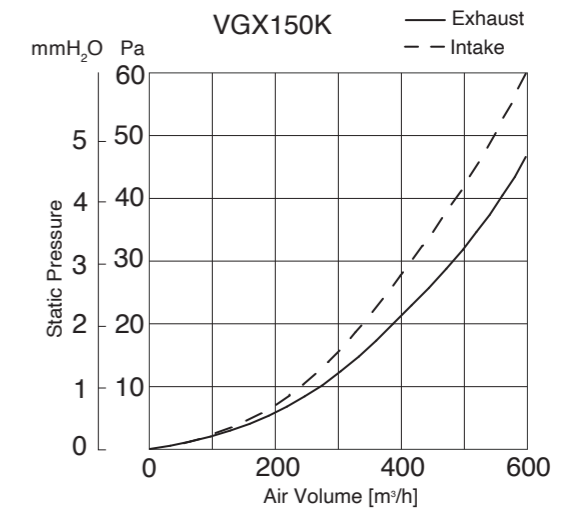
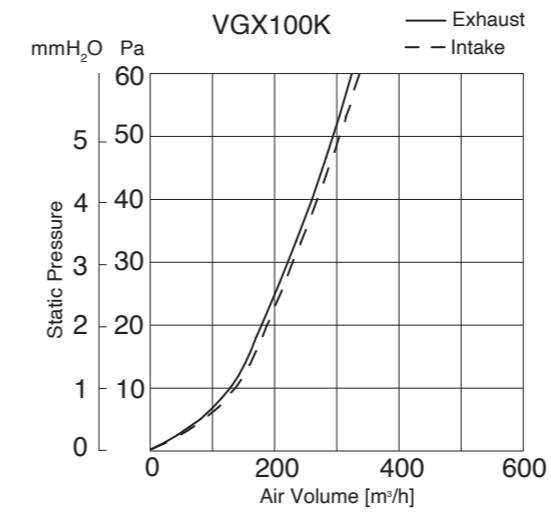

Reference Project

SAUDI ARABIA

Luxury Villas
1600 Villa - Sheik Zayed housing program- Phase 1-3
Window & Wall Mount Ventilation Fan, Sirocco Fan

SUDAN

Commercial Residential Building
Energy Recovery Ventilator

UAE

Residential Villas
519 villas
Window Mount Type Ventilation Fan

UAE

Luxury Villas
200 villas
Ducted Ventilation Products

UAE

Commercial Building
Window Mount Type Ventilation Fan

SAUDI ARABIA

Residential Villas
Local Housing Development
for Locals
Ducted Ventilation Products

QATAR

Residential Villas
42 Villas
Window Mount Type Ventilation Fan

UAE

Residential Building
Labor Camps Complexes
Ceiling Fan, Window Mount &
Industrial Type Ventilation Fan

Reference Project

Installation Method

QATAR

Commercial Residential Building
Ceiling Fan, Wall Mount Louver
Type Ventilation Fan

QATAR

Residential Building
234 Apartments
Ceiling Mount Type Ventilation Fan

UAE

Residential Villas
220 Villas
Window & Wall Mount Type
Ventilation Fan

SAUDI ARABIA

Net Zero Energy Green House Model
Cabinet Fan, Wall Mount Louver Type
Ventilation Fan,
Energy Recovery Ventilator

- P.167 Ceiling Mount Type Ventilation Fan
- P.169 Wall Mount Type Ventilation Fan
- P.171 Window Mount Type Ventilation Fan
- P.173 Industrial Type Ventilation Fan
- P.174 Cabinet Fan
- P.176 Mini Sirocco Fan
- P.177 Energy Recovery Ventilator
- P.178 Thermo Ventilator
- P.179 Range Hood
- P.180 Hand Dryer
- P.181 Air Curtain
- P.182 Ceiling Fan
- P.184 Orbital Fan
- P.185 Wall Fan

Ceiling Mount Type Ventilation Fan

Applicable Model:

24JRB / 24JAB / 17CUH / 24CUH / 24CDH / 24CHH / 24CXH / 27CHH / 32CDH
24CMUA/ 24CMHA/ 27CMHA/ 38CDG/ 38CDG 05/ 38CHG

1A Installation with anchor bolts

1. Secure 1 set of suspension bracket (optional accessory) with screws.

The screw length should not exceed 8mm.

*2 sets of accessories are required for 32CDH and 32CHH

Adjustable range

23mm

Adjustable range

25mm

Adjustable range

2. Mount the fan body enclosure on the anchor bolts (M8-M10, not supplied).

Model No.	A	B	C
17CUH	206	89	103
24CUH / 24CDH / 24CHH / 24CXH	266	131	112
24JRB / 24JAB	286	130	97
27CHH	296	160	158.5
32CDH	346	200	158.5
24CMUA/24CMHA	286	131	139
27CMHA	290	160	173
38CDG/38CDG05/38CHG	440	260	130

Unit : mm

1B Installation with wooden joist

1. First remove the hexagon screw attaching the adapter assembly to the fan body.

2. Build a wooden frame horizontally from the keel. Note that the distance between the top of the fan body and the ceiling should be at least 20mm.

*Ceiling joist must be subjected to static load more than 5 times of the product weight.

Model No.	F	B
17CUH	177	25-30
24CUH / 24CDH / 24CHH / 24CXH / 24CMUA/24CMHA/ 27CMHA	240	25-30
24JRB / 24JAB	240	30-40
27CHH	270	25-30
32CDH	320	25-30
38CDG/38CDG05/38CHG	380	30

Unit : mm

3. Attach the adapter assembly to the wooden frame as shown in the figure.

4. Insert the fan body in the wooden frame and connect it to the adapter assembly.

5. Firmly secure the fan body with four tapping screws and a hexagon screw.

Ceiling Mount Type Ventilation Fan

2 Power Cord Connection

1. Connect the power cord to the power supply line according to the wiring diagram and the local electrical wiring rules of fixed wiring.

Make sure all connections are fastened firmly after wiring is finished.

For 24JAB

For 27CHH/32CDH

For 17CUH/24CUH/24CDH/24CHH/24CXH/24JRB/24CMUA/24CMHA/27CMHA

For 38CDG/38CDG 05/38CHG

3 Duct Connection and Ceiling Plate Installation

1. Insert the duct into the adapter assembly, and tighten it with adhesive tape (not supplied). (Suspend the duct from the ceiling to prevent any external force onto the fan body.)

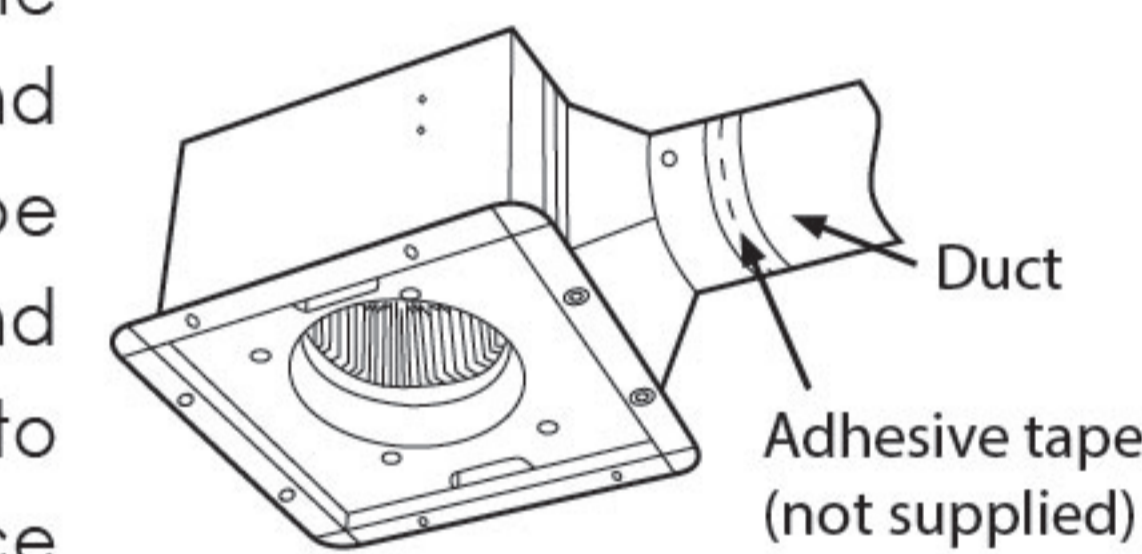

Slope the duct downward and guide it through the wall to the outside. Be sure to prevent rainwater from falling in the duct from its outlet. (The minimum size of the hole opening on the wall is: Ø116mm for 17/24 model, Ø168mm for 27/32/38 model)

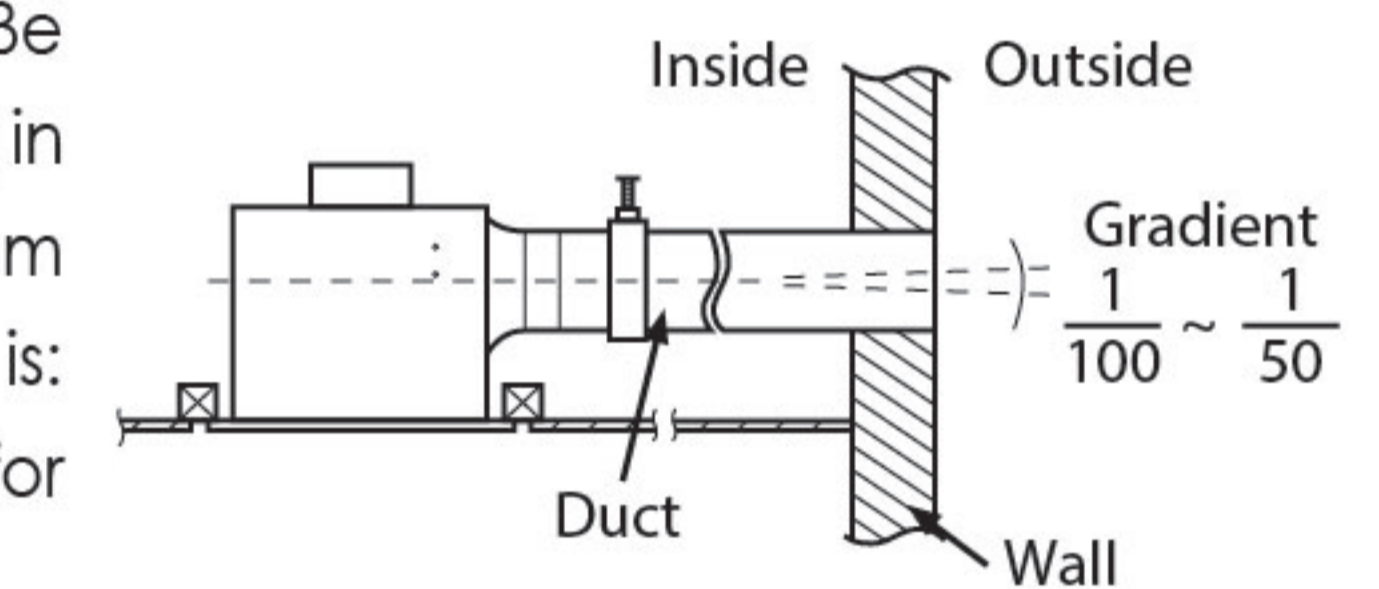

2. Install the ceiling plate. Note that the gap between the flange and the ceiling plate should be 2 to 5 mm.

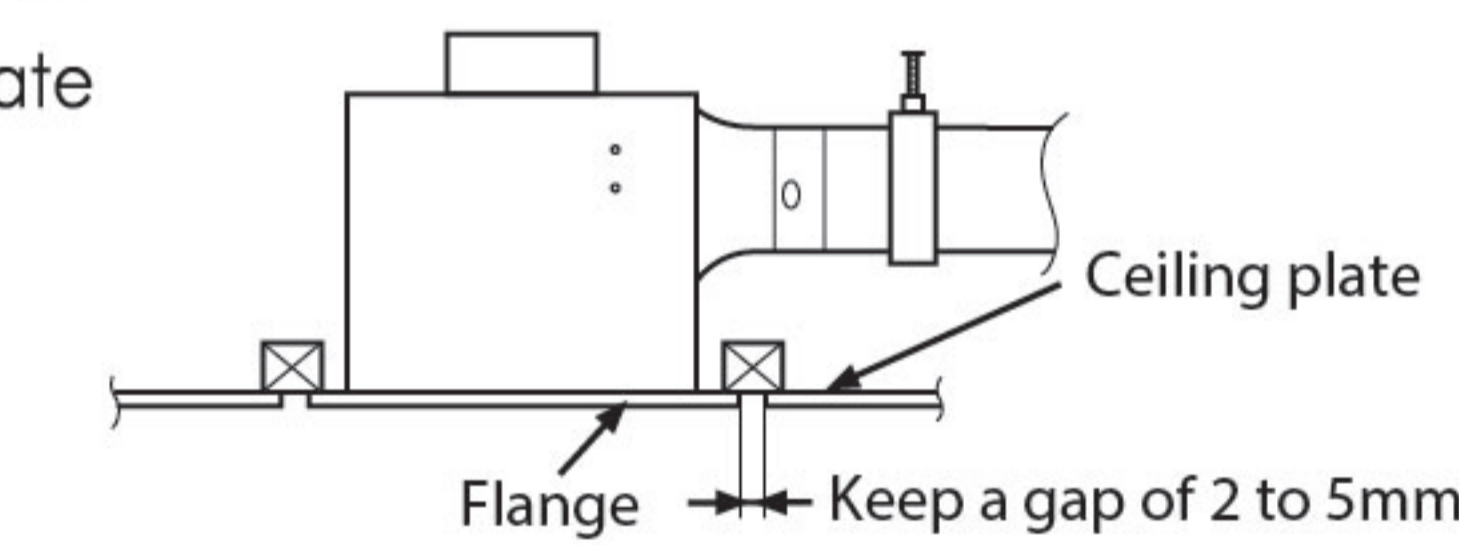

3. Install the pipe hood or vent cap (optional accessories) on the outer wall.

Model No.	Pipe Hood	Vent Cap
24JRB / 24JAB / 17CUH / 24CUH / 24CDH / 24CHH / 24CXH	MCX100K	VCX100K
27CHH / 32CDH / 38CDG / 38CDG 05 / 38CHG	MCX150K	VCX150K

4 Louver Installation

1. For 24JRB only
Check the sensor lead wire is fixed in the wire hook. Keep the wire away from the air intake and fan blade.

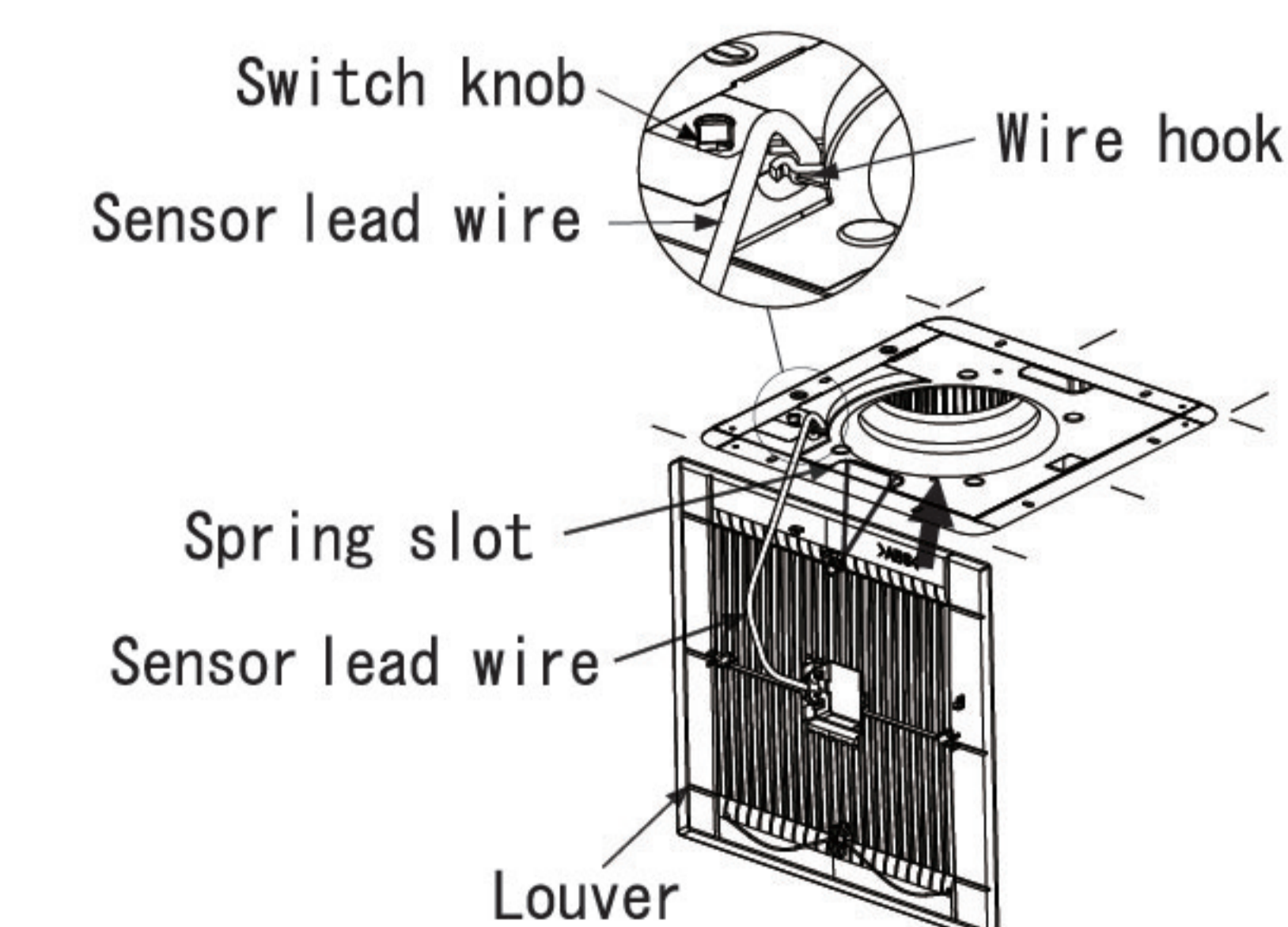

2. Insert the mounting spring into the slots and mount the louver to the fan body. (Please wear gloves during installation.)

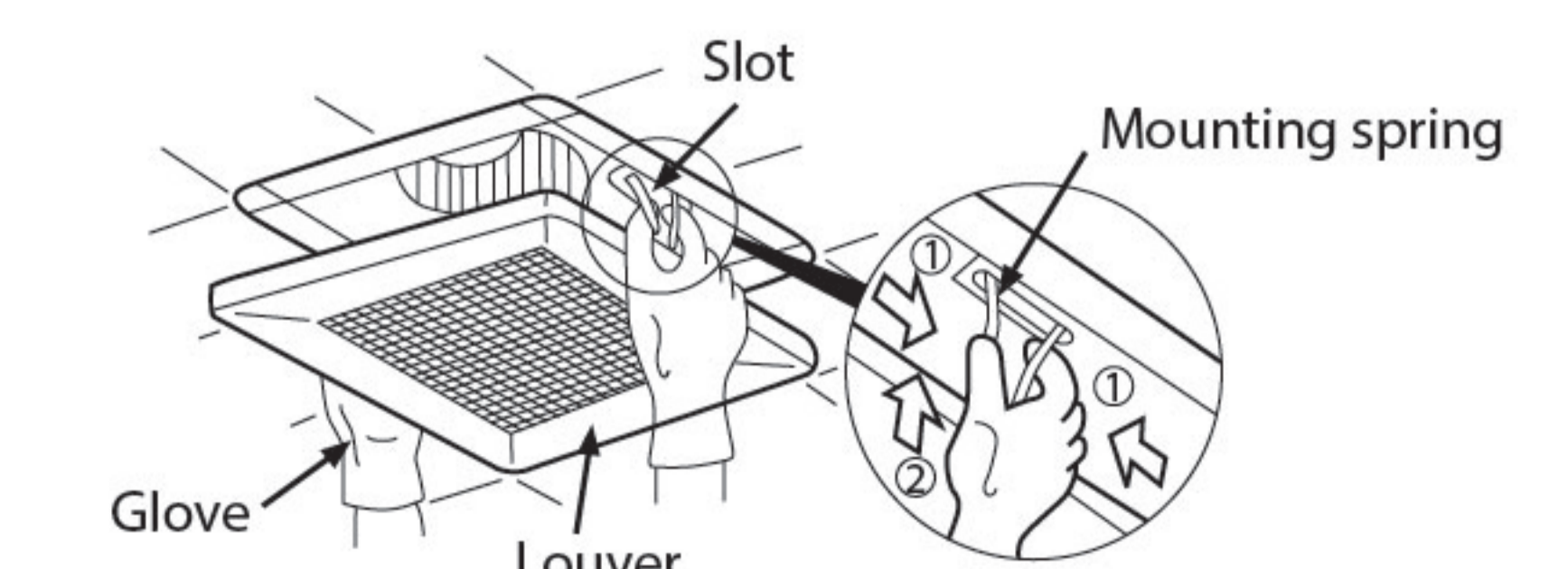

Wall Mount Type Ventilation Fan

Applicable Model:
AU model / AL model

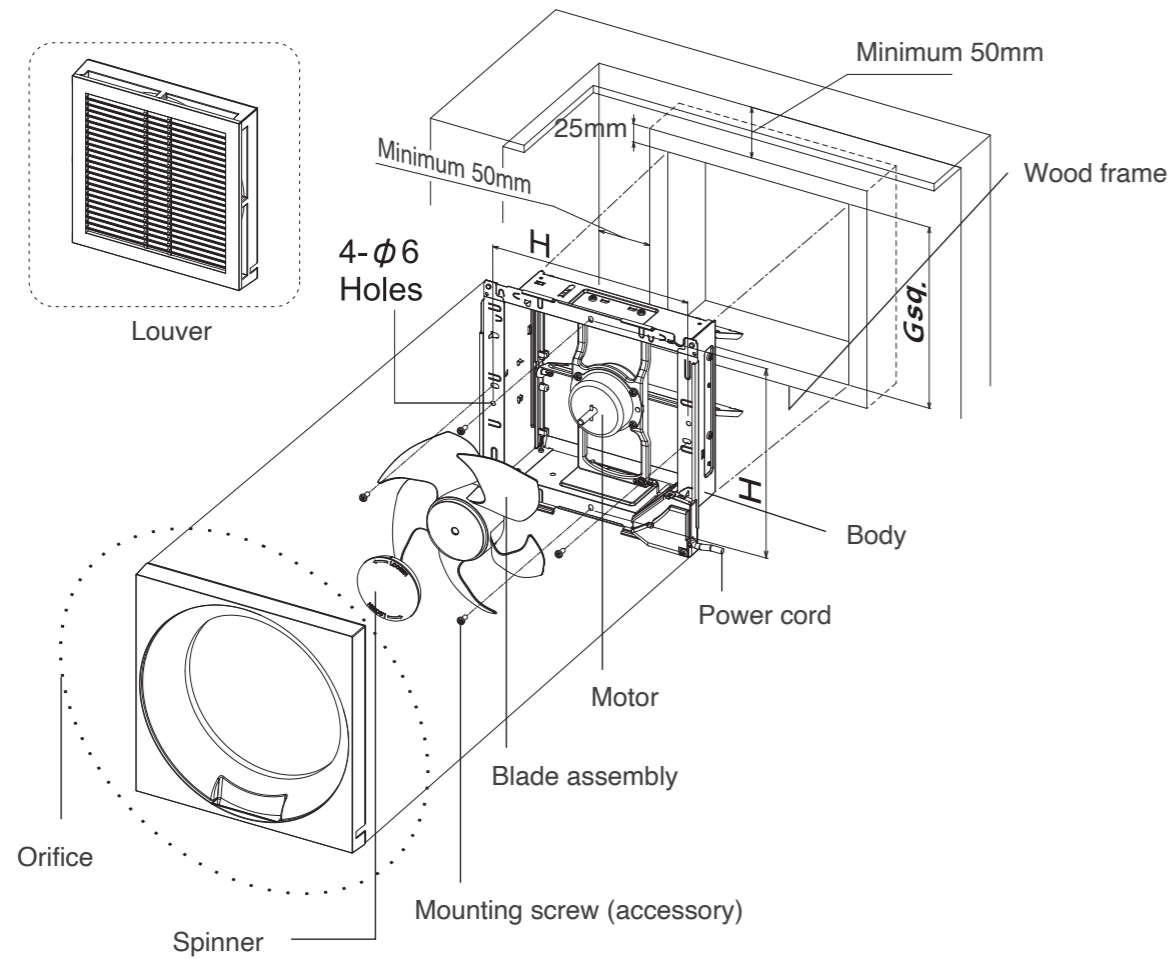

- Connect the power cord to the power supply line according to the wiring diagram and the local electrical wiring rules of fixed wiring.
- Make sure all connections are fastened firmly after wiring is finished.
- It is required to use terminal (not supplied) that complies IEC 60998.
- The all connections should be accommodated in a suitable compartment.

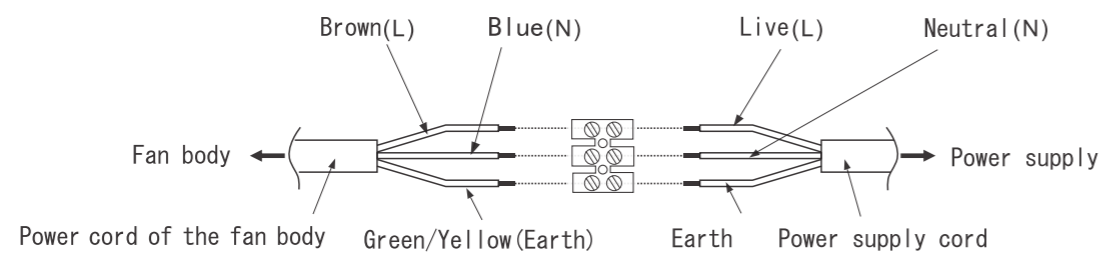

Wall Mount Type Ventilation Fan

Applicable Model:
10EGKB/15EGKB

1. Make appropriate hole in the wall for ducting.

Position of hole. Bathroom side

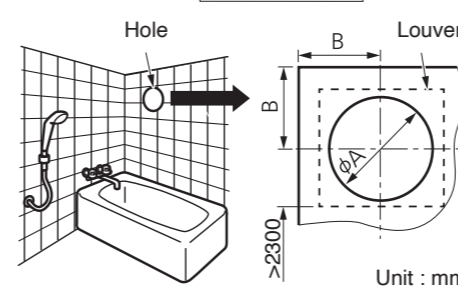

Model	φA	B	Wall thickness
10EGKB	130~140	>125	100~150
15EGKB	175~185	>150	

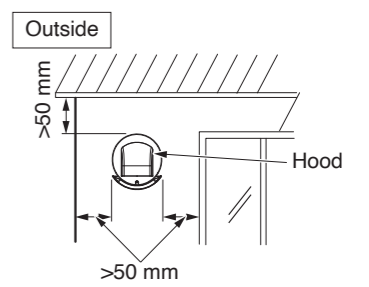
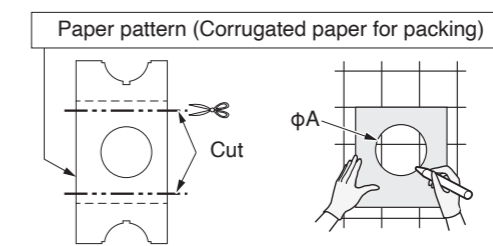

Note : It is noted that the wall does not collapse when making hole.
Do not install on the bumpy or rotten wall.

2. Drill holes for plug bolt.

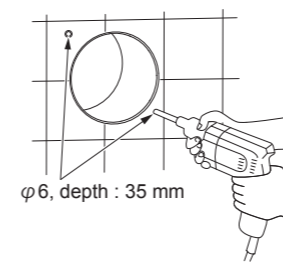

3. Insert the duct 1 to the wall using two screws and plug bolt.

Plug bolt (Accessories)

Note : Use accessory plug bolt and screw.

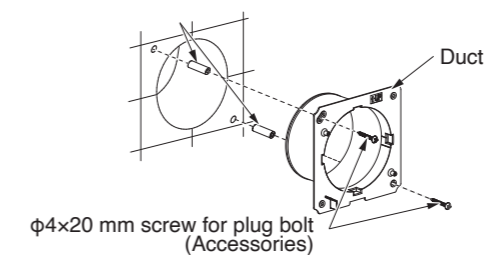

4. Insert the fan body to the duct 1.

Note : Make sure that use screw to fix the fan body. It may cause drop the fan body.

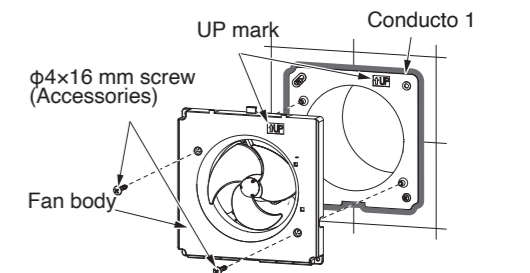

5. Install the louver

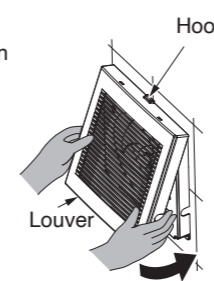
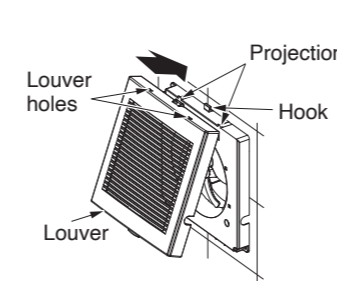

6. Hood installation (From outside wall)

① Put these notches together.

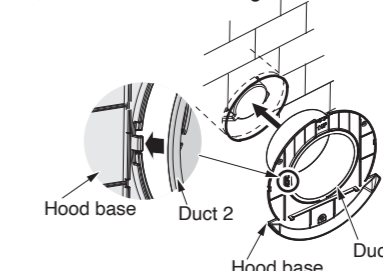

② Insert the duct 2 from outside wall.

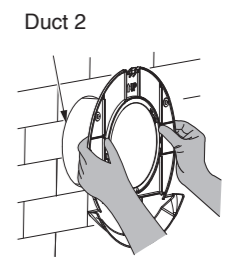

Note : Fit the duct 2 into the hood base when it come off.

7. Drill three holes for plug bolts.

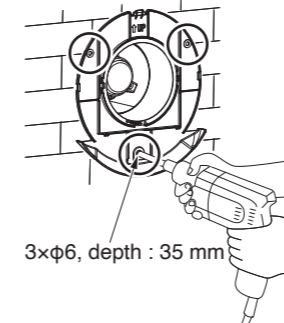

8. Hang and fix hood.

① Hang the hood into the hook. ② Fit the hood into the hood base.

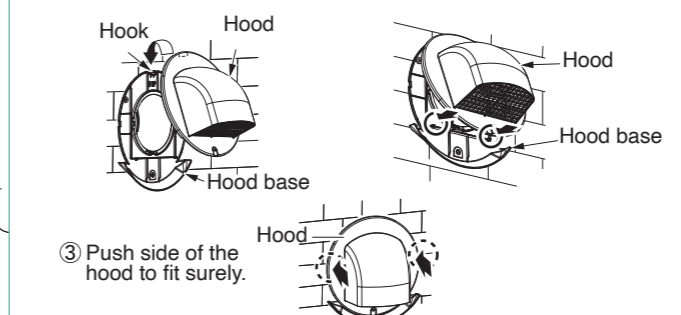

③ Push side of the hood to fit surely.

9. Insert the hood to the wall seal with caulking around the hood.

Note : Make sure that use accessory screw to fix the hood. It may cause drop the hood.

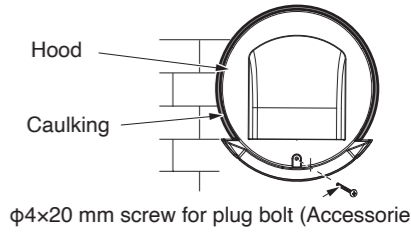

Window Mount Type Ventilation Fan

Applicable Model: 15WHCT/20WHCT

1. Make an installation hole on the window glass according to the dimensions shown in the table.
(Applicable to single-glass or double-glass, and the single block thickness of double-glass must be not less than 3mm.)

Model No.	A	B	C
15WHCT	186-188	390 Min.	100 Min.
20WHCT	247-250	450 Min.	100 Min.

Unit : mm

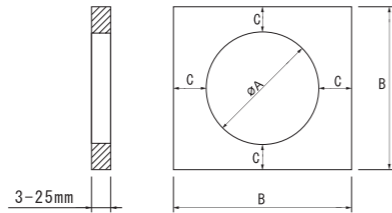

2. Remove the screw of louver and retain it, then pull the louver out of the lower-right corner.

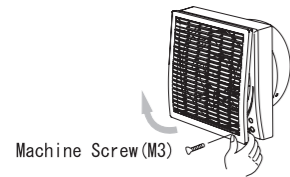

Louver can be pulled out only from the lower-right corner or it may be damaged.



3. Before installation, please ensure every installation plate is at the position as shown below.

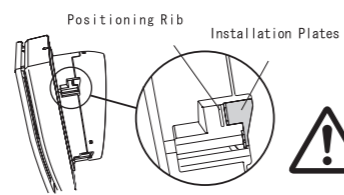

As shown in the diagram, the installation plates must be positioned in the slot between the frame and the hood. Its front edge should not exceed the positioning rib, or installation may fail.

4. Keep the "UP" mark on the orifice on the top position. Insert the ventilation fan body into the installation hole completely. Be sure to keep the back of the body closed to the glass evenly, then twist each installation screw clockwise until the installation plates slightly compress the glass.

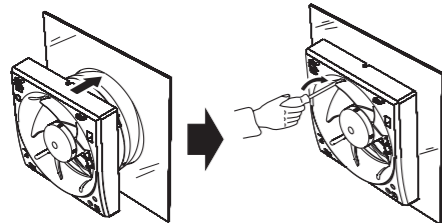

Please do not use the electric screwdriver which may damage the glass.

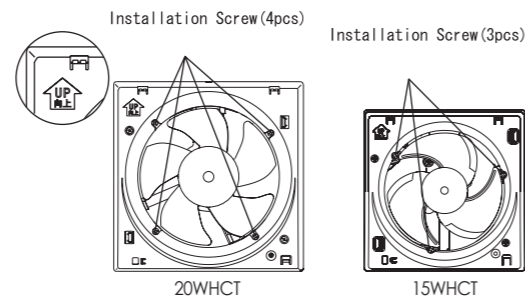

5. Rotate the body to adjust its horizontal and vertical direction. Then tighten each installation screw completely.

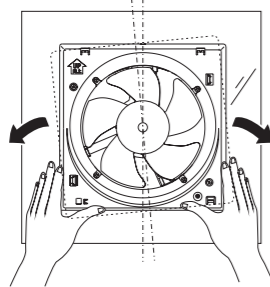

To ensure the installation strength, please make sure the tighten torque must be in the range of 90cN-m to 180cN-m. If the tighten torque is not large enough, it may result in rain water ingress through the gap; if the tighten torque is too large, it may damage the glass.

6. Hang the louver on the hook of orifice, rotate downward and insert it into the orifice. Fix the louver with the screw which was removed at installation step 2.

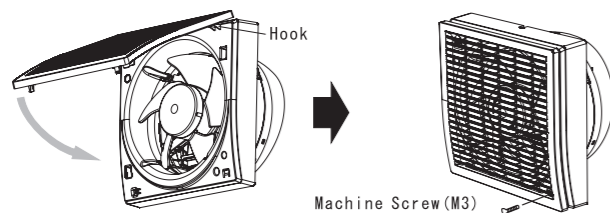

Must use the above specified screw to fix. Otherwise it may damage the product or lead to installation failure.



Window Mount Type Ventilation Fan

Applicable Model: 15WUD/20WUD/15WAA/20WAA

1. Make an installation hole on the window glass.

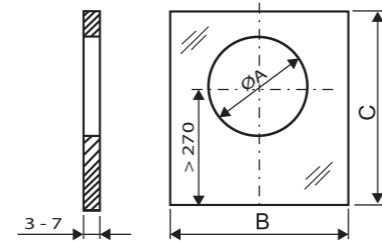

Unit : mm

Model No.	A	B	C
15WUD	186-188	≥250	≥400
20WUD	247-250	≥300	≥420
15WAA	186-188	≥250	≥250
20WAA	247-250	≥300	≥300

2. Set the plastic gasket on the hole that the seam is at upper half (either left or right side). Seal the gap between the glass and gasket with silicon sealant to ensure airtightness.

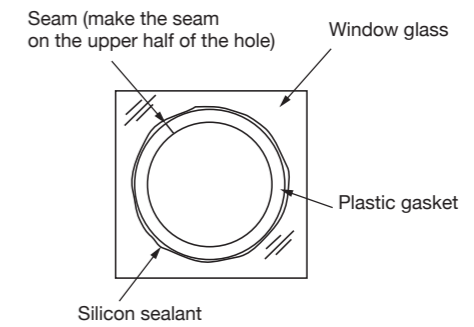

3. Loosen the orifice screws (2 pcs) and remove the orifice.

15WUD / 20WUD

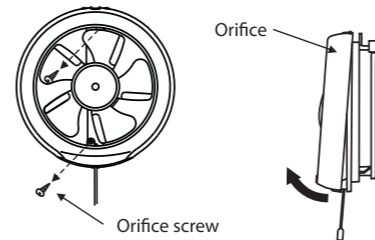

15WAA

20WAA

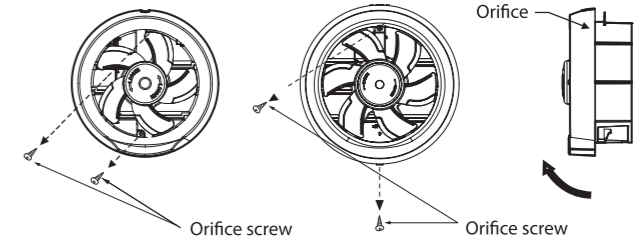

4. While installing the fan, align the fan to top of the hole of window glass and push the bottom of the fan into the hole. Then push the fan downward and tighten the safety screw afterward.

15WUD / 20WUD

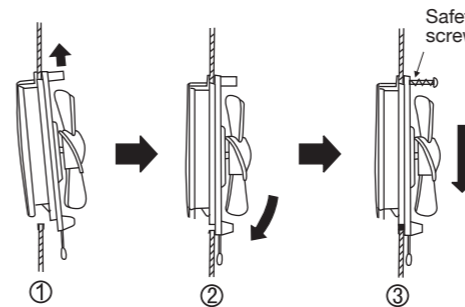

15WAA / 20WAA

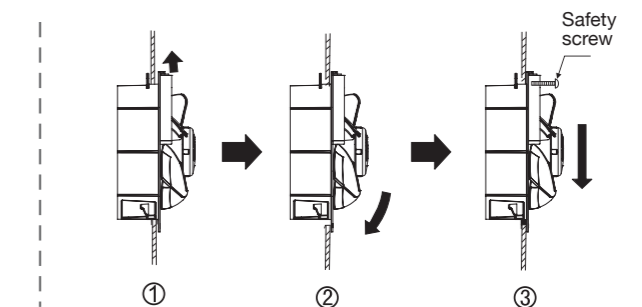

5. Set the orifice and fix with the orifice screws (2 pcs)

15WUD / 20WUD

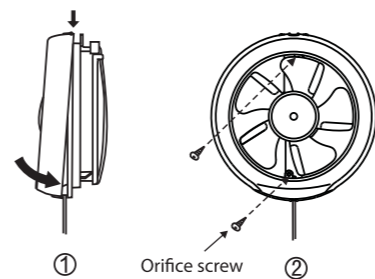

15WAA / 20WAA

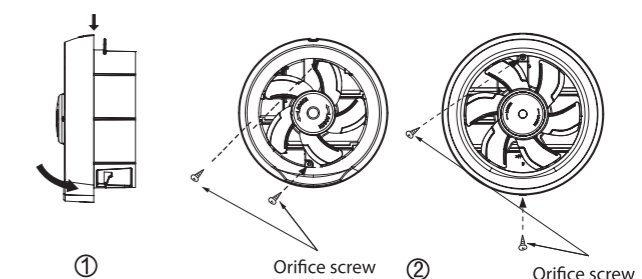

Industrial Type Ventilation Fan

Applicable Model:
High Pressure Series

Installation on concrete wall

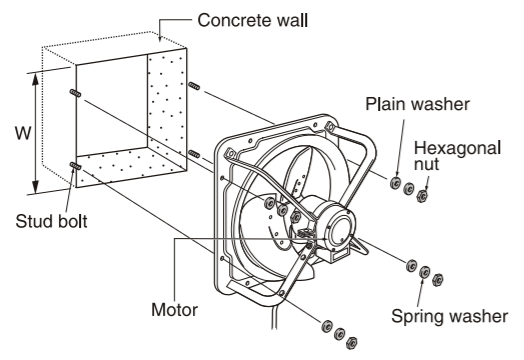

Installation on wooden frame

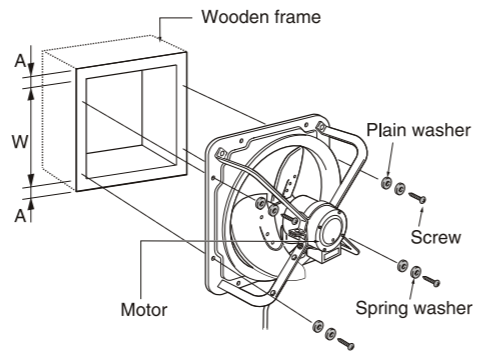

Setting of Reverse Airflow

- For 25GSE, 30GSE and 35GSE
- 1) Loosen the blade setscrew to remove the blade
 - 2) Set the wiring according to wiring diagrams in operation instruction
 - 3) Mount the blade in reverse position and fix with the blade set screw

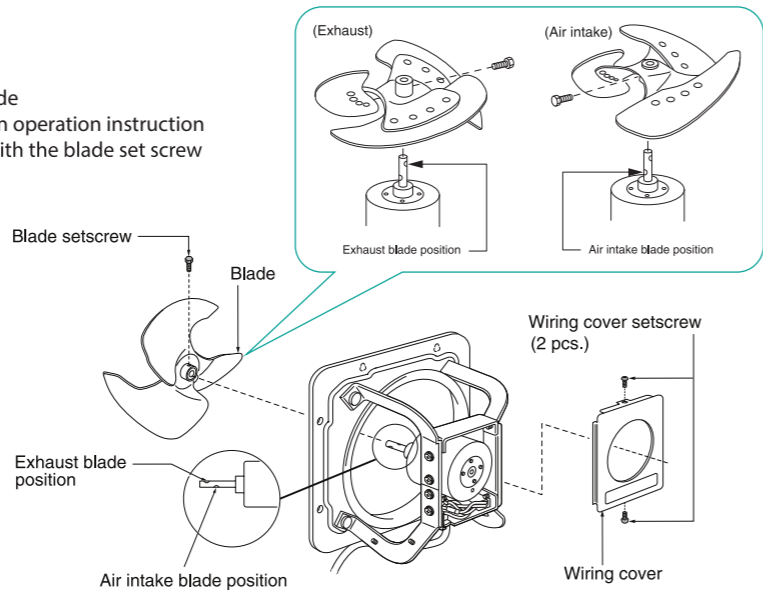

- For 40GSE, 45GSC, 50GSC, 60GSC, 45GTC, 50GTC & 60GTC
- 1) Loosen the blade setscrew ^{(*)1} or snap pin / hexagonal nut ^{(*)2} to remove the blade
 - 2) Set the wiring according to wiring diagrams in operation instruction
 - 3) Mount the blade in reverse position and fix with the blade setscrew ^{(*)1} or snap pin / hexagonal nut ^{(*)2}

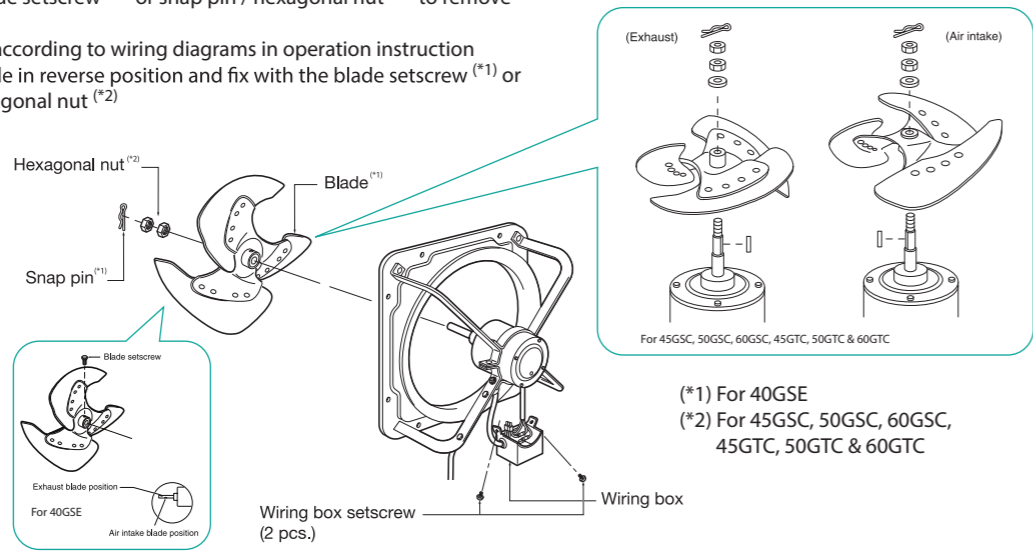

* Air volume of reverse airflow (intake) would vary subject to different models

Low Noise Type Cabinet Fan (In-line Fan)

Applicable Model:
12NSB/15NSB/18NSB/18NFB/20NSB/23NLB/25NSB/25NFB

To hang the fan be sure to attach firmly with hanger bolts, washers and nuts. (Which should be M8-M10 and be supplied by the customer)

Vibration cushion rubber set (supplied by the customer) can be used if in special condition for vibration requirement and it must support the weight of the product.

The structure of the ceiling and the suspending set for hanging the product must support more than 5 times weight of the product.

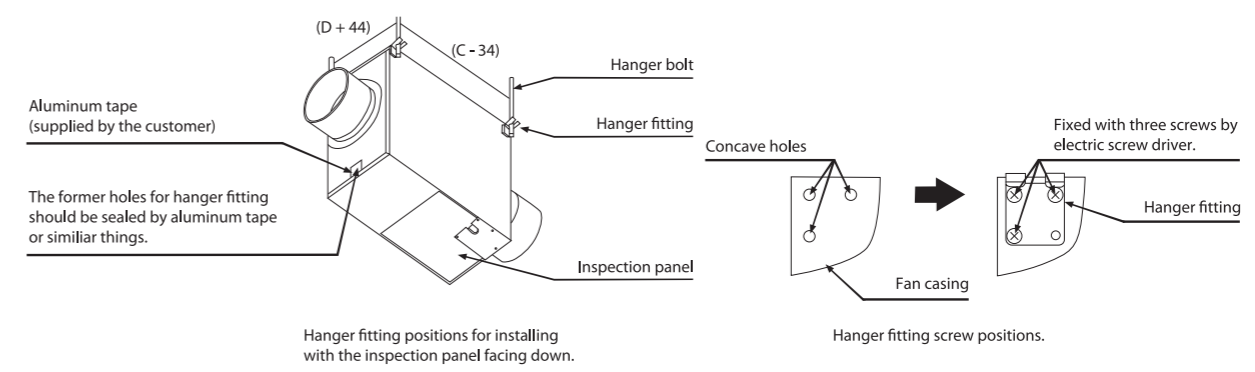
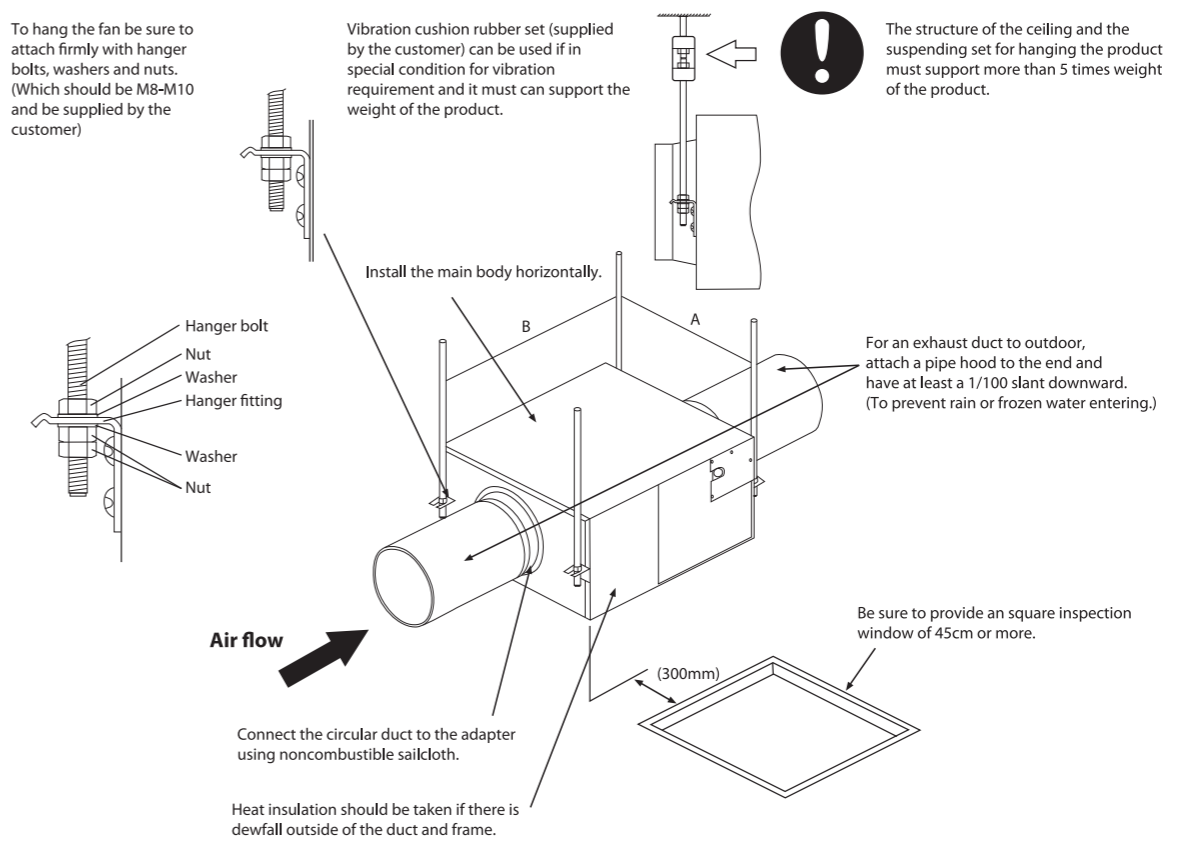

Note: To install the fan with the inspection panel facing down, remove the attached four hanger fittings and re-attach them in the holes on the top and bottom surfaces (Use the screws you just removed). The former holes for installing the hanger fitting need be sealed.

Model No.	A	B	C	D
12NSB	250	335	291	184
15NSB	250	346	302	206
18NSB	276	382	338	232
18NFB	336	441	397	254
20NSB	376	485	441	272
23NLB	424	513	469	298
25NSB	450	549	505	334
25NFB	450	549	505	334

Unit : mm

Low Noise Type Cabinet Fan (In-line Fan)

Applicable Model:
25SWC/25SMC

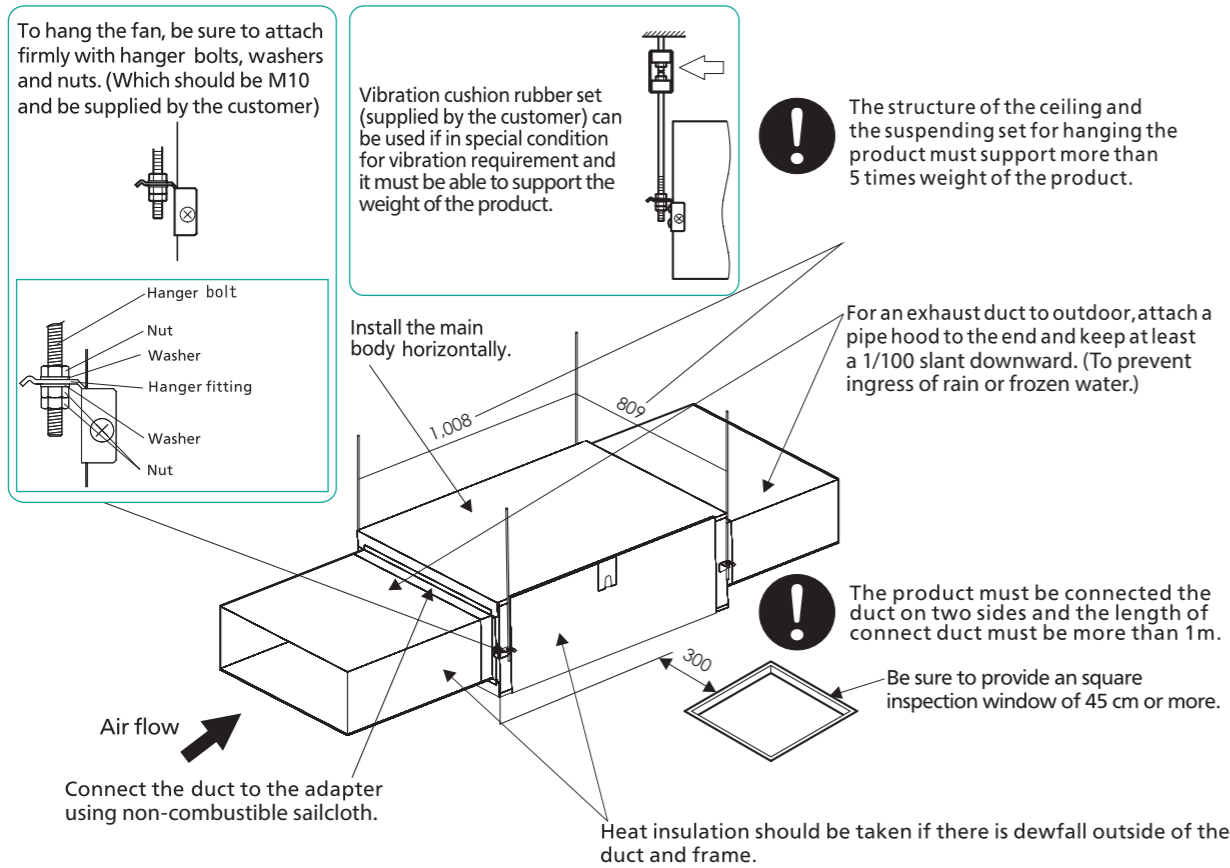

Wiring Connection

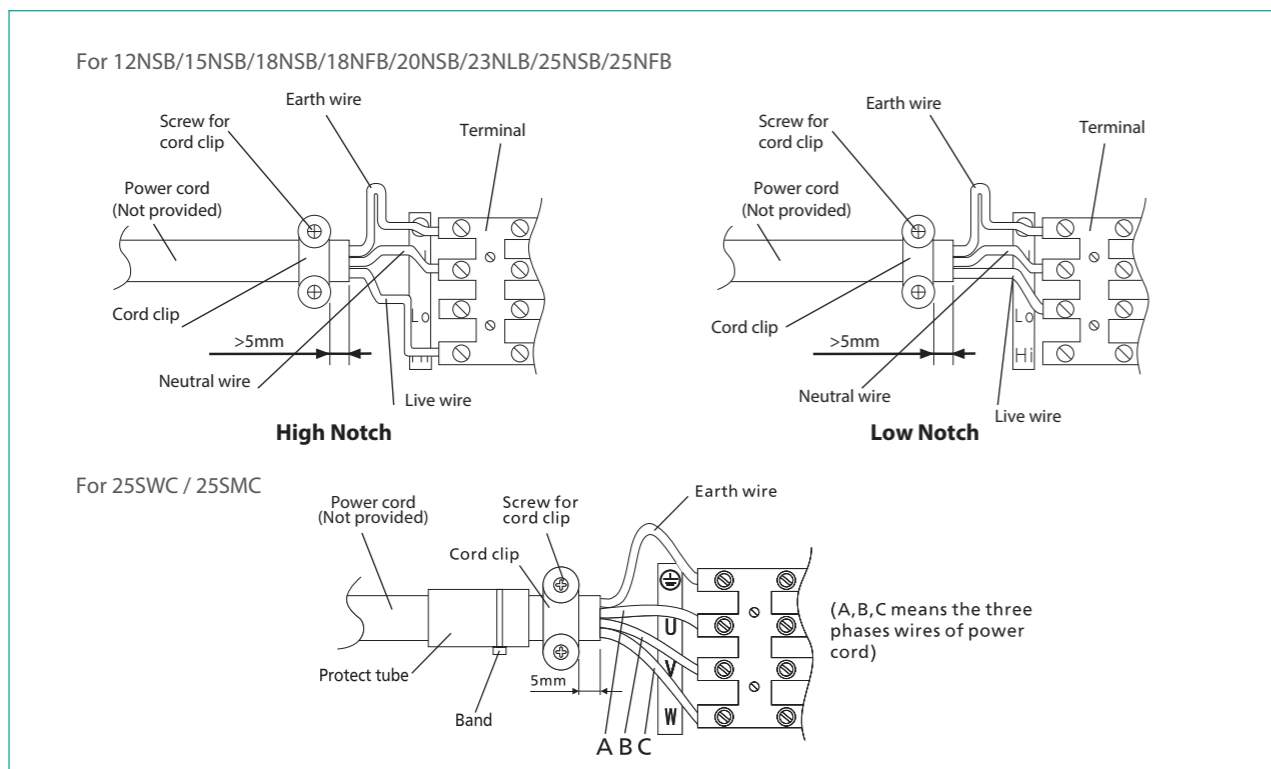

Mini Sirocco Fan

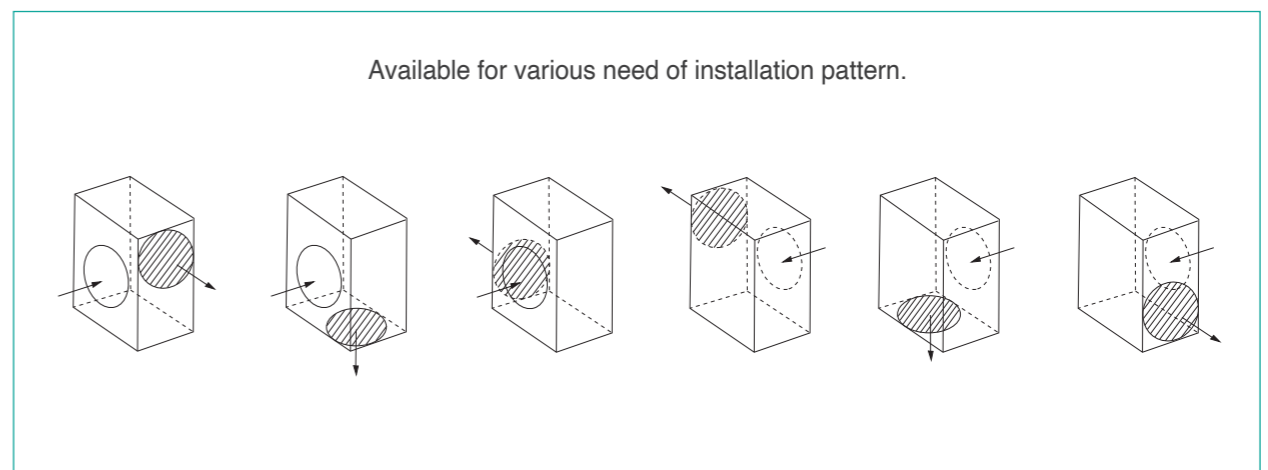
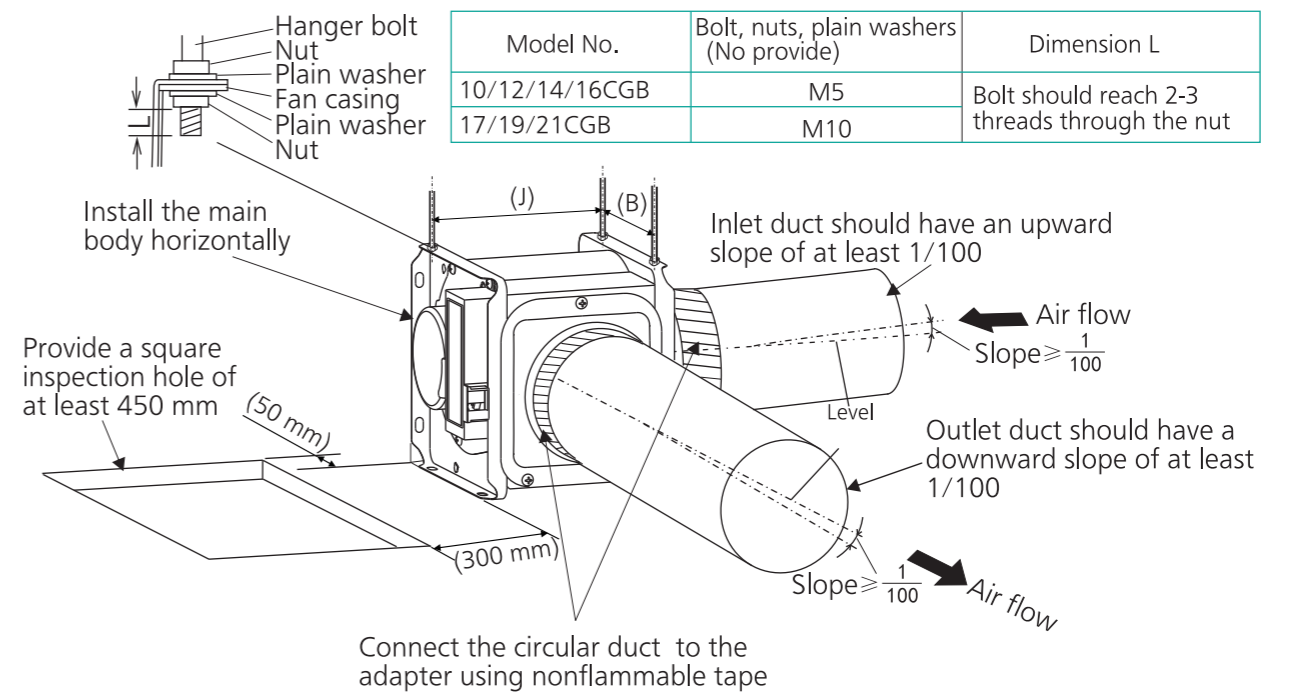
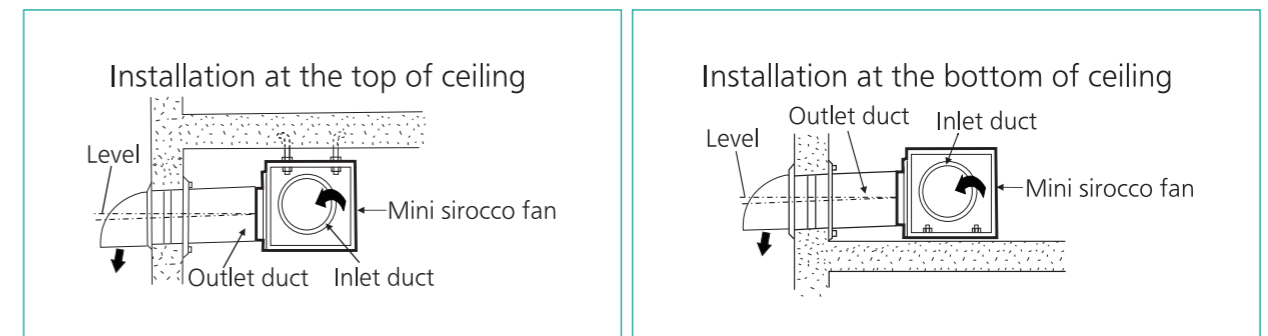

Energy Recovery Ventilator

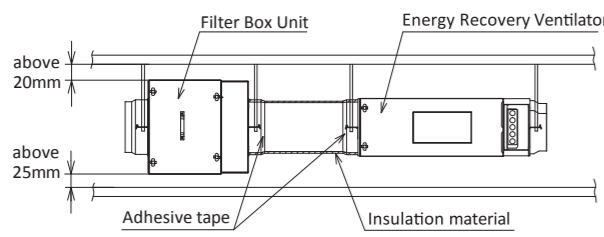
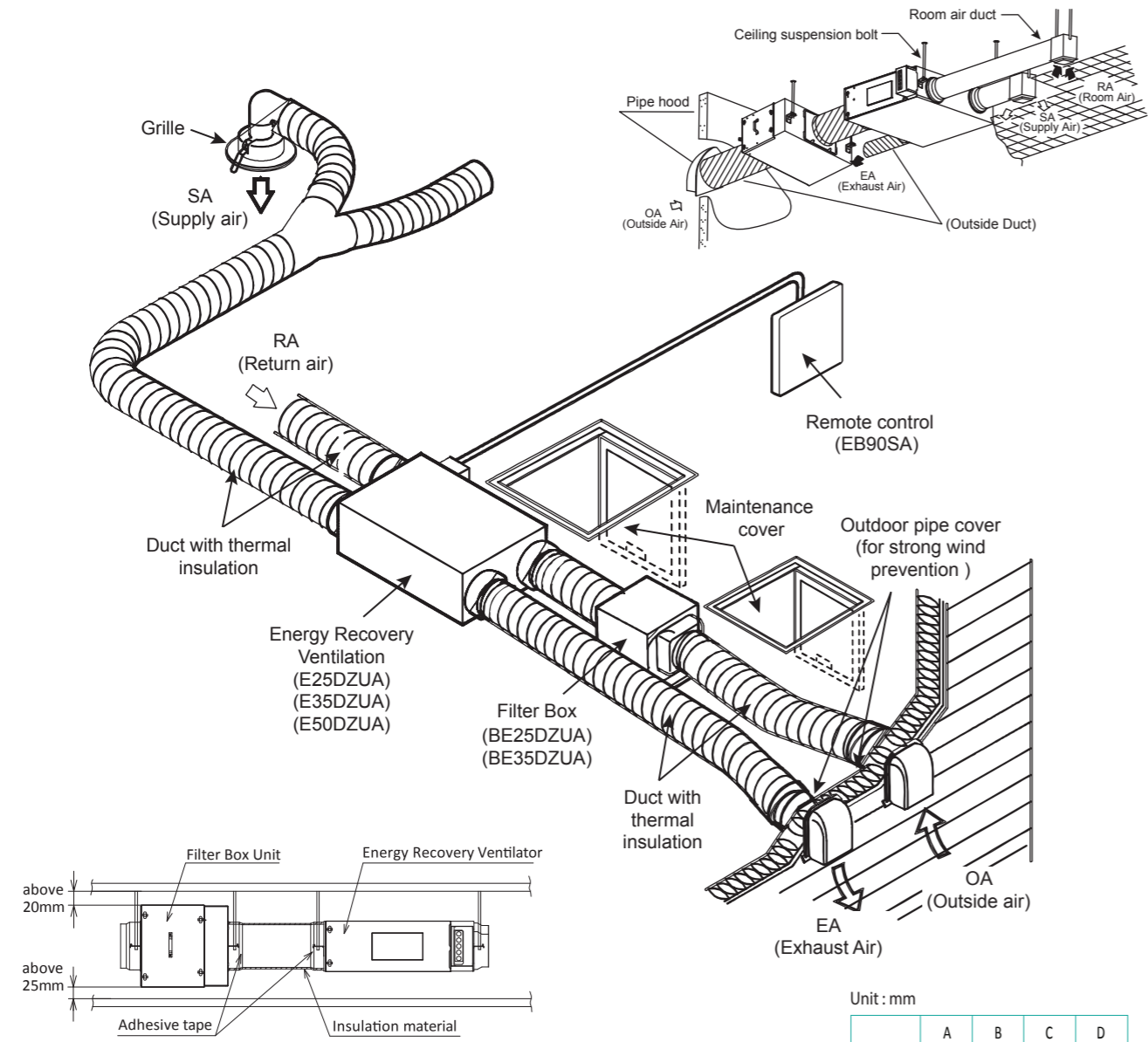

Unit : mm

	A	B	C	D
E25DZUA	695	693	853	649
E35DZUA	723	858	865	654
E50DZUA	723	1026	865	655

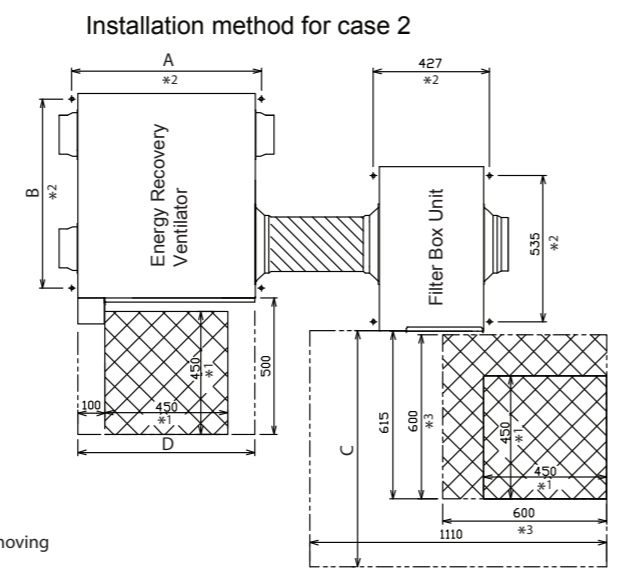
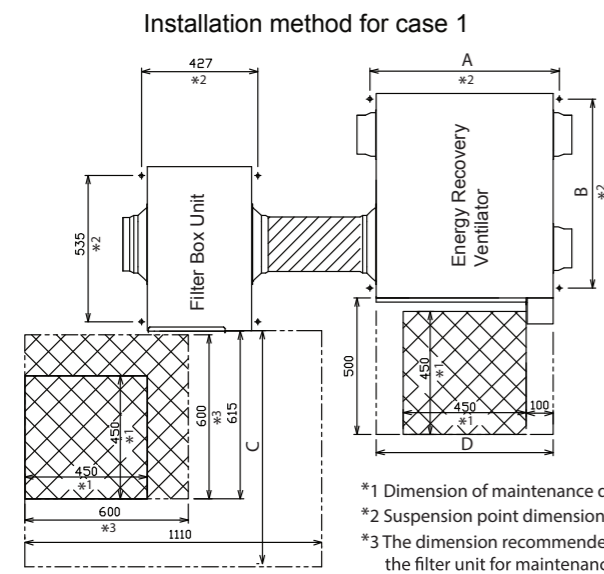

*1 Dimension of maintenance door
 *2 Suspension point dimension
 *3 The dimension recommended to removing the filter unit for maintenance

Thermo Ventilator

Applicable Model:
30BUC

1. Open the cord cover and set the wiring

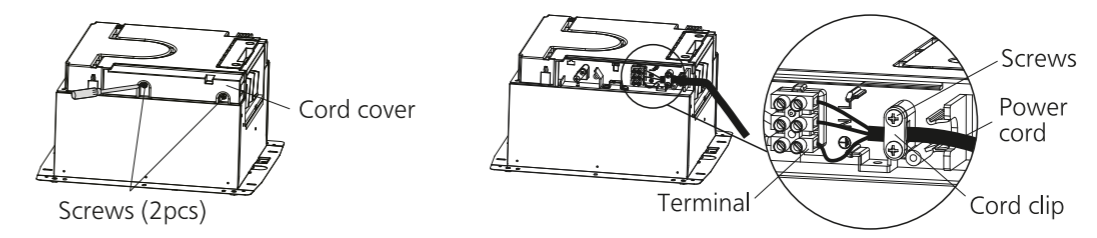

2. Install fan body in the ceiling

2.1 Installation with wooden joist

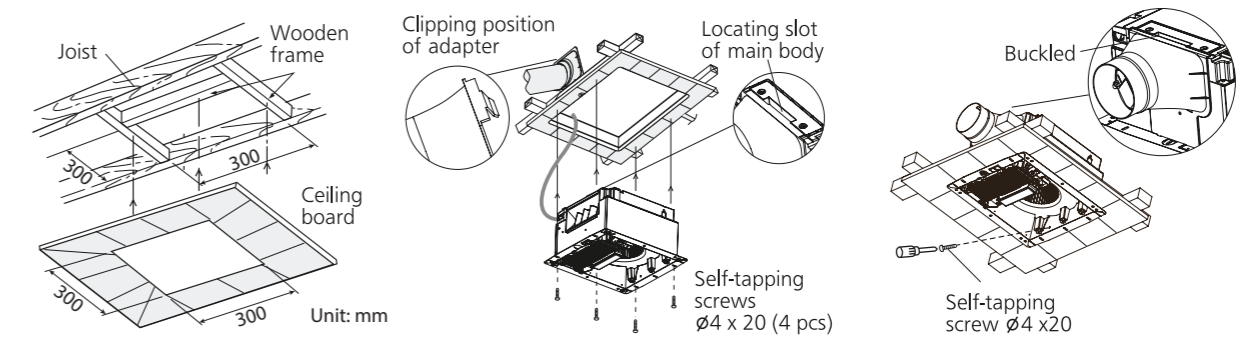

2.2 Installation with anchor bolts

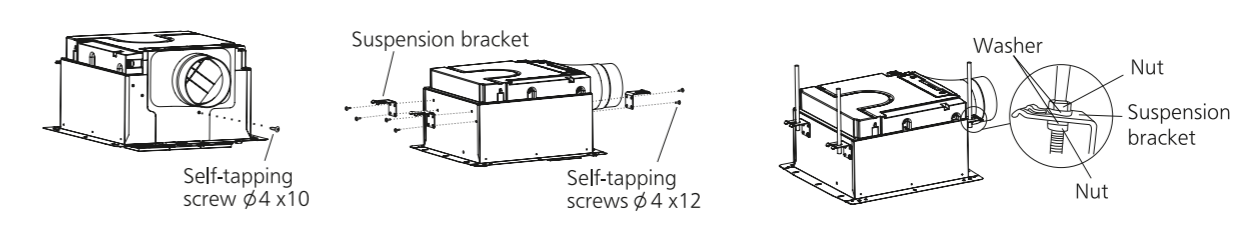

3. Set and tighten louver assembly with screws

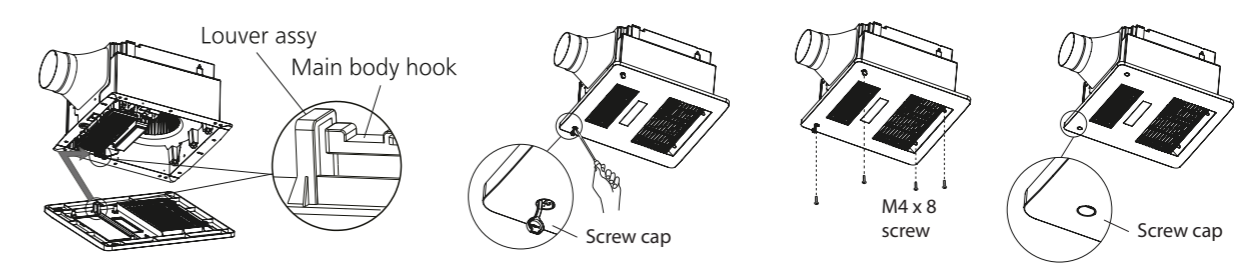

4. Set filter into the louver assembly

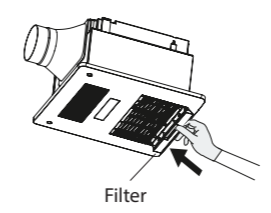

5. Connect duct pipe

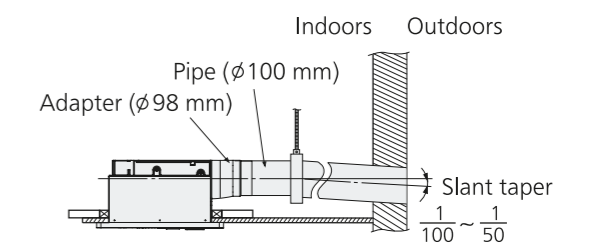

Range Hood

Applicable Model:
90HQUA

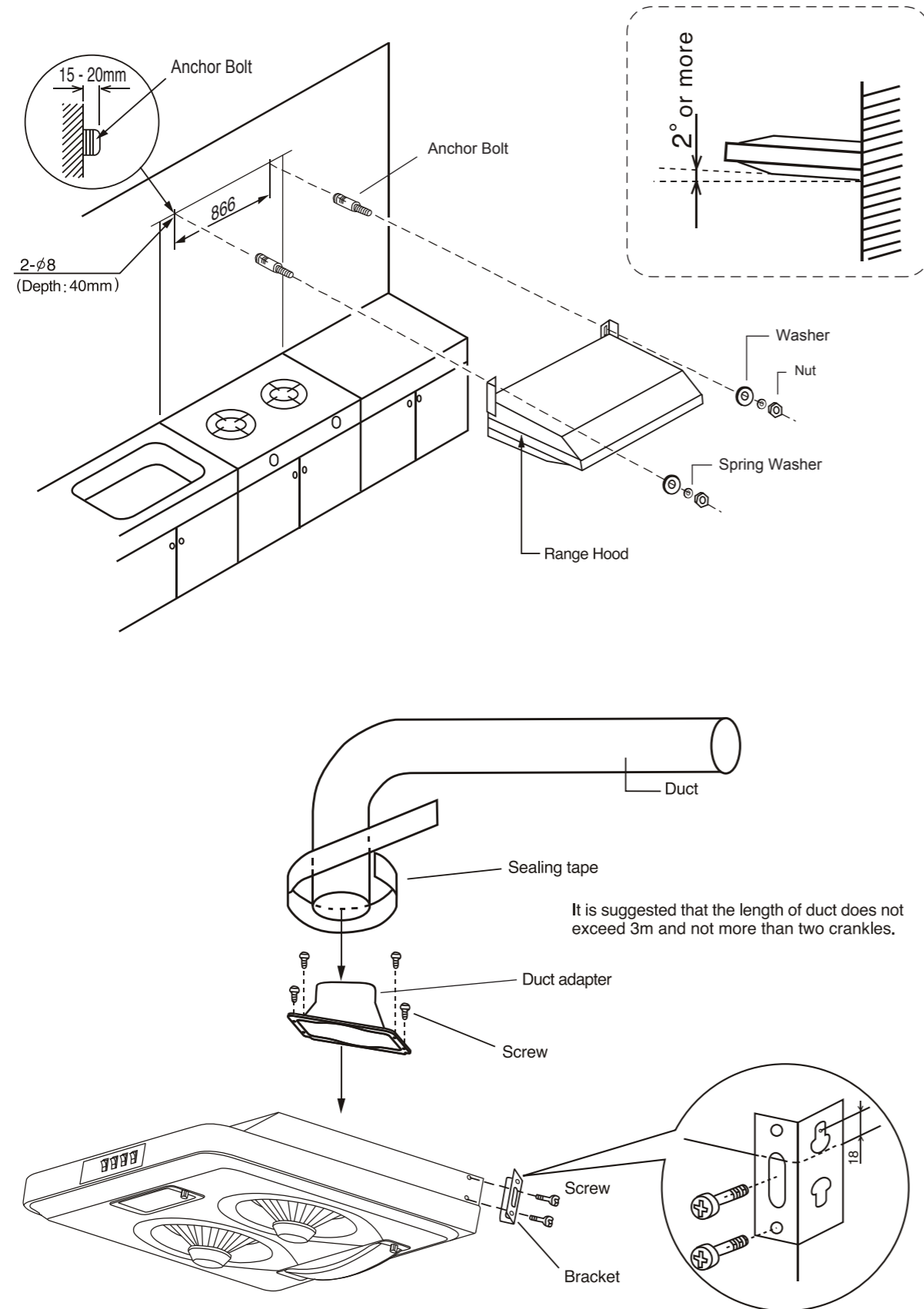

Hand Dryer

Applicable Model:
T09AC and T09BC

1. Install fixation board on the wall

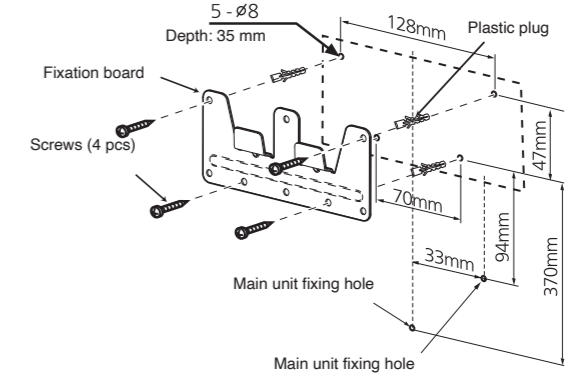
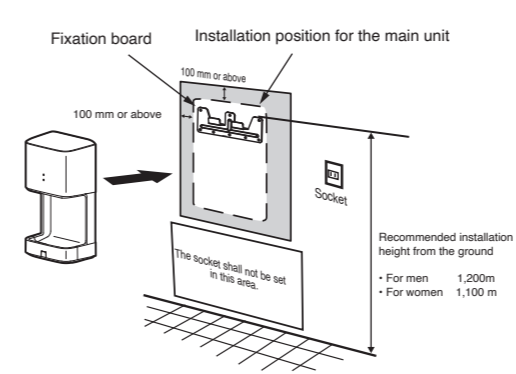

2. Adjust length and lead out direction of power cord

I. Remove the fixing screws on the back baffle plate of the main unit

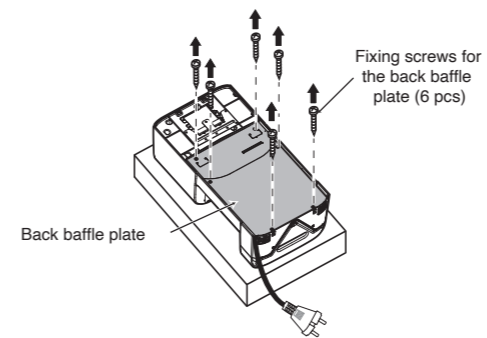

II. Adjust the length of power cord by winding according to below figure, and select the lead-out direction

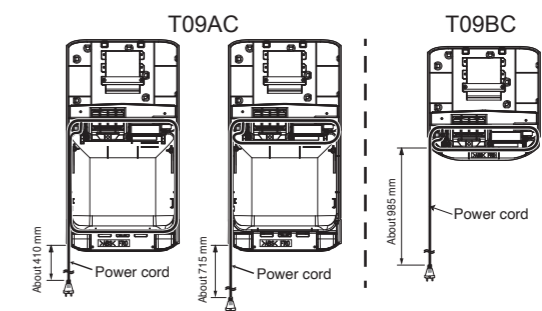

3. Set the main unit into the fixation board

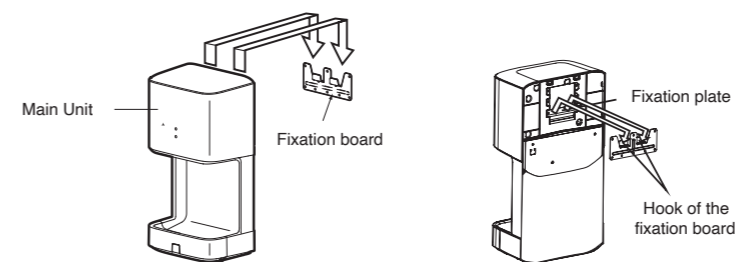

4. Fix the main unit with fixing screw

For T09AC

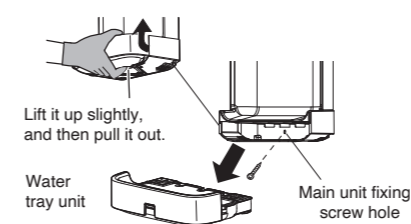

For T09BC

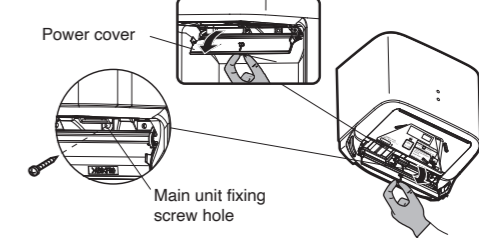

Air Curtain

Applicable Model:
Cross Flow Type

1. Install mounting plate on the wall

I. Remove the mounting plate from rear of the product

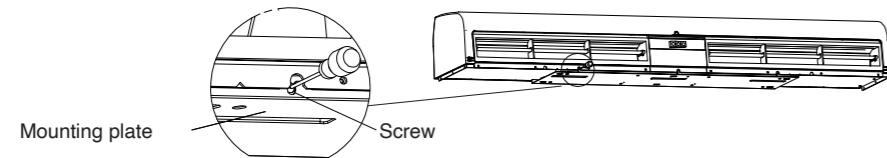

II. Set the bolts on the wall

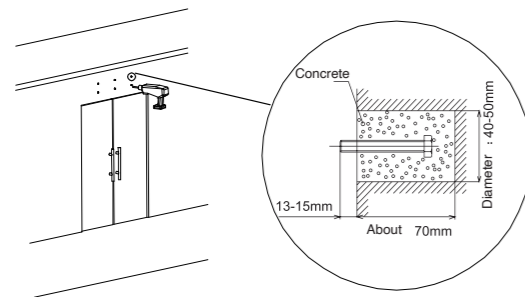

III. Fix the mounting plate with washers and nuts

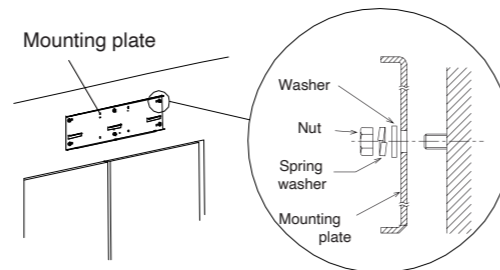

2. Wiring

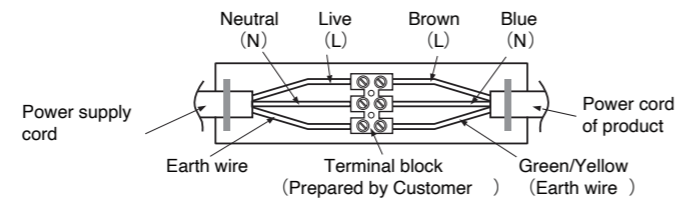
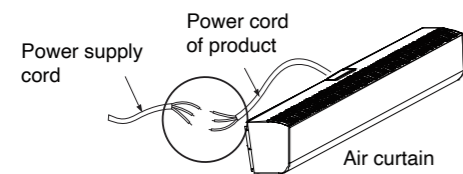

3. Install air curtain

I. Hook the air curtain on the mounting plate and tighten the screws (x3)

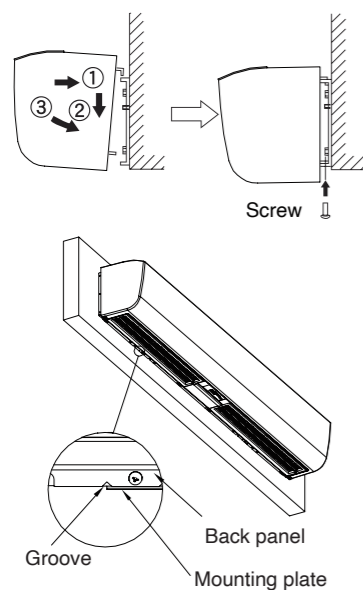

II. Fix the contact sensor (for Sensor Series only)

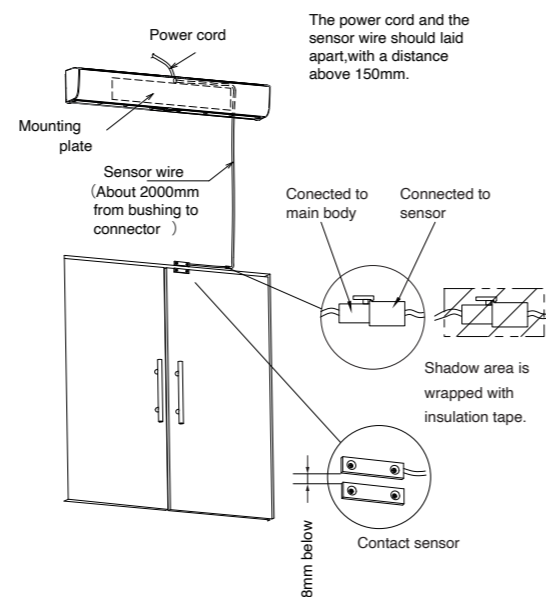

Ceiling Fan

Applicable Model:
Regulator Control Series

(1) Assemble Pipe to Motor Assembly

1. Pull power cord (from power supply) and insert into the Pipe hole.
2. Ensure the Shaft Cap is set on the Motor Shaft and tighten with the Stopping Screw. Fit the Pipe to the Shaft Cap that the Pipe hole and the Motor Shaft hole are aligned.

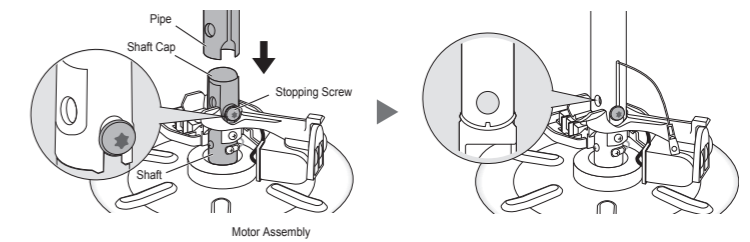
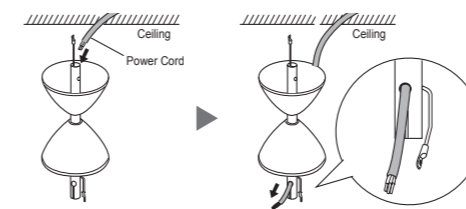

3. Fix the Pipe and Motor Assembly with a) Ellipse Bolt, b) P-R Washer, c) Spring Washer, d) Hexa Nut and e) Cotter Pin.

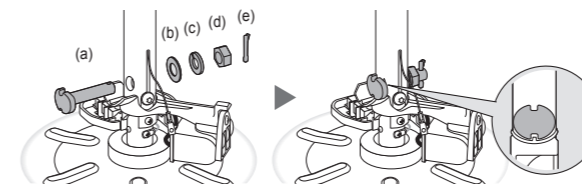

4. Bend the Cotter Pin.

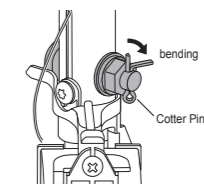

5. Fix Safety Wire to the Motor Shaft with Safety Wire Screw.

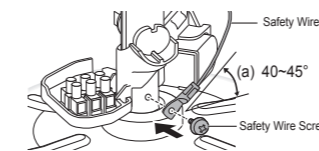

6. Connect the power cord to 3-pin Terminal.

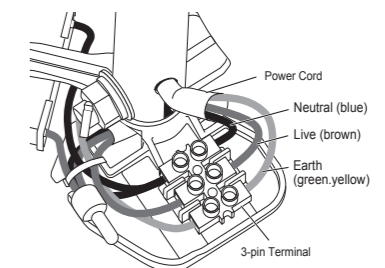

(2) Install Blade Assembly

1. Remove Blade Screws from Motor Assembly. Set the Blade towards the Cover Hook and ensure the Blade Safety Plate is in proper position.

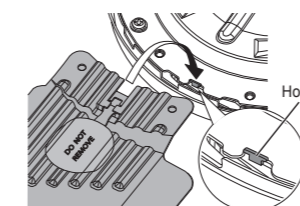

2. Tighten the Blade Screw firmly (2 screws per blade)

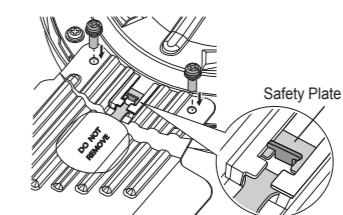

Ceiling Fan

(3) Install to the ceiling

1. Cross the C Hook of the Pulley Set to the Pipe and Place the Pulley on Ceiling Hook
2. Loop the Safety Wire to the ceiling hook and fix to the Pipe with the Safety Wire Screw

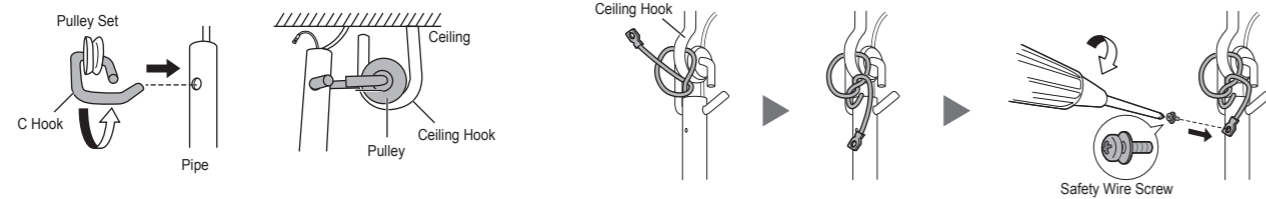

(4) Fix the Canopy

1. Adjust Upper Canopy position and fix to the Pipe with screw.
2. Pull down the Lower Canopy until it stop and fix to the Pipe with screw.



(5a) Install Speed Regulator (Slim Panel Regulator)

1. Insert the Live Wires (from supply source and Motor) into the 2 pin terminal of the regulator and tighten the terminal screw.
2. Set the Regulator to the wall regulator casing and fix with screws.



(5b) Install Speed Regulator (Box Regulator)

1. Insert the Live Wires through the hole of Regulator Base and fix the base with the screws.
2. Insert the Live Wire (from supply source and Motor) into the 2 pin terminal of the regulator and tighten the terminal screw
3. Set the Regulator cover by inserting the protruding parts of the Regulator Base into the holes of Regulator Cover and fix with the screw

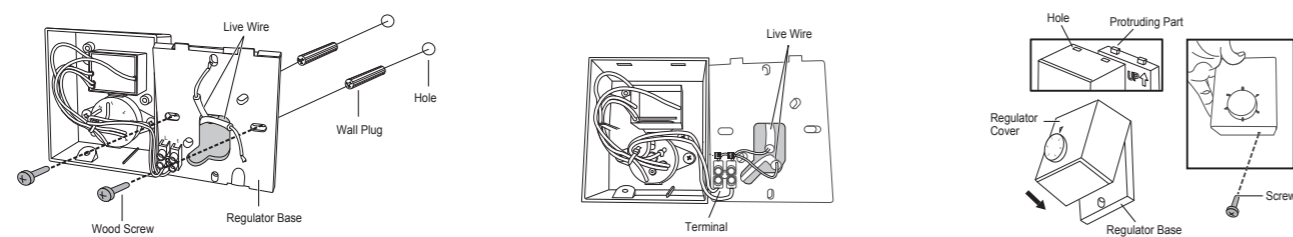

Orbital Fan

1. Install fan stand on the ceiling

I. Install mounting plate on the ceiling with the bolts (x2)

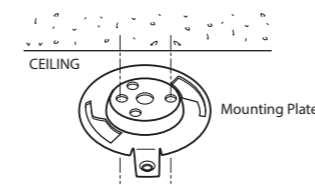

II. Loop the safety wire around left arm of the stand and clip as (A)

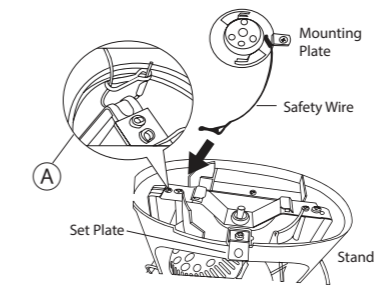

III. Set the stand to the mounting plate. Align the screw hole and tighten the set screw

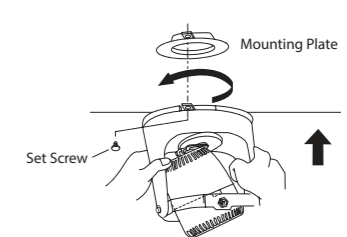

2. Assemble the fan

I. Set rear guard on the stand by aligning the projection part to the hole

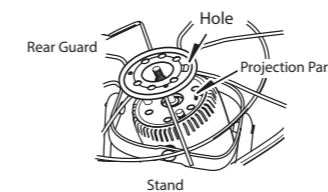

II. Fit rear guard on the stand with wing bolt (2 pcs)

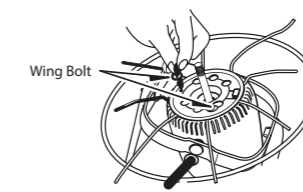

III. Insert blade boss to the shaft. Ensure the groove is correctly fit to the shaft pin

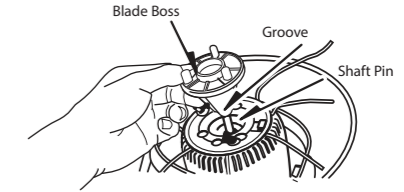

IV. Set the blade to the blade boss and align the projection part to the hole of blade

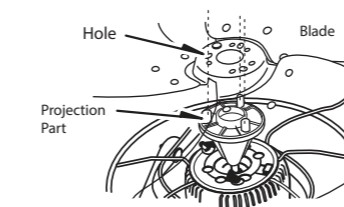

V. Tighten the spinner to fix the blade

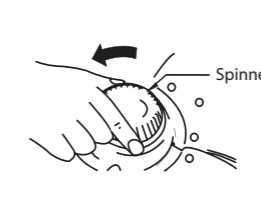

VI. Set front guard to the rear guard and clip.

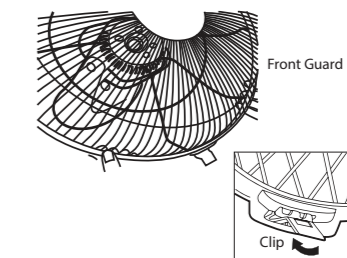

3. Install Regulator and Wiring

I. Open the regulator cover and mount the regulator base on the wall

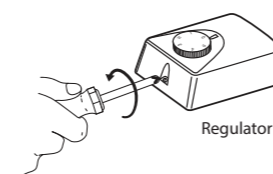

II. Set the wiring according to the wiring diagram and re-assemble the regulator cover

